



SEALED PELLET STOVE

# GIO' AIR 8 S1

Instructions in English

**MCZ**

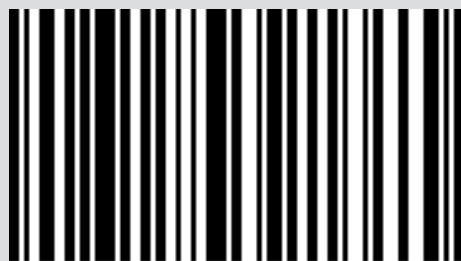

8901825002

## TABLE OF CONTENTS

TABLE OF CONTENTS .....	II
INTRODUCTION .....	1
1-WARNINGS AND WARRANTY CONDITIONS .....	2
2-INSTALLATION .....	11
3-DRAWINGS AND TECHNICAL FEATURES.....	19
4-INSTALLATION AND ASSEMBLY .....	22
5-CONNECTION TO ADDITIONAL DEVICES .....	30
6-LOADING THE PELLETS .....	31
7-ELECTRICAL CONNECTION.....	32
8-FIRST START-UP .....	33
9-CONTROL PANEL .....	35
10-MENU ITEMS AND OPERATION .....	36
11-SAFETY DEVICES .....	45
12-ALARMS .....	46
13-RECOMMENDATIONS FOR SAFE USE.....	50
14-CLEANING .....	51
15-TROUBLESHOOTING .....	59
16-CIRCUIT BOARD .....	62

## INTRODUCTION

Dear Customer,

Our products are designed and manufactured in accordance with standards in force, with high quality materials and using our extensive experience in the transformation processes.

To get the best performance, we suggest you read the instructions in this manual carefully.

This installation guide is an integral part of the product: ensure that the manual is always supplied with the appliance, even if it changes owner. If the manual is lost, you can request another copy from the local Technical Dept. or download it directly from the company's website.

All local regulations, including those referring to national and European standards, must be observed when installing the appliance.

In Italy, for the installation of systems with a biomass below 35KW, refer to the Ministerial Decree 37/08 and the qualified installation technician with the suitable requirements must issue a certificate of compliance for the system installed. (By system we intend Stove+Flue+Air inlet).

## REVISIONS TO THE PUBLICATION

The content of this manual is strictly technical and the property of MCZ Group Spa.





No part of this manual may be translated into other languages, adapted and/or reproduced, even in part, in other mechanical and/or electronic form or media, for photocopies, recordings or other, without the prior written authorisation of MCZ Group Spa.

The company reserves the right to make changes to the product at any time without prior notice. The owner company reserves its rights according to law.

## CARE OF THE MANUAL AND HOW TO CONSULT IT

- Take care of this manual and store it in an easily and quickly accessible place.
- Should this manual be lost or destroyed, request a copy from your retailer or directly from the authorised Technical assistance department. It can also be downloaded from the company's website.
- "**Bold text**" requires special attention.
- "*Text in italics*" is used to draw attention to other paragraphs in the manual or for any additional clarifications.
- "Note" provides the reader with additional information.

## SYMBOLS USED IN THE MANUAL

	<b>ATTENTION:</b> carefully read the relative message as <b>failure to comply with the information provided may result in serious damage to the product and danger to the persons who use it.</b>
	<b>INFORMATION:</b> failure to comply with these provisions will compromise use of the product.
	<b>OPERATING SEQUENCES:</b> sequence of buttons to be pressed to access the menus or perform adjustments.
	<b>MANUAL</b> carefully read this manual or the relative instructions.



### SAFETY WARNINGS

- **The installation, electrical connection, operating test and maintenance must only be carried out by a qualified operator.**
- **Install the product in compliance with the laws and regulations in force.**
- Only use the fuel recommended by the manufacturer. The product must not be used as an incinerator.
- It is strictly forbidden to use alcohol, petrol, liquid fuel for lanterns, diesel, bio-ethanol, fluids for lighting charcoal or similar liquids to light/rekindle the flame in these devices. Keep these flammable liquids well away from the appliance when in use.
- Do not put any fuel other than wood pellets in the hopper.
- The instructions provided in this manual must always be complied with to ensure the product and any electronic appliances connected to it are used correctly and to prevent accidents.
- **This appliance can be used by children aged 8 years and above and persons with reduced physical, sensory or mental capabilities or lack of experience and knowledge provided they are supervised or have been given instructions regarding use of the appliance in a safe way and understand the hazards involved. Children must not play with the appliance. Cleaning and maintenance to be performed by the user must not be carried out by children without supervision.**
- The user, or whoever is operating the product, must read and fully understand the contents of this installation guide before performing any operation.
- The user can only make a significant contribution to the eco-friendly operation of the heat generator if all requirements set out in the operating instructions are met.
- Dispose of combustion ash in accordance with current laws.
- Do not climb on or lean on the product.

## 1-WARNINGS AND WARRANTY CONDITIONS

- Do not dry laundry on the product. Any drying racks or the like must be kept at a safe distance from the product. **Fire hazard.**
- The product maintenance operations must be exclusively carried out by a qualified operator on a yearly basis.
- A non-compliant or improper/lack of maintenance of the product can cause hazardous situations and/or irregular operation.
- The manufacturer is relieved of any civil and criminal liability for damage caused by improper use and/or modification/tampering with the product and/or its accessory.
- We do not recommend waiting for the parts to get worn out before having them replaced.
- Only use original spare parts. The retailer, service centre or qualified personnel can provide all necessary information regarding spare parts.
- Many surfaces of the product get very hot (door, handle, glass, smoke outlet pipes, etc.). **Avoid coming into contact with these parts without adequate protective clothing or suitable equipment, such as gloves with thermal protection or “cold handle” operating systems.**
- **It is forbidden to operate the product with the door open or the glass broken. During operation, all the doors provided on the product must remain closed, with the exception of the one on the hopper which can be opened temporarily and only for the time required for topping up the fuel.**
- **The doors/covers on the appliance must remain closed when it is not being used.**
- The product must be electrically connected to a properly earthed system.
- Switch the product off in the event of a fault or malfunction.
- **Accumulated unburnt pellets in the brazier after each “failed ignition” or abnormal emptying of the pellet hopper must be completely removed before lighting again. Always check that the brazier is clean and positioned properly before lighting the product again.**

## 1-WARNINGS AND WARRANTY CONDITIONS

- Do not allow the product to come into contact with water, it contains live electrical parts.
- Do not wash the product with water (or other liquids) as they could penetrate inside the unit, damaging the electrical insulation with the risk of electrocution.
- Do not use detergents to wash the stove, they could damage the aesthetic parts of the product.
- Do not stand for a long time in front of the product in operation. Do not overheat the room you are in and where the product is installed. This may harm one's physical conditions and cause health problems.
- Install the product in rooms that do not pose a fire hazard and are equipped with power and air supplies and smoke outlets.
- In the event of fire in the chimney, turn off the device, disconnect it from the mains and do not open the door whatsoever. Then contact the competent authorities.
- The product and the cladding must be stored in a dry place and must not be exposed to weathering.
- It is recommended not to remove the feet that support the product in order to ensure adequate insulation, especially if the flooring is made of flammable materials.
- Assess the static conditions of the surface on which the weight of the product will rest and provide suitable insulation if it is made of flammable material (e.g. wood, fitted carpet or plastic).
- In the event of a malfunction of the ignition system, do not force it on by using flammable materials.
- **It is forbidden to manually load the fuel into the brazier. Failure to follow this warning can lead to hazardous situations.**

## 1-WARNINGS AND WARRANTY CONDITIONS

- The sound pressure level of this appliance does not exceed 70 dB(A).
- **Live electrical parts: only power the product once it has been fully assembled.**
- **Disconnect the product from the 230V power supply before performing any maintenance operations. The plug must be removed in such a way that an operator can verify from any point to which he/she has access, that the plug remains unplugged.**

# 1-WARNINGS AND WARRANTY CONDITIONS

## INFORMATION:

- Please contact the retailer or qualified personnel for any information, problem or malfunction.
- Only use the fuel specified by the manufacturer.
- When the product is switched on for the first time, it is normal for it to emit smoke due to the paint heating up for the first time. Therefore make sure the room it is installed in is well-ventilated.
- Periodically check and empty the inspectionable parts of the smoke duct (e.g. Tee fitting caps)
- Have the smoke outlet system periodically checked and cleaned
- The product is not a cooking appliance.
- Always keep the cover of the fuel hopper closed.
- Store this installation and user manual with care as it must accompany the product for the duration of its useful life. If the product is sold or transferred to another user, always ensure the manual is also handed over.

## INTENDED USE

The product only works with wood pellets and must be installed inside a room.

## PRODUCT PERFORMANCE CHECKS.

All our products undergo ITT TESTS carried out by a notified third party laboratory (system 3) and in accordance with Regulation (EU) number 305/2011 "Construction products", according to standard EN 14785:2006 for household appliances and "Machinery Directive" EN 303-5 for boilers.

In the case of tests for any market surveillance or inspections by third parties, please consider the following warnings:

- To reach the declared performance levels, the product must perform an operating cycle of at least 15-20 hours beforehand.
- Set the average draught of the combustion fumes as specified in the "technical product features" table
- The type of pellets used must comply with the current EN ISO 17225-2 class A1 regulation. Fir pellets are usually used for certification.
- The amount of thermal energy can vary according to the length and calorific value of the fuel. This may require some adjustments (accessed from the user menu) to comply with the hourly consumption specified in the "technical product features" table. Using class A1 pellets guarantees a calorific value that is likely to be close to that used in the product certification; the size of the pellet grains can significantly affect hourly fuel loading and consequently performance; it is therefore suggested to use pellets with a 6 mm diameter and an average length of around 24 mm (avoid pellets that are too long or excessively crushed).
- With wood-burning appliances, the fuel must comply with the current EN ISO 17225-5 class A1 regulation. Check the correct moisture of the fuel, as it must be within the range of 12 - 20% (it is best if the moisture is close to 12%, as is normally used in certification). As the fuel moisture increases, different combustion air settings are required, which are implemented from the combustion air register, thereby modifying the mixture of primary and secondary air
- It is important to check the operation of devices that can affect performance (for example air fans or electric safety devices) in case of damage due to handling.
- Nominal performance has been obtained by setting the maximum flame power and room ventilation in **manual** mode. Performance at reduced power was achieved at minimum flame and ventilation power (P1 and V1) in manual mode. The other conditions correspond to intermediate ventilation and power.
- If a "verification" mode is provided in the menu, set this function during the readings to ensure that no temperature modulation occurs due to an incorrect setting of the operating parameters.
- Lastly, strictly comply with the sampling points specified in the regulations in terms of emissions as well as temperature



## 1-WARNINGS AND WARRANTY CONDITIONS

### WARRANTY CONDITIONS

For the duration, terms, conditions, limitations of the MCZ conventional warranty, please refer to the specific warranty card that is included with the product.

### Information for management of waste electrical and electronic equipment containing batteries and accumulators



This symbol appears on the product, on the batteries, on the accumulators or on their packaging or on their documentation; it indicates that the product and the batteries or the accumulators included must not be collected, recycled or disposed of with household waste at the end of their service life.

Improper management of waste electrical and electronic equipment, batteries or accumulators can cause the hazardous substances contained within to leak out. In order to avoid harming the environment or health, the user is required to separate this equipment, and/or the batteries or accumulators included, from other types of waste and deliver them to the local collection centre. The distributor can be asked to collect the waste electrical and electronic equipment under the conditions and according to the procedures laid down by Legislative Decree 49/2014.

Separate collection and correct treatment of waste electrical and electronic equipment, batteries and accumulators contribute to conserving natural resources, respect for the environment and ensure the protection of health.

For more information on collection centres for waste electrical and electronic equipment, batteries and accumulators, contact the competent public Authorities for issue of the authorisations.

## 1-WARNINGS AND WARRANTY CONDITIONS

### WARNINGS FOR THE CORRECT DISPOSAL OF THE PRODUCT

The owner is the sole party responsible for demolishing and disposing of the product. This must be performed in compliance with laws related to safety and environmental protection in force in his/her country.

At the end of its working life, the product must not be disposed of as urban waste.

It must be taken to a special differentiated waste collection centre set up by the local authorities or to a retailer that provides this service. Separating and recycling prevents potential negative effects on the environment and health (often caused by inappropriately disposing of product parts). It also allows materials to be recovered in order to obtain significant savings in energy and resources.

The following table and the exploded view it refers to highlight the main components that can be found in the device and indications on how to separate and dispose of them correctly when no longer used.

More specifically, the electric and electronic components must be separated and disposed of in authorised centres, in compliance with the WEEE directive 2012/19/EU and the relative national transpositions.

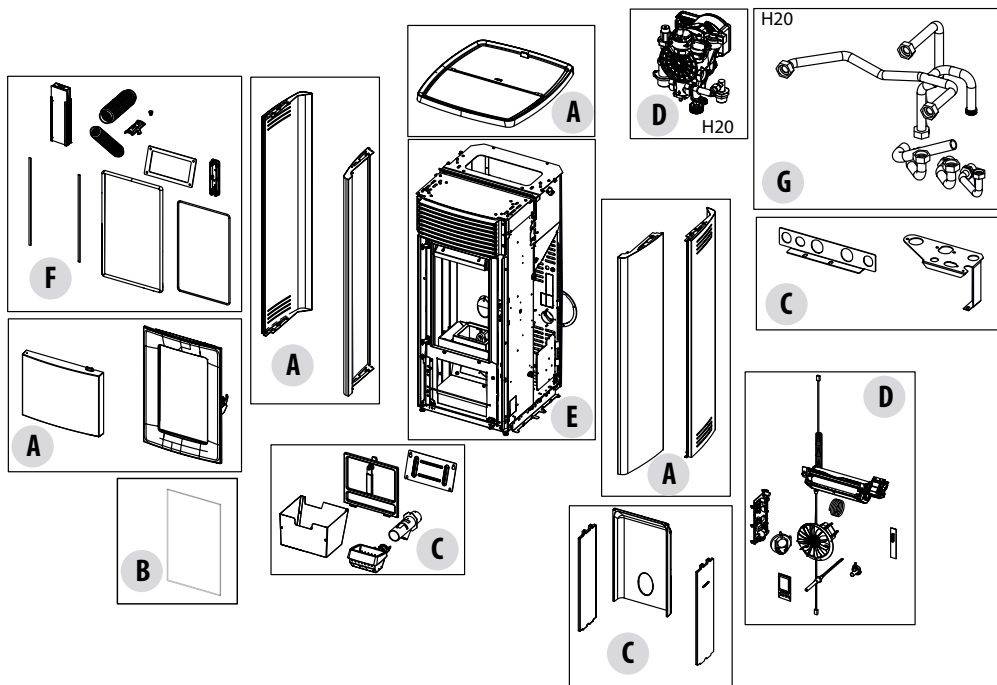

## 1-WARNINGS AND WARRANTY CONDITIONS

LEGENDA	WHERE TO DISPOSE	MATERIALS
<p style="text-align: center;"><b>A</b> OUTER CLADDING</p>	If there is any, to be disposed of separately based on the material used:	Metal
		Glass
		Tiles or ceramics
		Stone
<p style="text-align: center;"><b>B</b> GLASS DOORS</p>	If there is any, to be disposed of separately based on the material used:	Glass ceramic (fire door): to be disposed of with inert or mixed waste
		Tempered glass (oven door): to be disposed of with glass
<p style="text-align: center;"><b>C</b> INTERIOR CLADDING</p>	If there is any, to be disposed of separately based on the material used:	Metal
		Refractory materials
		Insulating panels
		Vermiculite
<p style="text-align: center;"><b>D</b> ELECTRIC AND ELECTRONIC COMPONENTS</p>	To be disposed of separately in authorised centres, as indicated in the WEEE directive 2012/19/EU and the relative national transposition.	Wiring, motors, fans, circulators, display panels, sensors ignition plug, electronic cards, batteries.
<p style="text-align: center;"><b>E</b> METAL STRUCTURE</p>	To be disposed of separately with metal	
<p style="text-align: center;"><b>F</b> COMPONENTS THAT CANNOT BE RECYCLED</p>	To be disposed of with mixed waste	E.G.: Gaskets, rube piping, silicone or fibres, plastic.
<p style="text-align: center;"><b>G</b> HYDRAULIC COMPONENTS</p>	<i>Piping, fittings, expansion vessel, valves. If there are any, to be disposed of separately based on the material they are made of:</i>	Copper
		Brass
		Stainless steel
		Other materials

## 1-WARNINGS AND WARRANTY CONDITIONS

Our solid bio-combustible products, (hereinafter called "Products") are designed and manufactured in compliance with one of the following European standard harmonised to Regulation (UE) no. 305/2011 for construction products:

**EN 14785:** "Residential space heating appliances fired by wood pellets"

**EN 13240:** "Room heaters fired by solid fuel."

**EN 13229:** "Inset appliances including open fires fired by solid fuels"

**EN 12815:** "Residential cookers fired by solid fuel"

The products also comply with the essential requirements of Directive **2009/125/EC (Eco Design)** and, where applicable, Directives:

**2014/35/EU** (LVD - Low Voltage directive)

**2014/30/EU** (EMC - Electromagnetic Compatibility directive)

**2014/53/EU** (RED – Radio Equipment directive)

**2011/65/EU** (ROhS)

The EC Declaration of Conformity, the Declaration of Performance required by EU Regulation 305/2011 and the Product Data Sheet required by Regulations (EU) 2015/1185 and 2015/1186 can be downloaded by scanning the QR code on this page (also found on the product label) or by accessing the website page [www.mczgroup.com/support/mcz](http://www.mczgroup.com/support/mcz) and following the simple instructions.



Having specified the above, we highlight and report that:

- **This manual and technical data sheet, also available on our website**, bear all of the specific indications and necessary and essential information to choose the product, to install it correctly and to properly size the smoke expulsion system;
- the Products must be **installed, controlled and serviced** by a qualified operator, according to the instructions in this manual and in compliance with the laws and installation and maintenance standards in force in individual countries, so as to provide an efficient heating system, properly sized according to the needs of the home;
- **if the Products are thermally stressed**, constantly operating for several hours at high power (e.g. 3, 4 hours a day at outputs P4 or P5), we recommend more frequent cleaning and reducing the interval between routine maintenance operations according to the operating condition of the product. We furthermore point out that these operating conditions increase the risk of premature wear of the product, especially those parts exposed to the direct heat of the fire (e.g. combustion chamber), the original condition of which can undergo modifications and deterioration which, among other things, could generate noise during operation of the unit due to mechanical expansion.

The manufacturer will not be held liable if the above information is ignored.

## 2-INSTALLATION



**The instructions in this chapter refer explicitly to the Italian installation regulation UNI 10683. In any case, always observe the regulations in force in the country of installation.**

### PELLETS

The pellet is obtained from natural dried wood sawdust (without paint). The compactness of the material is guaranteed by the lignin contained in the wood itself, without glue or binders.

The market offers different types of pellets with characteristics that vary according to the wood mixtures. The most common diameter on the market is 6 mm (although 8 mm diameter is also available) with a length, on average, between 3 and 40 mm. A good quality pellet has a density of between 600 and 750 or more kg/cubic metres and a moisture content that accounts for 5 to 8% of its weight.

Pellets have technical advantages besides being an ecological fuel, as the wood residue is used completely, thereby achieving cleaner combustion than that of fossil fuels.

While good-quality wood has a calorific value of 4.4 kW/kg (15% moisture, after about 18 months of seasoning), that of pellets is around 4.9 kW/kg. To ensure good combustion, the pellets must be stored in a dry place and protected from dirt. Pellets are usually supplied in 15 kg bags, therefore, storing them is very convenient.



BAG OF PELLETS 15 kg

Good quality pellets guarantee good combustion, thereby decreasing harmful emissions into the atmosphere.



***The poorer the quality of the fuel, the more often the internal parts of the brazier and combustion chamber need to be cleaned.***

The main quality certifications for pellets currently available on the European market guarantee that the fuel complies with class A1/A2 according to ISO 17225-2. These certifications include, for example, ENPlus, DINplus, Ö-Norm M7135, and specifically assure that the following characteristics are complied with:

- calorific value: 4.6 - 5.3 kWh/kg.
- Water content:  $\leq 10\%$  of the weight.
- Percentage of ash: max 1.2% of the weight (A1 less than 0.7%).
- Diameter:  $6\pm 1/8\pm 1$  mm.
- Length: 3-40 mm.
- Content: 100% untreated wood without the addition of binding agents.



***The company recommends using certified fuel for its products (ENPlus A1, DINplus, Ö-Norm M7135). The use of pellets that do not comply with the characteristics specified previously may compromise the operation of your product and therefore invalidate the warranty and product liability.***

## 2-INSTALLATION

### FOREWORD

**The heating system (generator + combustion air supply + combustion product expulsion system + any hydraulic/aerualic system) must be installed in compliance with the laws and regulations in force<sup>1</sup>, and carried out by a qualified technician, who must issue a declaration of conformity of the system to the system manager and shall undertake full responsibility for final installation and consequent good operation of the product.**

The manufacturer declines all responsibility in the event of installations that do not comply with the laws and regulations in force and inappropriate use of the appliance.

In particular one must ensure that:

- the environment is suitable for installing the appliance (floor load-bearing capacity, presence or possibility of creating an adequate electrical/hydraulic/aerualic system when required, volume compatible with the appliance characteristics, etc.);
- the appliance is connected to a smoke expulsion system correctly sized according to EN 13384-1, which is resistant to soot fire and which complies with the distances prescribed by the combustible materials indicated on the plate data;
- there is a suitable combustion air flow to the appliance;
- other combustion appliances or extraction devices installed do not cause a negative pressure of more than 4 Pa in the room where the product is installed compared to the outside (only sealed appliances are allowed a maximum of 15 Pa of negative pressure in the room).

<sup>1</sup>The national reference standard for the installation of domestic appliances is UNI 10683 (IT) - DTU NF 24.1 (FR) - DIN 18896 (DE) - NBN B 61-002 (BE) - Real Decreto 1027/2007 (ES)

**In particular, it is recommended to strictly observe the safety distances from combustible materials to avoid serious harm to people and to the integrity of the home.**

Installation of the appliance must ensure easy access to service the appliance itself, the smoke channels and the flue.

Always maintain adequate distance and protection in order to prevent the product from coming into contact with water.

**It is forbidden to install the stove in rooms with a fire hazard.**

**With the exception of sealed installations, it is also forbidden for liquid fuel appliances with continuous or intermittent operation that draw the combustion air from the room they are installed in or B-type gas heating appliances, with or without the production of domestic hot water, to coexist in the same room or in interconnecting rooms.**



***Sealed installation means that the product is certified as sealed and its installation (ducting of the combustion air and connection to the chimney) is airtight with respect to the installation environment.***

A sealed installation does not consume the room's oxygen but draws all the air from the outer environment (if suitably ducted) and makes it possible to install the product, therefore, it can be installed in all houses that require a high degree of insulation such as "passive" or "high energy efficiency" houses. Thanks to this technology there is no risk of smoke emissions in the room, hence no air inlets and relevant ventilation grilles are required in the installation premises.

Consequently, there will be no more draughts of cold air in the room, which would otherwise make it less comfortable and reduce the overall efficiency of the system. The sealed stove may even be installed in a sealed installation that is compatible with the presence of forced ventilation or in premises that might have negative pressure with respect to the outside.

## 2-INSTALLATION

### MINIMUM DISTANCES

Observe the distances from flammable objects (sofas, furniture, wood panelling, etc..) as specified in the following diagram.

If objects considered to be particularly sensitive to heat are present, such as furniture, curtains or sofas, as a precaution, increase the stove clearances substantially to avoid possible deterioration due to the effect of heat.

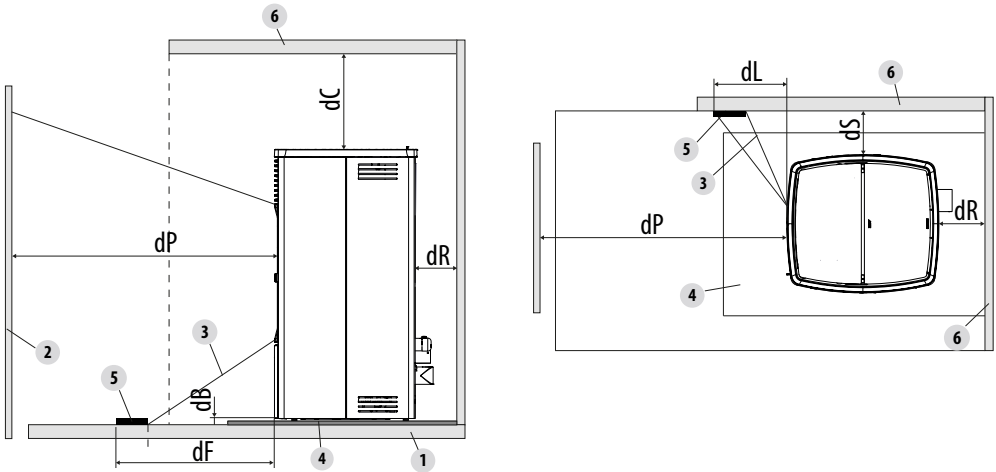

	Safety distance from combustible material (mm)
dR (rear distance)	50
dS (side distance)	100
dB (lower distance)	0
dC (upper distance)	800
dP (front radiation)	1000
dF (floor radiation)	1000
dL (side radiation)	1000

### KEY

1	FLOOR	4	FLOOR GUARD
2	FRONT FLAMMABLE MATERIAL	5	RADIATED SURFACE TO BE PROTECTED
3	AREA SUBJECT TO RADIATION	6	REAR/SIDE/UPPER FLAMMABLE SURFACE

If the floor is made of combustible material, use a protection made of non-combustible material (steel, glass...) that also protects the front from any falling combusted material during cleaning operations.



**Always fit a floor guard if the floor is made of flammable material.**

Install the stove also detached from any non-combustible walls/surfaces, observing a minimum clearance of 50 mm (back) and 100 mm (side) to allow effective aeration of the appliance and a good distribution of heat in the room.

## 2-INSTALLATION

In any case, ensure adequate distance to facilitate access during cleaning and extraordinary maintenance. If this is not possible, it must still be possible to distance the product from adjacent walls/elements.

This operation must be performed by a technician qualified to disconnect the combustion product expulsion ducts and their subsequent restoration.

For generators connected to the hydraulic system, a connection must be provided between the system itself and the product so that, during extraordinary maintenance, carried out by a qualified technician, it is possible to move the generator by at least 50 cm from adjacent walls without emptying the system (e.g. by using a double shut-off gate or suitable flexible connection).

### Air inlet

It is mandatory to provide an adequate external air inlet that supplies the combustion air required for the product to work properly. The flow of air between the outside and the installation room can take place with a free air inlet or by channelling the air directly to the outside<sup>3</sup>.

The free air inlet must:

- be made at floor level
- always be protected with an outer grille and in such a way that it cannot be obstructed by any object
- have a minimum total free area of 80 cm<sup>2</sup> (net of the grille)

The presence of other suction devices (e.g.: vmc, electric fan for stale air extraction, kitchen hood, other stoves, etc.), in the same room could cause negative pressure in the room. In this case, with the exception of sealed installations, one must verify that, with all the equipment on, no more than 4 Pa of negative pressure is created inside the installation room with respect to the outside. If necessary, increase the air inlet section.

It is possible to duct the air required for combustion to the outside by connecting the external air inlet directly with the combustion air inlet which is usually found on the back of the appliance.

The duct must comply with the following dimensions (each 90° bend is equivalent to one linear metre):

<sup>3</sup> in the event the combustion air is ducted on unsealed products, still verify that no more than 4 Pa of negative pressure is created inside the installation room with respect to the outside, otherwise provide for an additional air intake in the room.



## 2-INSTALLATION

Below 15kW:

Air duct diameter	Maximum length (smooth duct)	Maximum length (corrugated duct)
50mm	2m	1m
60mm	3m	2m
80mm	7m	4m
100mm	12m	9m

Above 15kW:

Air duct diameter	Maximum length (smooth duct)	Maximum length (corrugated duct)
50mm	-	-
60mm	1m	-
80mm	3m	1m
100mm	7m	4m

## 2-INSTALLATION

### Preparing the smoke expulsion system

The combustion product expulsion system is a particularly important element for the proper operation of the appliance and must be correctly sized according to EN 13384-1.

Its creation/adaptation/verification must always be carried out by a legally qualified operator and must comply with the regulations in force in the country where the appliance is installed.

The Manufacturer declines all liability for malfunctions caused by a badly sized and non-compliant smoke expulsion system.

### Smoke duct (smoke fitting)

The smoke duct is the pipe that connects the appliance to the flue.

This smoke fitting must comply in particular with the following requirements:

- comply with product standard EN 1856-2;
- its cross-section must be of constant diameter and no less than that of the appliance outlet, from the firebox outlet up to the connection in the flue;
- the horizontal section must be as short as possible and extend no more than 4 metres;
- the horizontal sections must have a minimum upward slope of 3%;
- changes of direction must have an angle no greater than 90° and be easy to inspect
- the number of changes of direction, including that for entry into the flue, and exclusion of the T in the event of a side or rear outlet, must not exceed 3;
- it must be insulated if it passes outside the installation room
- it must not in any case cross rooms in which it is forbidden to install combustion appliances.
- the use of flexible metal and fibre cement or aluminium hoses is forbidden;

In any case, smoke ducts must be sealed against combustion products and any condensation. For this reason, it is recommended to use pipes with silicone gaskets or similar sealing devices that withstand the operating temperatures of the appliance (e.g. T200 P1) and that by removing the gaskets, are still T400 N1 G certified.

### Flue (chimney or piped duct)

When creating the flue, in particular comply with the following requirements:

- comply with the applicable product standard (EN 1856, EN 1857 EN 1457, EN 1806, EN 13063...);
- be made with suitable materials to ensure resistance to normal mechanical, chemical, thermal stresses and have adequate thermal insulation in order to limit the formation of condensate;
- have a predominantly vertical configuration and be free of choke points along its entire length;
- be correctly spaced by air gaps and isolated from combustible materials;
- the flue inside the house must still be insulated and can be inserted in an air shaft provided it complies with the regulations for piping;
- the smoke duct must be connected to the flue by means of a Tee fitting with an inspectable collection chamber for the collection of soot and any condensate.
- where the sizing provides for wet operation, a suitable condensate collection and siphon discharge system must be set up.



***We recommend checking the data plates of the flue for the safety distances that must be observed in the presence of combustible materials and, if necessary, the type of insulating material to be used.***

***It is forbidden to connect the stove to a collective or shared flue (\*) with other combustion appliances or with hood outlets.***

***It is forbidden to use the direct drain on the wall or towards indoor spaces and any other form of drain not provided for by the regulation in force in the country of installation.***

## 2-INSTALLATION

### Chimneypot

The chimneypot, meaning the end part of the flue, must meet the following characteristics:

- the smoke outlet section must be at least double the internal section of the chimney;
- prevent the penetration of rain or snow;
- ensure the outlet of smoke even in the event of wind (windproof chimneypot);
- the height of outflow must be beyond the reflux area (\*) (refer to national regulations to identify the reflux area);
- always be built at a distance from antennas or dishes, and never be used as a support.

(\*) unless there are specific national derogations (clearly specified in the corresponding instruction manual in English) which under appropriate conditions allow it; in this case, strictly follow the product/installation requirements of the relative regulations/technical specifications/legislation in force in that country.

## 2-INSTALLATION

### EXAMPLES OF INSTALLATION<sup>4</sup> (DIAMETERS AND LENGTHS TO BE SIZED)

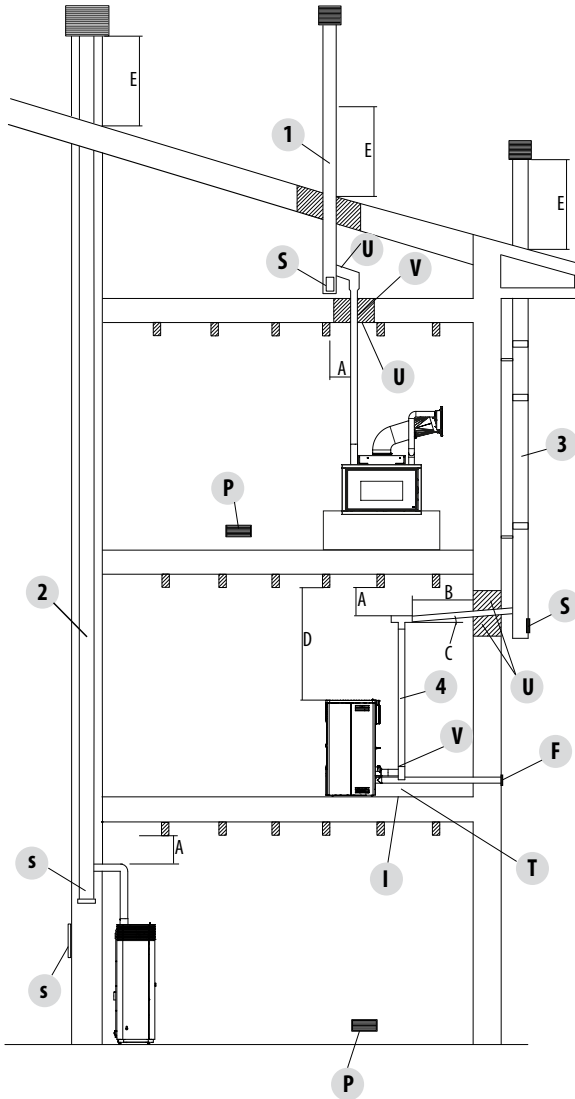

1. Flue installation with hole for the passage of the pipe increased by:

- minimum 100mm around the pipe if next to non-flammable parts such as cement, brick, etc.; or
- minimum 300mm around the pipe (or as required by plate data) if next to flammable parts such as wood etc.

In both cases, install suitable insulation between the flue and the ceiling.

Always check and comply with the plate data of the flue, specifically the minimum safety distances from combustible materials.

The previous rules also apply for holes made in walls.

2. Old flue, pipe with the inclusion of an external access door for chimney cleaning.

3. External flue made of insulated stainless-steel pipes, i.e. with double walls: all securely mounted on the wall. With windproof chimney pot.

4. Ducting system using Tee fittings that allow easy access for cleaning without having to remove the pipes

- U=INSULATION  
 V=POSSIBLE DIAMETER INCREASE  
 I=INSPECTION CAP  
 S=INSPECTION ACCESS PANEL  
 P=AIR INLET  
 T=TEE FITTING WITH INSPECTION CAP  
 A=DISTANCE FROM FLAMMABLE MATERIAL (SMOKE DUCT PLATE)  
 B=MAXIMUM 4 M  
 C=MINIMUM 3° SLOPE  
 D=DISTANCE FROM FLAMMABLE MATERIAL (APPLIANCE PLATE)  
 E=REFLUX AREA  
 F=AIR DUCTING

<sup>4</sup>The figure shows typical, but not exhaustive, examples of all possible installations (which must always be approved by a qualified technician)

### 3-DRAWINGS AND TECHNICAL FEATURES

#### DRAWINGS AND CHARACTERISTICS

##### GIO' AIR 8 S1 STOVE DIMENSIONS

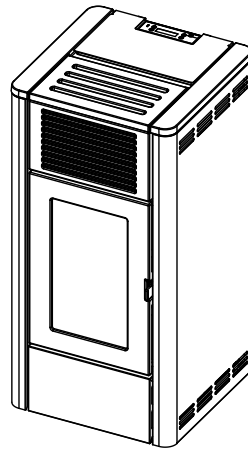
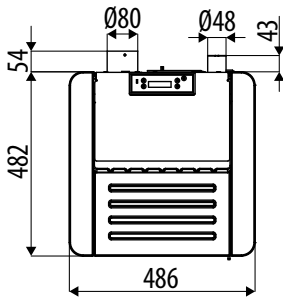
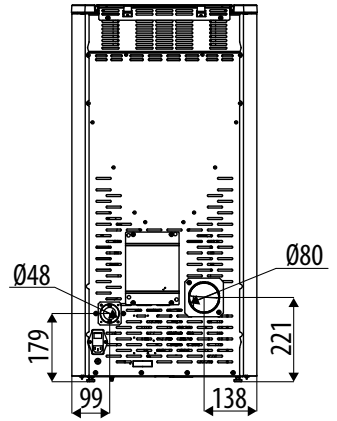
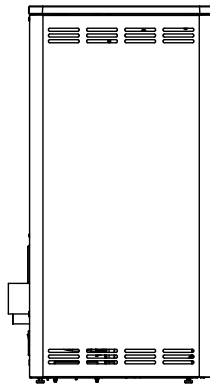
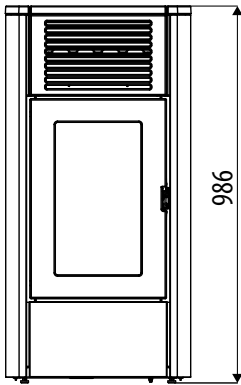

### 3-DRAWINGS AND TECHNICAL FEATURES

TECHNICAL CHARACTERISTICS	GIO' AIR 8 S1
Energy Efficiency Class	A+
Nominal output power	8.0 kW (6880 kcal/h)
Minimum power output	2.5 kW (2150 kcal/h)
Efficiency at Max	90.4%
Efficiency at Min	92.0%
Temperature of exhaust smoke at Max	196 °C <sup>(1)</sup>
Temperature of exhaust smoke at Min	103 °C <sup>(1)</sup>
Particulate/OGC/Nox (13%O <sub>2</sub> )	16 mg/Nm <sup>3</sup> - 1 mg/Nm <sup>3</sup> - 137 mg/Nm <sup>3</sup>
CO at 13% O <sub>2</sub> at Min and at Max	0.055 – 0.003%
CO <sub>2</sub> at Min and at Max	7.4% - 14.1%
Recommended draught at Max power	0.10 mbar - 10 Pa***
Minimum draft allowed at minimum power	0.05 mbar - 5 Pa
Smoke mass	4.3 g/sec
Tank capacity	32 litres
Type of pellet fuel	Pellet diameter 6 mm and size 3 ÷ 40 mm
Pellet hourly consumption	Min ~ 0.6 kg/h* - Max ~ 1.8 kg/h*
Autonomy	At min ~ 35 h* - At max ~ 12 h*
Heatable volume m <sup>3</sup>	145/55 – 229/35 – 400/20 **
Combustion air inlet	Ø 50 mm
Smoke outlet	Ø 80 mm
Air inlet	80 cm <sup>2</sup>
Rated electrical power (EN 60335-1)	70 W (Max 350 W)
Supply voltage and frequency	230 Volt / 50 Hz
Net weight	140 kg
Weight with packaging	150 kg
Distance from combustible material (back/side/under)	50 mm /100mm / 0 mm
Distance from combustible material (ceiling/front)	800 mm / 1000 mm

\* Data that may vary depending on the type of pellets used

\*\* Volume that can be heated, according to the power requirement per m<sup>3</sup> (respectively 55-35-20 W per m<sup>3</sup>)

\*\*\*Value recommended by the manufacturer (non-binding) for optimal product operation

**Tested according to EN 14785 in accordance with European regulation for Construction Products (EU 305/2011)**

**<sup>(1)</sup> To properly size the chimney (in accordance with EN 13884-1), use the smoke temperature exactly detected at the outlet of the appliance, or the above stated temperature increased by 20% (e.g. stated temperature 100°C: product outlet temperature 120°C)**

**INFORMATION REQUIREMENTS FOR SOLID FUEL LOCAL SPACE HEATERS  
ACCORDING TO COMMISSION REGULATIONS (EU) 2015/1185 - (EU) 2015/1186 (PRODUCT FICHE)**

Manufacturer: **MCZ GROUP SpA**  
 Trademark: **MCZ**  
 Model Identifier: **GIO' AIR 8 S1**

Indirect heating functionality: **NO**  
 Direct heat output (space heat output): **8,0 kW**  
 Indirect heat output (water heat output): **kW**  
 CPR harmonised standard: **EN 14785:2006**  
 Product description: **Mechanically fed roomheater burning wood pellets**

Notified Body: **ACTECO SRL (N.B. 1880)**  
**Via Amman 41, 33084 Cordenons (PN), IT**

Fuel	Preferred fuel:	Other suitable fuel(s):	$\eta_s$ [%]	EEl [%]
Log wood, moisture content $\leq 25$ %	<b>NO</b>	<b>NO</b>		
Compressed wood with moisture content < 12 %	<b>YES</b>	<b>NO</b>	<b>79,2</b>	<b>120</b>
Other woody biomass	<b>NO</b>	<b>NO</b>		

Observe the specific precautions for installation, assembly and maintenance indicated in the manual accompanying the product, and the national and local rules in force

**Energy Efficiency Class** **A+** (A+++ / G scale)

**Characteristics when operating with the preferred fuel:**

Space heating emissions (mg/Nm <sup>3</sup> at 13% O <sub>2</sub> )	CO	NO <sub>x</sub>	OGC	PM
at Nominal heat output	<b>37</b>	<b>137</b>	<b>1</b>	<b>16</b>
at Minimum heat output	<b>679</b>	<b>131</b>	<b>1</b>	<b>27</b>

Heat output			
Item	Symbol	Value	Unit
Nominal heat output	$P_{nom}$	<b>8,0</b>	kW
Minimum heat output (indicative)	$P_{min}$	<b>2,5</b>	kW
Useful efficiency (NCV as received)			
Useful efficiency at nominal heat output	$\eta_{Th,nom}$	<b>90,4</b>	%
Useful efficiency at minimum heat output (indicative)	$\eta_{Th,min}$	<b>92,0</b>	%
Auxiliary electricity consumption			
At nominal heat output	$e_{l,max}$	<b>0,070</b>	kW
At minimum heat output	$e_{l,min}$	<b>0,030</b>	kW
In standby mode	$e_{l,cb}$	<b>0,002</b>	kW







Type of heat output/room temperature control (select one)	
single stage heat output, no room temperature control	NO
two or more manual stages, no room temperature control	NO
with mechanic thermostat room temperature control	NO
with electronic room temperature control	NO
with electronic room temperature control plus day timer	NO
with electronic room temperature control plus week timer	YES
Other control options (multiple selections possible)	
room temperature control, with presence detection	NO
room temperature control, with open window detection	NO
with distance control option	NO

## 4-INSTALLATION AND ASSEMBLY

### INSTRUCTIONS FOR PACKAGING DISPOSAL

The material that the appliance's packaging is made of must be managed correctly, in order to make collection, reuse, recovery and recycling easier, where possible.

The table below illustrates the possible components that the packaging is made of, and the relative instructions for correct disposal.

DESCRIPTION	CODE MATERIAL	SYMBOL	DIRECTIONS FOR COLLECTION
WOOD BED	WOOD FOR 50		SORTED waste collection
WOOD CAGE			WOOD
WOOD PALLET			Check with the competent body on how to dispose of this packaging at the recycling depot
CARDBOARD BOX	CORRUGATED CARDBOARD PAP 20		SORTED waste collection
CARDBOARD CORNER			PAPER
CARDBOARD SHEET			Check the instructions of the competent body
APPLIANCE BAG	POLYETHYLENE LD-PE 04		SORTED waste collection
BAG OF ACCESSORIES			PLASTIC
BUBBLE WRAP			Check the instructions of the competent body
PROTECTIVE SHEET			
LABELS			
POLYSTYRENE	POLYSTYRENE PS 06		SORTED waste collection
FOAM PEANUTS			PLASTIC
			Check the instructions of the competent body
STRAP	POLYPROPYLENE PP 05 POLYESTER PET 01	 	SORTED waste collection
TAPE			PLASTIC
			Check the instructions of the competent body.
SCREWS	IRON FE 40		SORTED waste collection
STAPLES FOR STRAP			METAL
FASTENING BRACKET			Check with the competent body on how to dispose of this packaging at the recycling depot



## 4-INSTALLATION AND ASSEMBLY



Handle the product with suitable means paying attention to the applicable safety regulations in force. Do not turn the packaging over and handle the majolica parts with care.

The stove is delivered in a single package. Open the package, remove the two screws "v" which secure the stove brackets to the pallet and then remove the bracket "S" from the stove foot. There are four brackets, two at the front and two at the back.

Install the stove in the chosen area, making sure it complies with the requirements.

The stove body or unit must always be kept in a vertical position when handled, and handled using carts only. Pay particular attention to the door and its glass, protecting them from mechanical knocks that would compromise their integrity.

The product must always be handled with care. If possible, unwrap the stove near the chosen area of installation. The packaging materials are neither toxic nor harmful, therefore no particular disposal measures are required.

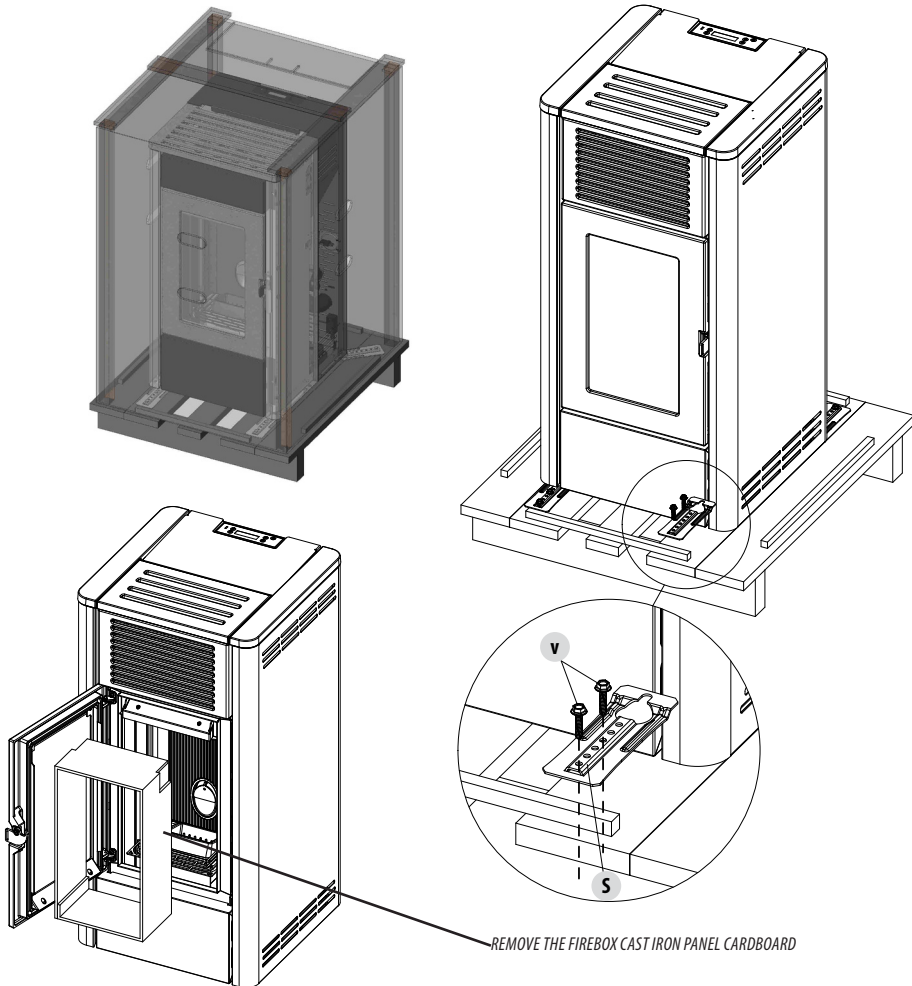

REMOVE THE FIREBOX CAST IRON PANEL CARDBOARD

## 4-INSTALLATION AND ASSEMBLY

Therefore, the end user is responsible for product storage, disposal or possible recycling in compliance with the relative applicable laws in force. Do not store the stove unit or its cladding without their packaging.

Position the stove and connect it to the flue pipe. Remove the plastic clamp securing the top to the stove's frame. If the stove needs to be connected to an outlet pipe which goes through the rear wall (to connect to the flue), take utmost care to make sure that the joint is not forced.



***If the stove smoke outlet is forced or used improperly to lift it or position it, the operation of the stove can be damaged irreparably.***

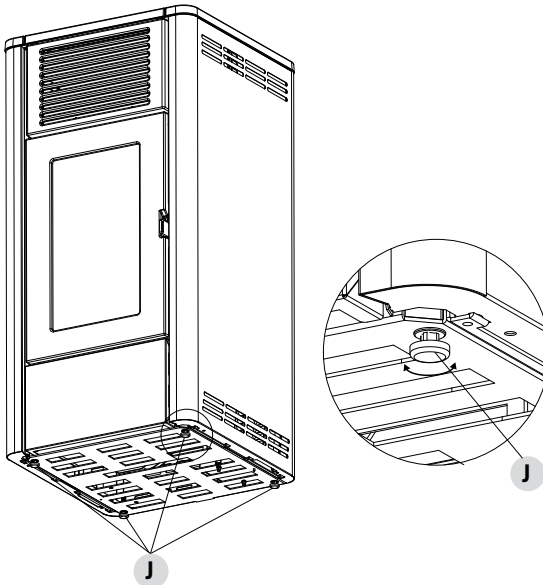

1. TURN THE FEET CLOCKWISE TO LOWER THE STOVE
2. TURN THE FEET COUNTER CLOCKWISE TO RAISE THE STOVE

## 4-INSTALLATION AND ASSEMBLY

### DISASSEMBLING THE TOP

Lift the tank cover "B" and remove the top "A". To remove the top "A", simply lift it off its rubber supports and put it in a safe place until it is to be used again.

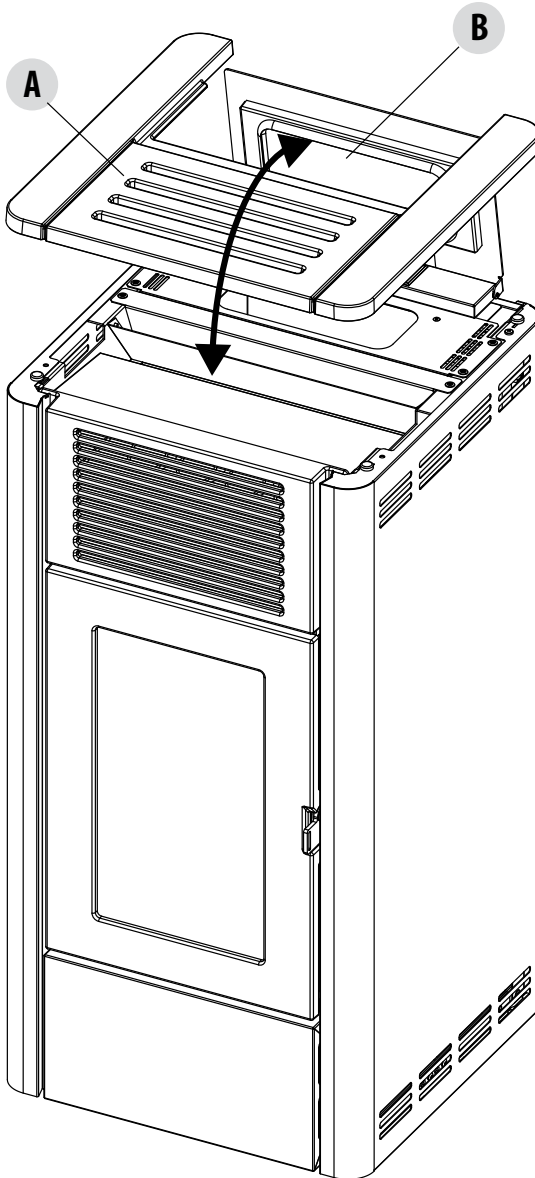

## 4-INSTALLATION AND ASSEMBLY

### REMOVING THE SIDE PANEL

The stove is delivered fully assembled; if you need to remove the side panels for technical service or cleaning, proceed as follows:

- raise the cover of the pellet tank "B"
- remove the top "A"
- in the upper section, remove the two screws "x" under top "A" securing the panel "C" to the structure
- lift the panel "C" upwards to free the four holes "r" from the four pins "p" in the structure of the stove.
- place the panel "C" in a safe place

Proceed in the same way also with panel "D"

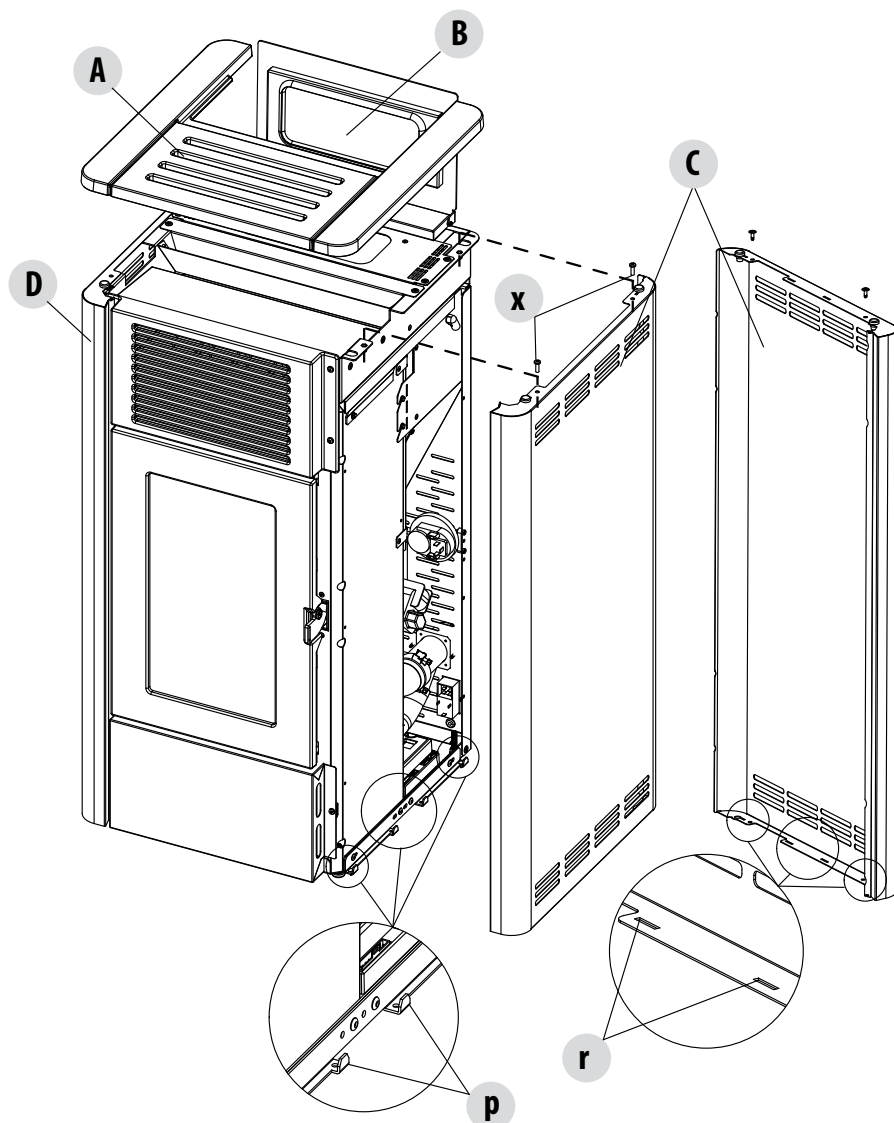

## 4-INSTALLATION AND ASSEMBLY

### DISASSEMBLING THE FRONT PANELS

After removing the side panels "C" and "D", proceed as follows:

- Undo the four screws "v" and remove the upper front panel "E"
- Undo the two screws "z" and remove the lower front panel "F"

Put the panels "E" and "F" in a safe place.

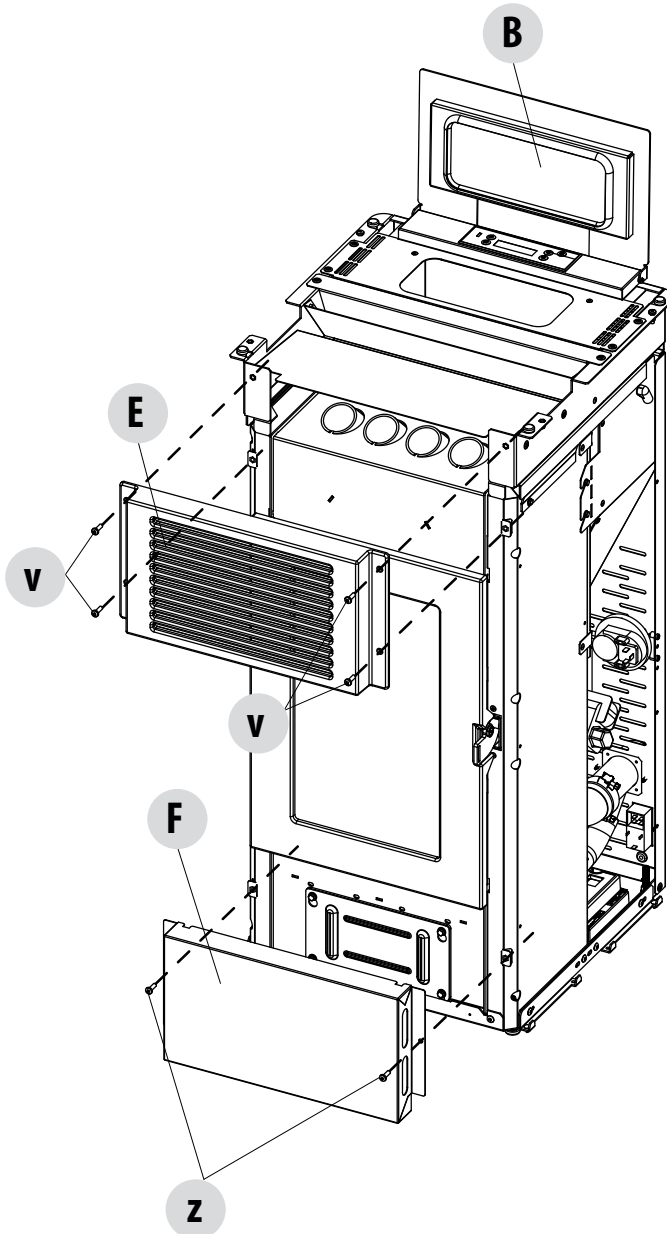

## 4-INSTALLATION AND ASSEMBLY

### ACCESS TO THE ELECTRONIC BOARD

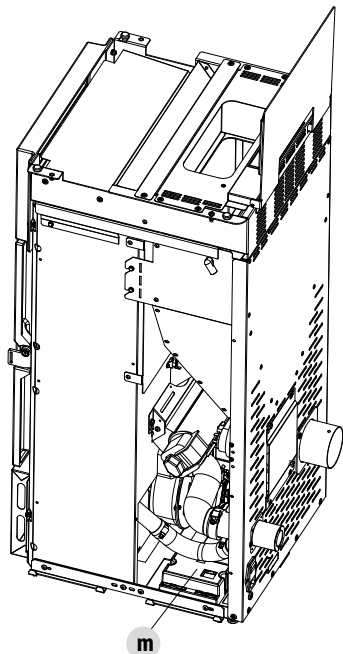

The electronics board “m” is on the right side (handle side). If you need to access the board, you must remove the back side panel as explained above.

### ACCESS TO THE GEARMOTOR

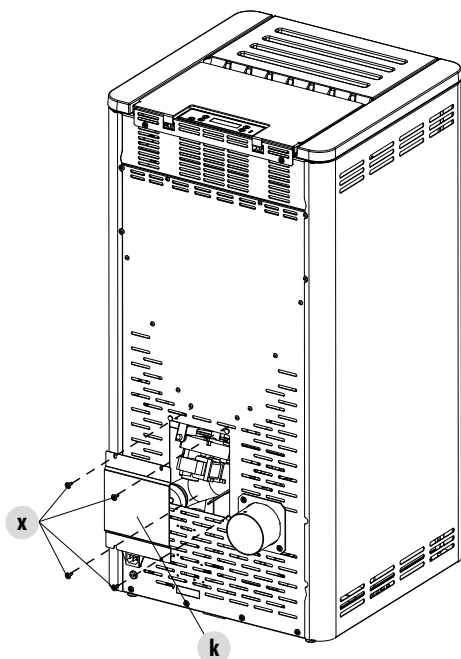

To access the gearmotor, you must remove the four screws “x” from the stove’s back panel and then remove the plate “k”.

## 4-INSTALLATION AND ASSEMBLY

### OPENING THE DOOR OF THE FIREBOX

To open the firebox door, fit the cold handle "F" into its hole in the handle, and pull it outwards.



#### **Attention!**

*The firebox door must be closed properly for the stove to work correctly.  
Only open the doors when the stove is switched off and cold.*

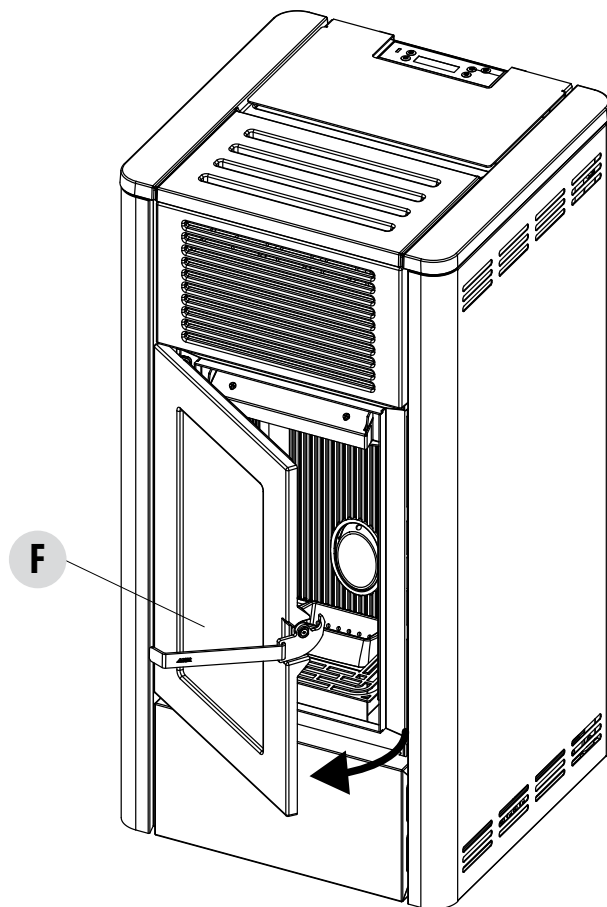

## 5-CONNECTION TO ADDITIONAL DEVICES

### INSTALLING THE MODEM / PROGRAMMABLE THERMOSTAT (OPTIONAL)

To install the thermostat and the mode, refer to their instruction manuals.

The modem mounts to the stove's back panel with adhesive velcro, while the programmable thermostat's receiver "U" mounts onto the provided holes. Once the receiver "U" has been secured with the provided screws, break the knockout hole "V" and route the cables for connection to the board through it.

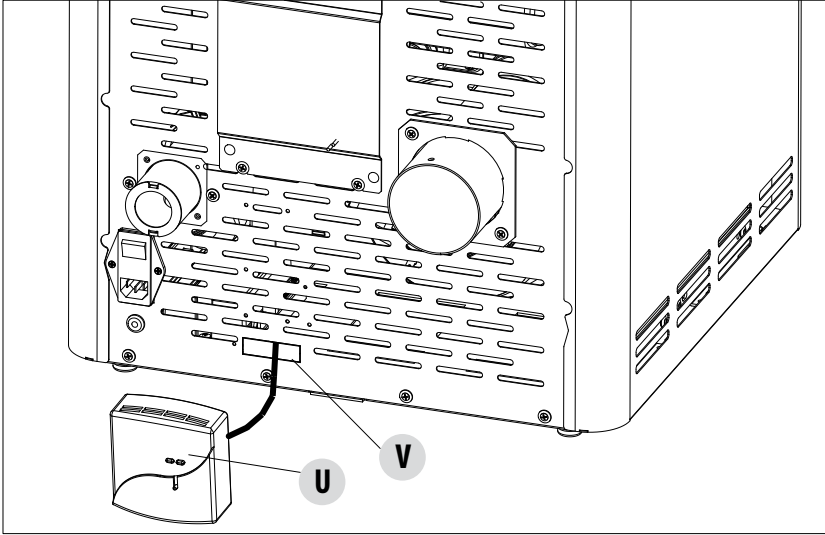

### INSTALLATION OF WIFI PANEL (OPTIONAL-CODE 4020003)

Use the knockout hole at the back of the stove to install the Easy Connect WiFi panel and follow the installation instructions found inside the product. The WiFi panel must be connected to the board on the stove using the supplied cable.

In order to use the WiFi system, download the Easy Connect app and follow the set-up instructions.

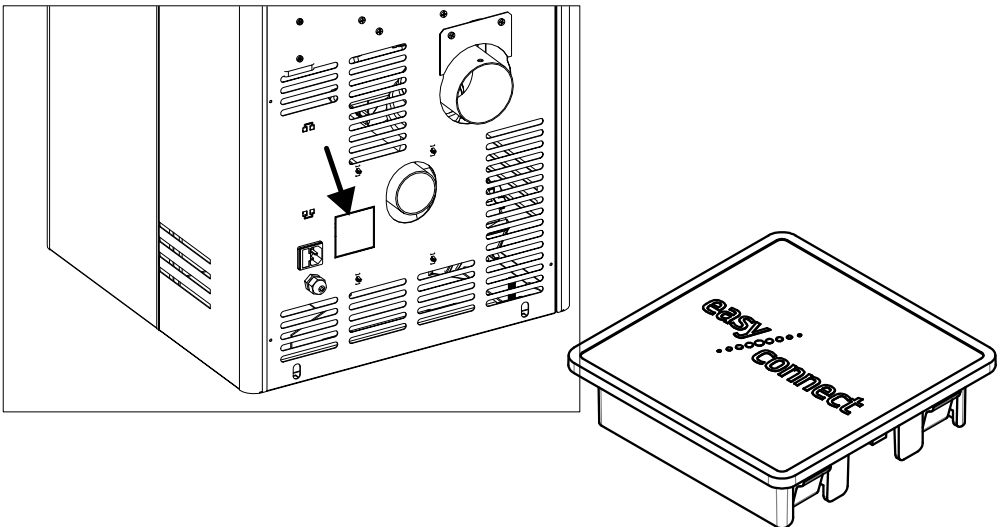



## 6-LOADING THE PELLETS

### LOADING THE PELLETS

The fuel is loaded from the top of the stove by lifting the hatch "B" with the included cold handle "G".  
Pour the pellets in slowly so that they are deposited at the bottom of the hopper.



*If loading pellets when the stove is running, open the door of the tank using the stove mitten that comes with the stove itself.*



*When loading, do not let the pellet bag come into contact with hot surfaces.*

*Never remove the protection grid inside the tank.*

*No other type of fuel other than pellets is to be inserted into the tank, in compliance with above-mentioned specifications.*

*Store the spare fuel at an adequate safe distance.*

*Do not pour pellets directly onto the brazier but only into the tank.*

*When the appliance is running and when it is turned off, most of the stove surfaces are very hot (door, handle, glass, smoke outlet pipes, etc.). Therefore it is recommended to avoid coming into contact with these parts.*

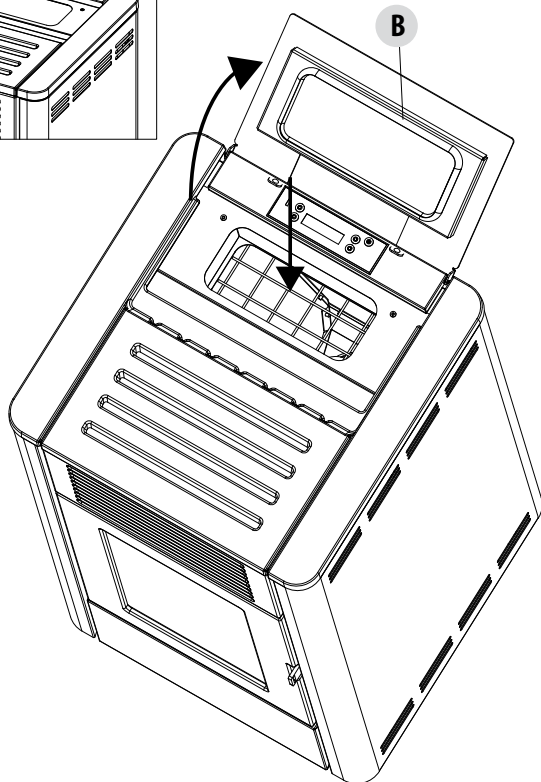
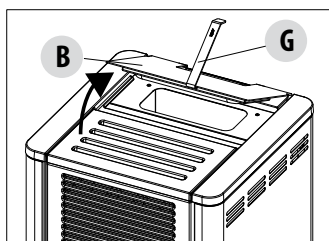

LOADING THE PELLETS

## 7-ELECTRICAL CONNECTION

### ELECTRICAL CONNECTION

First connect the power cable to the back of the stove and then to a wall socket.



*It is recommended to disconnect the power cable when the stove is not used.*

*The cable must never come into contact with the smoke exhaust pipe or any other part of the stove.*

### STOVE POWER SUPPLY

Connect the power cable to the back of the stove and then to a wall socket. The stove is then powered.

There is a fuse box also in the switch block next to the power socket. Open this compartment by simply lifting the cover, using a screwdriver as a lever from inside the power outlet compartment. Inside there are two fuses (5x20 mm T delayed / 3.15 A 250 V), which may need to be replaced if the stove is not powered (e.g. the control panel display does not light up) - operation to be implemented by an authorised and skilled technician.

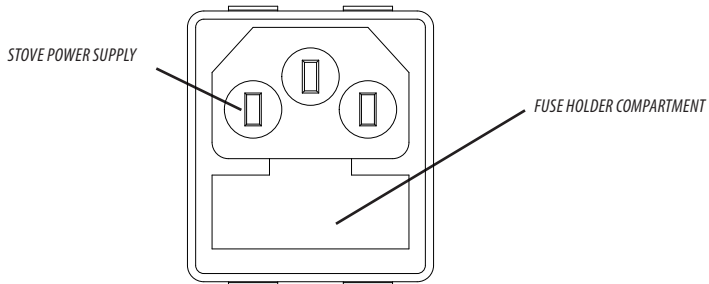

#### **ATTENTION!**

*All cleaning and / or replacement of parts must be carried out with the electric plug disconnected.  
Disconnect the product from the 230V power supply before performing any maintenance operations.  
If the cable is damaged, replace it.*

### ROOM PROBE

The room probe (B) is located at the back of the stove near the switch.

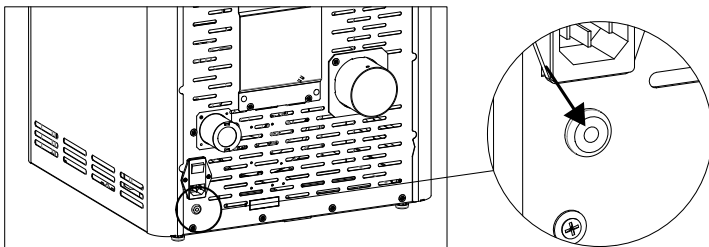

## 8-FIRST START-UP

### PRECAUTIONS BEFORE START-UP

#### GENERAL PRECAUTIONS

Remove any objects that may burn from the brazier (manual, various adhesive labels or any polystyrene).

**Check that the brazier is positioned correctly and rests properly on the base.**



*The first start-up may not be successful as the feed screw is empty and does not always manage to load the required amount of pellets in time to light the flame.*



**CANCEL THE FAILED IGNITION ALARM BY PRESSING AND HOLDING THE ON/OFF KEY FOR A FEW SECONDS. REMOVE THE PELLET LEFT IN THE BRAZIER AND REPEAT THE START-UP.**

### SETTINGS TO BE CARRIED OUT BEFORE THE INITIAL START-UP

First connect the power cable to the back of the stove and then to a wall socket.

To switch the stove on and off, press the button **1** on the control panel or press the button **3** from the remote control (optional accessory). The display on the panel will be ON with a flashing flame. When the flame stops blinking, the stove has reached the operating condition to "supply power".

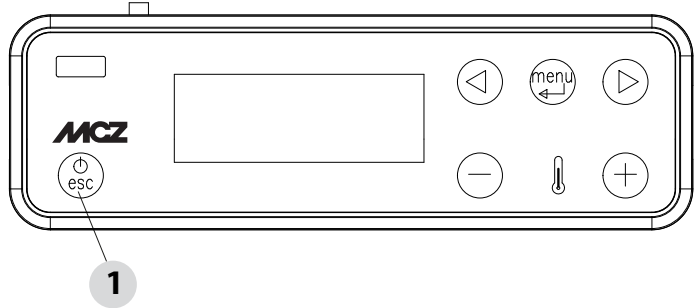
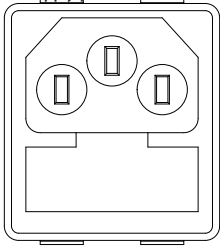

The default factory set room temperature is 20°C. To change this setting, follow the instructions in the adjustments menu. Do the same to set the heating water temperature and the speed of the room fan (if required). To activate an external thermostat, if present, see the dedicated paragraph.

### SWITCHING THE EQUIPMENT OFF

To switch the equipment off, press and hold the ON-OFF button on the remote control or on the APP. The acoustic beep confirms this phase has started.

Alternatively, switch it off from the emergency panel by following the instructions provided in the dedicated chapter

The equipment will start the shutdown process which involves consuming the residual pellets in the brazier, the latter being cleaned and the residual heat in the structure being disposed of.

During the disposal phase of the residual heat, the fans operate at about 80% of their output and the speed cannot be varied. This is determined by the need for all the accumulated heat to be evacuated safely and quickly. The switch-off phase can last 15 - 30 minutes

## 8-FIRST START-UP

depending on the heat stored in the structure, determined by the duration and the operating regime of the product throughout the day. When the internal temperature drops below the set thresholds, the fans for hot air and exhaust fume extraction will automatically switch off.

### POWER SUPPLY

When start-up is complete, the panel will display ON with a constant flame at level 3 . The modulation of the flame for higher or lower power is then controlled autonomously on the basis of reaching the set temperature. (see also "OPERATING MODE" - "Set Flame")

If the flame fails to ignite, despite a regular flow of pellets, check that the brazier is seated correctly: it must **rest snugly against the interlocking slot and be clean of any ash incrustations**. If no anomaly is found during this inspection, there may be a problem with the product components or installation may not be correct.



**REMOVE THE PELLETS FROM THE BRAZIER AND CONTACT AN AUTHORISED TECHNICIAN.**

*Please ensure the brazier is free from ALL pellets and ash build up following any failed ignitions. Failure to clear out the brazier prior to resetting may result in further failed ignitions or in certain conditions an explosive ignition.*



*It is good practice to ensure effective ventilation in the room during the initial start-up, as the product will emit some smoke and smell of paint.*

Do not stand close to the boiler and ventilate the room as described. The smell of paint will disappear after about an hour of operation, however, it is not harmful in any case.

The product will be subject to expansion and contraction during the start-up and cooling phases, therefore slight creaking noises may be heard.

This is absolutely normal as the structure is made of laminated steel and must not be considered a defect.



**DO NOT EXPECT HEATING EFFICIENCY IMMEDIATELY!!! THE PRODUCT NEEDS SOME RUNNING-IN TIME.**

It is extremely important to make sure the product does not reach high temperatures straight away, but to increase the temperature gradually using low power at first.

This will prevent damage to the welds and the steel structure.



**Do not touch the product during the first lighting, as it is during this phase that the paint sets. If you touch the paint, you may expose the steel surface.**

If necessary, touch up the paint with the spray can of the specific colour.

## 9-CONTROL PANEL

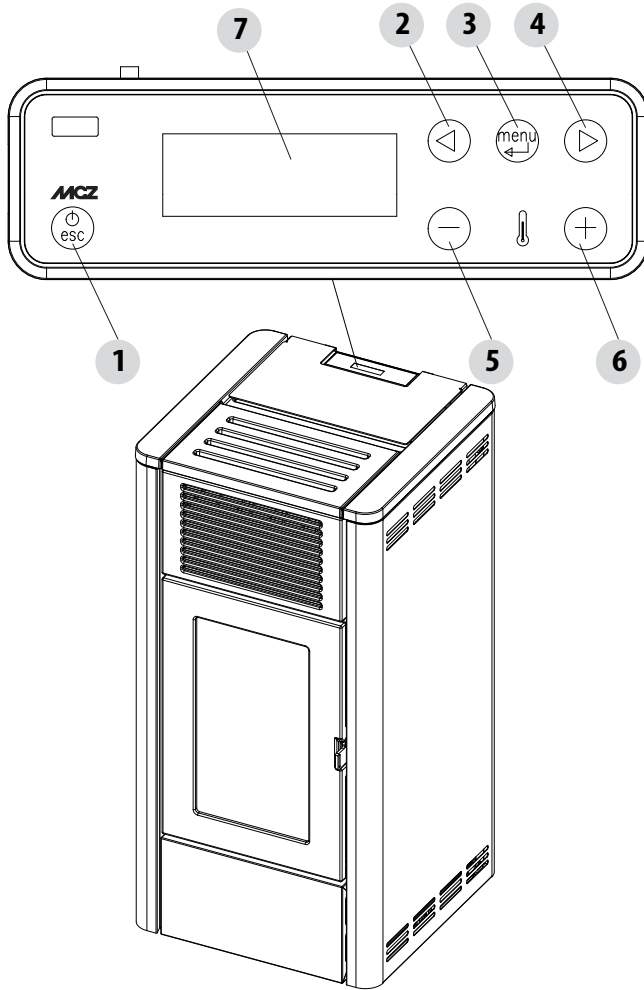

### KEY

- |  |  |
|--|--|
| 1. Stove switch-on/switch-off                  | 5. Decrease set temperature / programming functions. |
| 2. Scrolling down through the programming menu | 6. Increase set temperature / programming functions. |
| 3. Menu  | 7. Display.  |
| 4. Scrolling up the programming menu           |  |

## 10-MENU ITEMS AND OPERATION

### MAIN MENU

Press key 3 (menu) to access. The options accessed are:

- Date and Time
- Timer
- Sleep (only when stove is on)
- Settings
- Info

### Date and time configuration

Configure the time and date as follows:

- Press the “menu” key.
- Select “Date and Time”.
- Press “menu” to confirm.
- Scroll through with the arrow keys and select the variables to be edited one at a time: Day, Hour, Min, Num. day, Month, Year.
- Press “menu” to confirm
- Use the + and - keys to edit.
- Finally, press “menu” to confirm and “esc” to exit.

### CONFIGURATION OF PROGRAMMED MODE (TIMER) - Main menu



*The current time and date must be configured to ensure correct operation of the timer.*

There are six configurable TIMERS; for each one, the user can select a start and stop time and the days of the week when it is in use. When one or more programs are active, the status of the stove and the TIMER “n” alternate on the display. “n” is the number of timer programs in use, separated by dashes.

Example:

TIMER 1 Timer 1 program active.

TIMER 1-4 Timer 1 and 4 programs active.

TIMER 1-2-3-4-5-6 All timer programs active.

#### EXAMPLE OF PROGRAMMING

With the stove on or off:

- access the MENU,
- scroll to the TIMER item using the <> arrows,
- press the “Menu” key
- the system shows “P1” (Press the <> keys to move through the timers P2, P3, P4, P5, P6)
- Press the “Menu” key to activate “P1”.
- press + - and select “ON”
- press the “Menu” key to confirm

At this point the start time is 00:00. Press the + - key to set the start time and press the “menu” key to confirm.

Next, the proposed stop time is 10 minutes later than the configured start time: press the + key and edit the stop time, and press the “menu” key to confirm.

Next, you are asked to set the days of the week when the configured timer is to be enabled or disabled. Press the - or + keys to select the day you want to activate the time. It will light up white, then confirm with the “menu” key. If no day is selected for enabling the timer, the timer program is no longer enabled on the status window.

Next, program the other days or press “ESC” to exit. Repeat this procedure to program the other timers.

## 10-MENU ITEMS AND OPERATION

### EXAMPLES OF PROGRAMMING

P1			P2		
on	off	day	on	off	day
08:00	12:00	mon	11:00	14:00	mon
Stove on between 08:00 and 14:00					

P1			P2		
on	off	day	on	off	day
08:00	11:00	mon	11:00	14:00	mon
Stove on between 08:00 and 14:00					

P1			P2		
on	off	day	on	off	day
17:00	24:00	mon	00:00	06:00	tue
Stove on between 17:00 on Monday to 06:00 on Tuesday					

### NOTES ON USE OF THE TIMER

- The timer always starts the boiler with the last temperature and ventilation settings (or with the default settings at 20°C and V3 if they have never been altered).
- The start time can be between 00:00 and 23:50
- If the stop time has not yet been saved, the program proposes a start time at +10 minutes.
- If a timer program turns off the stove at 24:00 on one day and another program starts it up at 00:00 on the next day: the stove remains on.
- A program has a start-up and/or shut-down time that overlap the times of another program: if the stove is already on, the start has no effect while OFF turns off the stove.
- When the stove is on and the timer is active, pressing the OFF key turns off the stove; the stove then restarts automatically at the next time of the timer.
- When the stove is off and the timer is active, pressing the ON key turns on the stove; the stove then stops automatically at the next time of the timer.

### SLEEP FUNCTION (main menu)

Sleep may be activated only when the stove is on and allows you to quickly set a time for the product to turn off.

To set the Sleep function, proceed as follows:

- Enter the MENU
- Scroll to the SLEEP item with the <> arrows
- Press Menu
- Set the turn-off time you want using the + and - keys.

The panel shows a default time of 10 minutes after the current time, which can be adjusted with key 6 up to the following day (i.e. the turn-off can be delayed for a maximum of 23 hours and 50 minutes).

If the SLEEP function is active with the TIMER active, the former has priority, therefore the stove will not turn off at the time set in the timer program but at the time set by the sleep function, even if it comes after the time set by the timer.

## 10-MENU ITEMS AND OPERATION

### OPERATING MODE ADJUSTMENTS MENU

"Adjustments" menu settings determine the operation mode of the stove.

To access the menu, proceed as follows:

- Press the - + keys
- Scroll with the <> arrows and select "Set Amb. T" or "Set Ventilation T" or "Set Flame"
- Press "menu" to enter the option selected.
- Change with the + - keys.
- Press "menu" to confirm and "esc" to exit.

**Set Amb T** - this function is used to set the temperature to be reached in the room in which the stove is installed, from a minimum of 5°C to a maximum of 35°C. When this condition is met, the stove setting is equivalent to the minimum consumption values (the flame and hot air fan speed at minimum), and then returns to the set values when the room temperature drops below the set threshold.

PLEASE NOTE: The point to the right of the room temperature on the control panel display indicates the half degrees (e.g. 23.°C is equivalent to 23.5°C).

**Set Vent** - this function allows you to select the desired speed of the room fan from 1 to 5.

**Set Flame** - this function allows you to set the power of the flame from a minimum of 1 to a maximum of 5. The power levels correspond to a different value of fuel consumption, setting 5 heats the room in less time and setting 1 can keep the room temperature stable for a longer period of time. The set flame is automatically set to a minimum when the set temperature value is reached.

### VIEW WITH STOVE ON

if the bars are all full, the stove is on flame power 5

if only one bar is full, the stove is on flame power 1

if the bars are flashing, automatic cleaning is in progress

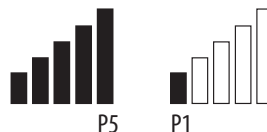



## 10-MENU ITEMS AND OPERATION

### SETTINGS MENU

The SETTINGS menu is to configure use of the stove:

- a. Language.
- b. Cleaning (shown only when stove is off).
- c. Auger loading (shown only when stove is off).
- d. Tones.
- e. External thermostat (activation).
- f. Auto Eco (activation).
- g. Eco Turn-off T (default 10 minutes).
- h. Pellet recipe.
- i. % of smoke rpm.
- j. Component test (shown only when stove is off).
- k. "Chimney sweeper" function (can be enabled only when stove is on to check emissions in field).
- l. Technical menu.

### a - Language

Select the language as follows:

- Press the "menu" key.
- Use the arrow keys to scroll through and select "Settings"
- Press "menu" to confirm.
- Use the arrow keys to scroll through and select "language".
- Press "menu" to confirm.
- Use the + - keys to select the required language (IT/EN/DE/FR/ES/NL/PL/DK/SLO)
- Press "menu" to confirm and "esc" to exit.

### b - Cleaning

Select "Cleaning" (only with stove off) as follows:

- Press the "menu" key.
- Use the arrow keys to scroll through and select "Settings"
- Press "menu" to confirm.
- Use the arrow keys to scroll through and select "Cleaning"
- Press "menu" to confirm.
- Use the + - keys to select "On".
- Press "esc" to exit.

### c - Load auger

To select "Load auger" (only with stove off), proceed as follows:

- Press the "menu" key.
- Use the arrow keys to scroll through and select "Settings"
- Press "menu" to confirm.
- Scroll with the arrows and select "Load auger".
- Press "menu" to confirm.
- With the + key "Enable" the load auger.
- Press "esc" to exit.

## 10-MENU ITEMS AND OPERATION

### d - Tones

This function is disabled by default. To enable it proceed as follows:

- Press the “menu” key.
- Use the arrow keys to scroll through and select “Settings”
- Press “menu” to confirm.
- Use the arrow keys to scroll through and select “Tones”
- Press “menu” to confirm.
- With the + - keys, select “On/Off”.
- Press “menu” to confirm and “esc” to exit.

### e - External thermostat (see dedicated chapter)

### f - Auto-Eco activation (see dedicated chapter)

To select the Auto-Eco function, proceed as follows:

- Press the “menu” key.
- Use the arrow keys to scroll through and select “Settings”
- Press “menu” to confirm.
- Scroll with the arrows and select “Auto-Eco”.
- Press “menu” to confirm.
- Use the + - keys to select “On”.
- Press “menu” to confirm and “esc” to exit.

### g - Eco stop T (see dedicated chapter)

To select the Eco Stop T function, proceed as follows:

- Press the “menu” key.
- Use the arrow keys to scroll through and select “Settings”
- Press “menu” to confirm.
- Scroll with the arrows and select “T Eco off”.
- Press “menu” to confirm.
- With the + - keys, insert the minutes (from 1 to 30’).
- Press “menu” to confirm and “esc” to exit.

### AUTO ECO MODE (see above paragraph activation and switching off)

For activation of the “Auto Eco” mode and time settings, see paragraphs 8 f and 8 g respectively.

“ECO stop T” can be adjusted to ensure correct operation in the various environments in which the stove can be installed and to avoid constant stopping and starting when the room temperature is subject to sudden change (drafts, poorly insulated rooms, etc.).

The ECO stop procedure is activated automatically when the power recall device is satisfied (room probe +1°C or external thermostat with an open contact), the “ECO stop T” starts to decrease the time (factory default 5 minutes, which can be changed from the “Settings” menu). During this phase, the panel alternates between displaying ON with a small flame and Crono (if active) - Eco active. The minutes counting down to the Eco Stop are shown at the top of the display. The flame moves to P1 and remains there until the set “T Eco Stop” time reaches zero, and if the conditions are still satisfied, turns off the boiler. The ECO stop count is cancelled if one of the devices recalls power. When the boiler begins to turn off, the panel shows: Off - Eco Active - flashing small flame.

When the stove turns off, OFF-ECO appears on the display with the flame symbol off.

The following conditions have to be met simultaneously for the ECO to restart:

- room probe -1°C or external thermostat with a closed contact (for at least 20” in order to prevent false recalls)
- 5 minutes have passed since shut-down.

## 10-MENU ITEMS AND OPERATION

### h - Pellet Recipe

This function is for adapting the stove to the type of pellet in use. As there are many types of pellet available on the market, operation of the stove can vary considerably according to the quality of the fuel. When the pellets clog up the brazier due to excess loading of fuel or when the flames are high even at low power, or when the flames are low, it is possible to decrease/increase the amount of pellets in the brazier:

Available values:

- 3 = A decrease of 20% on the factory setting.
- 2 = A decrease of 13% on the factory setting.
- 1 = A decrease of 6% on the factory setting.
- 0% No changes.
- 3 = An increase of 10% on the factory setting.
- 2 = An increase of 6% on the factory setting.
- 1 = An increase of 3% on the factory setting.

Edit the recipe as follows:

- Press the “menu” key.
- Use the arrow keys to scroll through and select “Settings”
- Press “menu” to confirm.
- Scroll with the arrows and select “Pellet recipe”
- Press “menu” to confirm.
- Alter the % with the + - keys.
- Press “menu” to confirm and “esc” to exit.

### i - Variation % rpm smoke

In the event the installation presents problems in extracting smoke (lack of draft or even pressure in the duct), it is possible to increase the smoke and ash extraction speed. This change resolves all the potential problems related to pellets clogging in the brazier and deposits forming at the bottom of the brazier itself caused by poor quality fuel or fuel that produces a lot of ash. The extraction speed may be altered between -30% to +50%, with increments of 10 percent at a time. Negative variation can be necessary if the flame is too low.

To alter this parameter, proceed as follows:

- Press the “menu” key.
- Use the arrow keys to scroll through and select “Settings”
- Press “menu” to confirm.
- Scroll with the arrows and select “Fumes rpm Var.”
- Press “menu” to confirm.
- Alter the % with the + - keys.
- Press “menu” to confirm and “esc” to exit.

### j - Components test

This can be done only when the stove is off and allows you to select the components to be tested:

- **Spark plug:** it is turned on for a fixed period of 1 minute during which the panel displays the countdown in seconds.
- **Feed screw:** it is powered for a fixed period of 1 minute during which the panel displays the countdown in seconds.
- **Extractor:** it is activated at 2500 rpm for a fixed period of 1 minute during which the panel displays the countdown in seconds.
- **Exchanger:** enables you to conduct the test in V5 for a fixed period of 1 minute during which the panel displays the countdown in seconds.

Enable the “Component test” function (only with stove off) as follows:

- Press the “menu” key.
- Use the arrow keys to scroll through and select “Settings”
- Press “menu” to confirm.

## 10-MENU ITEMS AND OPERATION

- Use the arrow keys to scroll through and select “Component test”
- Press “menu” to confirm.
- Use the + - keys to select the test to be carried out.
- Press “menu” to confirm and “esc” to exit.

### **k - Chimney sweeper function (for maintenance operators only) -**

This function can only be activated when the stove is on and power is supplied, and it forces operation of the boiler at the parameters P5, with the ventilator (if present) in V5. Any corrections to the loading/smoke ventilation percentage must be read. This state lasts 20 minutes, the countdown is displayed on the panel.

The technician can stop this phase at any moment by quickly pressing the on/off key.

Enable the “Chimney sweeper” function as follows:

- Press the “menu” key.
- Use the arrow keys to scroll through and select “Settings”
- Press “menu” to confirm.
- Use the arrow keys to scroll through and select “Chimney sweeper function”
- Press “menu” to confirm.
- Use the + - keys to select “On” (Off by default)
- Press “menu” to confirm and “esc” to exit.

### **l - Technical menu**

To access the technical menu you must contact the assistance centre as it requires a password.

Access the “technical menu” as follows:

- Press the “menu” key.
- Use the arrow keys to scroll through and select “Settings”
- Press “menu” to confirm.
- Use the arrow keys to scroll through and select “Technical menu”
- Press “menu” to confirm.
- With the + - keys, select “Product Type”, “Service”, “Counter memories”, “Parameters”.
- Press “menu” to confirm and “esc” to exit.

### **INFO MENU**

- Product type
- Firmware version
- Software info
- Total hours
- No. of start-ups
- Rpm evacuator
- T. smoke
- Heat exchanger voltage
- Feed screw loading
- Flame

## 10-MENU ITEMS AND OPERATION

### EXTERNAL THERMOSTAT CONNECTION (optional)



*The room thermostat is not included with the stove and must be installed by a qualified technician.*

**CAUTION!**

*The electrical wires must not come into contact with the hot parts of the stove.*

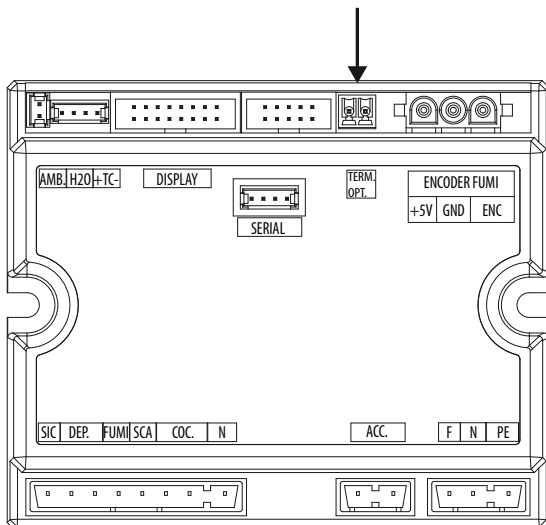

The temperature of the stove can also be controlled by an external room thermostat. It should be positioned centrally in the room where the stove is installed. It provides a closer match between the heating temperature requested of the stove and the actual room temperature it provides.

Connect the cables coming from the external thermostat to terminal "Term opt" on board N100 on the stove.

Enable the external thermostat (factory settings OFF) as follows:

- Press the "menu" key.
- Scroll with the arrows to "Settings".
- Press "menu" to select.
- Now use the arrows to scroll to "External thermostat".
- Press "menu" to select.
- Press the - + keys.
- Select "On" to activate the external thermostat.
- Press the "menu" key to confirm.
- Press the "esc" key to exit.

Once the external thermostat has been enabled, instead of displaying the detected temperature from the probe on the stove, ON or OFF will appear, depending on whether you have requested heat from the external thermostat or not.

**ON** if the external thermostat contact is closed, **OFF** if the contact is open.

## 10-MENU ITEMS AND OPERATION

### Remote control (accessory - NOT SUPPLIED)

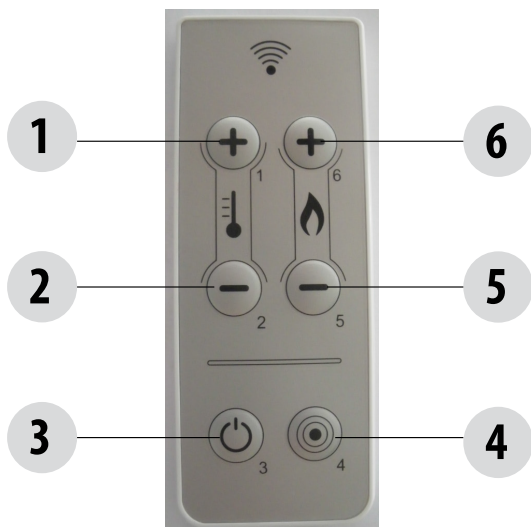

### LEGEND OF BUTTONS

1. Increase temperature set-point	4. Temperature/power switch and vice versa.
2. Decrease temperature set-point	5/6. Set power and ventilation
3. ON/OFF	
PLEASE NOTE Adjusting the temperature with the remote control has no effect if the external thermostat has been selected.	

Attention! Before using, remove the protection from the battery. The batteries are not included.

Keys 1 and 2: set the room temperature (automatic mode). See paragraph "Automatic mode".

Keys 6 and 5: set power and ventilation (manual mode). The values that can be set are from 1 to 5.

Power does not scale immediately but reaches it at the set time (1 power per minute)

Button 3: On/Off

Button 4: moves on from temperature to flame power; when passing from one status to another, the following values will be set:

- Temperature 23°C.

- Power 3 ventilation 3

### Batteries - type and replacement

The batteries are in the bottom of the remote control. To replace them, pull out the battery holder and remove or insert the battery in the orientation marked on the remote control and on the battery itself.

The remote control takes 1 CR2025 lithium battery.



**Used batteries contain metals which are harmful to the environment, so they must be disposed of separately in appropriate containers.**



**If the remote control is off because it has no battery, the stove can be controlled with its top-mounted control panel. While replacing the battery, observe the orientation marked inside the battery compartment**

## 11-SAFETY DEVICES

### SAFETY DEVICES

The product is fitted with the following safety devices

#### PRESSURE SWITCH

Monitors pressure in the smoke duct. It is designed to shut down the pellet feed screw in the event of an obstructed flue or significant back-pressure (from the wind).

#### SMOKE TEMPERATURE PROBE

Detects the temperature of the smoke, thereby enabling start-up or stopping the product when the temperature drops below the preset value.

#### CONTACT THERMOSTAT IN THE FUEL TANK

If the temperature exceeds the preset safety level, it immediately shuts down the running of the stove.

#### ELECTRICAL SAFETY

The stove is protected against violent changes in current by a general fuse located in the control panel at the back of the stove. Other fuses that protect the electronic boards are found on the latter.

#### SMOKE FAN

If the fan stops, the electronic board shuts off the supply of pellets in good time, and an alarm message is displayed.

#### GEAR MOTOR

If the reduction motor stops, the stove will continue to run until the flame goes out due to lack of fuel and until a minimum level of cooling is reached.

#### TEMPORARY POWER CUT

When a power cut is less than 10" the stove returns to its previous operating state; if it is more, it executes a cooling/re-ignition cycle.

#### FAILED START-UP

If during ignition no flame develops, the stove will go into alarm condition.

#### **TAMPERING WITH THE SAFETY DEVICES IS PROHIBITED**

***If the product is NOT used as described in this instruction manual, the manufacturer declines all liability for any damage caused to persons and property. The manufacturer furthermore refuses to accept responsibility for damage to persons and property arising from the failure to observe all the rules contained in the manual and in particular:***

- ***All the necessary measures and/or precautions must be adopted when performing maintenance, cleaning and repairs.***
- ***Do not tamper with the safety devices.***
- ***Do not remove the safety devices.***
- ***Connect the product to an efficient smoke expulsion system.***
- ***First, check that the environment where it is to be installed is properly ventilated.***

***Only after having eliminated the cause of the intervention of the safety system is it possible to relight the product and therefore restore the automatic operation of the probe. This manual will help you understand which anomaly has occurred, and explain how to intervene according to the alarm message displayed on the appliance.***

## 12-ALARMS

### ALARM SIGNALLING

When a condition occurs other than the one expected for regular operation of the stove, an alarm is triggered.

The reason for the alarm is given on the control panel. The sound signal is not enabled for alarms A01-A02 in order not to disturb the user when there is an absence of pellets in the night tank.

Panel signalling	type of problem	Solution
<b>A01</b>	The flame does not light	Check the level of pellets in the tank. Check that the brazier is correctly positioned in its seat and has no build-up or unburned material. Make sure the ignition plug warms up. Thoroughly empty and clean the brazier before restarting.
<b>A02</b>	The fire goes out abnormally.	Check the level of pellets in the tank.
<b>A03</b> Thermostat alarm	The temperature of the pellet hopper exceeds the required safety threshold.	Wait until the end of the cooling phase, stop the alarm and re-ignite the stove setting the supply of fuel to minimum (SETTINGS menu - pellet recipe). If the alarm persists, contact the service centre. Check whether the room fan is working correctly.
<b>A04</b>	Smoke overtemperature	Reduce the load of pellets (SETTINGS menu - Pellet recipe); check cleaning of the brazier.
<b>A05</b> Safety devices alarm	Smoke pressure switch intervention	Check for chimney obstructions / door open
	Fuel loading hatch	Close the hatch. Lower the fuel level in the tank.
	Open stove door	Close the door
<b>A08</b>	Anomalous operation of smoke fan.	Delete the alarm and switch the stove on again. If the alarm persists, contact the service centre.
<b>A09</b>	Fault with the smoke sensor.	Delete the alarm and switch the stove on again. If the alarm persists, contact the service centre.
<b>Service</b>	Routine maintenance warning (does not seize)	When this blinking message appears upon start-up, it means it is time to carry out scheduled maintenance. Call the assistance centre.

### ALARM RESET

To reset the alarm, press and hold key 1 (ESC) for a few seconds. The stove checks whether the cause of the alarm is ongoing.

In the first case, the alarm continues to be displayed, in the second case it turns OFF.

If the alarm persists, contact a service centre.



## 12-ALARMS

### **NORMAL SHUTDOWN (on the panel: OFF with flashing flame symbol)**

When the shutdown key is pressed, or when there is an alarm signal, the stove enters the thermal extinguishing phase which involves automatic execution of the following phases.

- Stop pellet loading
- The room fan maintains the set speed until reaching the switch-off temperature
- The smoke extractor fan is activated at maximum speed and remains on for a fixed period of 10 minutes, at the end of which if the smoke T has dropped below the stop threshold, the fan stops, otherwise it will continue to operate at minimum speed until the temperature drops below the threshold.
- If the stove has been shutdown regularly but, due to thermal inertia, the smoke temperature exceeds the threshold again, the shutdown phase will be repeated at minimum speed until the temperature drops.

### **BLACKOUT WITH STOVE ON**

In the event of a blackout, the stove does the following:

- Blackout of less than 10": continues the work in progress;
- After a loss of power of more than 10" which occurred when the stove was on, or during ignition, you can restore the stove to its previous operating condition when power returns as follows:
  1. Cool the boiler by activating the smoke extractor at minimum speed for 10' then proceed to the next step;
  2. Restore the stove to the operating condition prior to the blackout.

During phase 1, the panel shows ON BLACK OUT.

During phase 2, the panel shows Start-up.

If during phase 1 the stove receives manual user commands from the control panel, it stops the blackout restoration sequence and begins the start-up or shutdown commanded by the user.

### **BLACKOUT OF MORE THAN 10" DURING EXTINCTION OF STOVE**

If the stove experiences a loss of power GREATER THAN 10" while it is shutting down, when power is restored to the stove, it will automatically turn on in shutdown mode, even if the smoke temperature has fallen below 45°C in the meantime. This phase can be skipped by pressing key 1 (esc) (skips to start-up) and pressing it again (recognises that the stove is off).

### **BLACKOUT OF MORE THAN 10" WITH THE STOVE OFF FROM ECOSTOP**

Once power has been restored, a 5-minute timer is set as though the stove were in switch-off mode; should there be a request for heat in these 5 minutes, the stove will not start.

### **SAFETY DEVICES ALARM A05**

The safety devices alarm includes the intervention of the smoke pressure switch, of the fuel loading hatch and of the open stove door. The alarm will be triggered after 30 seconds, after which the stove will stop working (e.g. after 30 seconds with the pellet loading hatch open, alarm A05 will be triggered).

## 12-ALARMS

In the event that alarm A05 is triggered often, please note that:

<b>A05</b>  <b>Safety devices alarm</b>	Smoke pressure switch intervention	Check for chimney obstructions / door open
	Fuel loading hatch	Close the hatch. Lower the fuel level in the tank.
	Open stove door	Close the door

you must check some points to verify the cause of the problem and possibly act on some adjustments and/or safety devices to restore the correct operation of the product.

However please note that all the adjustments and alterations affecting the operational safety devices, must only be performed if THE PRODUCT IS INSTALLED IN COMPLIANCE WITH THE STANDARDS AND LAWS IN FORCE AND IF IT IS SERVICED PROPERLY BY AUTHORISED AND SPECIALISED PERSONNEL. Alterations performed randomly, to ensure operation of the product even in the non-compliant conditions, can cause serious damage to property and injuries to people. If this occurs, the manufacturer declines all liability



### **Attention!**

***The adjustments should only be performed by authorised and qualified personnel and upon verification of the installation compliance. The manufacturer declines all liability for damage to property or injuries to people in the event of altering the safety devices.***

As mentioned alarm A05 identifies a drop in pressure inside the product that can be generated by difficulty to discharge the fumes (ash clogging the flue), to draw combustion air (clogged ducting or no air inlet) or by opening some stove compartments (fire door or pellet tank cover)

In light of the above, before acting on the safety devices or on any adjustments, you must check in this sequence if there are any potential malfunctions that may generate the alarm. Therefore check that:

- The stove door is closed
- The pellet loading hatch is closed
- The installation is compliant and the flue/smoke fitting does not generate obvious obstructions which can stop the release of smoke, such as: long horizontal sections (over 3 metres), uninsulated smoke ducts, "wall-mounted" smoke exhaust without proper terminals (installation regulated and permitted in France only [ZONE 3])
- The minimum depression in the flue is at least 5 Pa
- The pellets are of certified quality and do not cause obstructions
- There is no ash clogging the flue and the latter is serviced properly.
- There are no foreign bodies in the flue (nests, birds, grilles, leaves etc..)
- There are no foreign bodies in the combustion air ducting and/or in the room air inlet
- When installed without combustion air ducting, it is crucial to check that there is an efficient air inlet dedicated to the stove, according to the specifications referred to in chapter 2 of this manual.
- That there are no internal air extraction or recirculation systems (e.g. VMC systems) that generate internal depressions exceeding those required by law (not exceeding 4 Pa)
- That the pressure switch is not damaged or dirty (inspection to be performed by an authorised service centre)
- That the stove gasket (fire door, pellet tank, etc..) is not worn or damaged. Otherwise contact an authorised service centre for replacement/repair



### **Attention!**

***All liability for improper use of the product is entirely borne by the user and relieves the Manufacturer from any civil and criminal liability.***

## 12-ALARMS

If all the above checks are negative, it is likely that the depression inside the stove drops due to poor performance of the flue, especially when the machine is operating at minimum speed for a long time.

In this case it is possible to make small adjustments that allow you to increase the operating speed of the smoke fan to increase the depression inside the product, or make it less sensitive to the intervention of the pressure switch by changing its position mechanically. While the first adjustment has no impact on the level of safety, the second one described affects it considerably and therefore should only be performed by authorised and specialised personnel after carrying out all the inspections mentioned above.

### Changing the smoke fan revolutions

In the event the installation presents problems in extracting smoke (lack of draft or even pressure in the duct), it is possible to increase the smoke and ash extraction speed. This change resolves all the potential problems related to pellets clogging in the brazier and deposits forming at the bottom of the brazier itself caused by poor quality fuel or fuel that produces a lot of ash. The extraction speed may be altered between -30% to +50%, with increments of 10 percent at a time. Negative variation can be necessary if the flame is too low.

To alter this parameter, proceed as follows:

- Press the “menu” key.
- Use the arrow keys to scroll through and select “Settings”
- Press “menu” to confirm.
- Scroll with the arrows and select “Fumes rpm Var.”
- Press “menu” to confirm.
- Alter the % with the + - keys.
- Press “menu” to confirm and “esc” to exit.

## 13-RECOMMENDATIONS FOR SAFE USE



**ONLY CORRECT INSTALLATION AND APPROPRIATE MAINTENANCE AND CLEANING OF THE APPLIANCE CAN GUARANTEE CORRECT OPERATION AND SAFE USE OF THE PRODUCT.**

We would like to inform you that we are aware of cases of malfunctioning of domestic pellet-fuelled heating products, mainly due to incorrect installation and use, as well as inadequate maintenance.

We would like to assure you that all of our products are extremely safe and certified according to European standards of reference. The ignition system has been tested with the utmost attention to enhance ignition efficiency and to prevent any type of problem, even in the worst operating conditions. In any case, like for any other pellet-fuelled product, our appliances must be installed correctly and undergo regular periodical cleaning and maintenance to guarantee safe operation. Our studies show us that malfunctioning is mainly due to the combination of part or all of the following factors:

- Brazier holes obstructed or brazier deformed, due to lack of maintenance and conditions which can cause delayed ignitions, generating an anomalous production of unburned gases.
- Insufficient combustion air due to a reduced or clogged air inlet duct.
- Use of smoke ducts nonconforming to regulatory installation requirements, failing to guarantee an adequate draught.
- Partially clogged chimney, due to lack of maintenance, reducing the draught and making ignition difficult.
- End chimney pot nonconforming to the indications of the instruction manual, and therefore not suitable to prevent potential inverse draught.
- This factor is crucial when the product is installed in especially windy areas, such as coastal regions.

The combination of one or more of these factors could generate important malfunctioning conditions.

To keep this from occurring, it is fundamental to guarantee that the product is installed in compliance with standards in force.

Furthermore it is of the utmost importance to respect the following simple rules:

- Every time the brazier is removed for cleaning, it must always be put back properly in the work position before using the product, completely removing any residual filth left on the support base.
- Pellets must never be loaded in the brazier manually, either before ignition or during operation.
- The accumulation of unburned pellets ensuing a failed ignition must be removed before repeating ignition. Also check that they are fed correctly and that the combustion air inlet/smoke outlet are regular.
- If ignition fails repeatedly, immediately suspend use of the product and contact a qualified technician to check its operation.

Compliance with these indications is absolutely sufficient to guarantee proper operation and to avoid any type of problems with the product.

If the above-mentioned precautions are not taken, and during ignition the brazier is overloaded with pellets thus generating anomalous smoke in the combustion chamber, carefully follow the indications below:

- Do not disconnect electrical power to the product for any reason whatsoever: this would stop the smoke extractor, releasing smoke into the environment.
- Take the precaution of opening the windows to ventilate the installation room from any smoke in the environment (the chimney might not work properly).
- Do not open the fire door: this would compromise regular operation of the smoke extraction system to the chimney.
- Just switch the stove off by acting on the on-off button on the control panel (not the rear power supply socket button!) and move away until smoke has completely evacuated.
- Before attempting re-ignition, clean the brazier and its air passage holes completely of all deposits and unburned pellets. Put the brazier back in place, removing any residue from its support base. If ignition fails repeatedly, immediately suspend use of the product and contact a qualified technician to check its operation and the chimney.

## 14-CLEANING

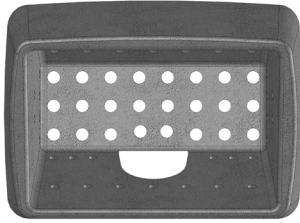

EXAMPLE OF A CLEAN BRAZIER



EXAMPLE OF A DIRTY BRAZIER

Only by properly servicing and cleaning the product is it possible to ensure its safety and correct operation.



### **ATTENTION!**

**All the cleaning operations of all parts must be performed with the product completely cold and the plug disconnected.**

**Disconnect the product from the 230V power supply before performing any maintenance operation.**

The product requires little maintenance if used with certified good quality pellets.

## DAILY OR WEEKLY CLEANING PERFORMED BY THE USER

### Brazier cleaning

Before ignition, always clean the “b” brazier and remove any ash or incrustation from it that might obstruct the air flow holes, paying attention to hot ash. In the case of ignition failure, or if fuel in the tank runs out, unburned pellets may accumulate in the brazier. Always empty the residue in the brazier before each start-up. Only if ash is completely cold may a vacuum cleaner be used to remove it. In this case, use a suitable vacuum cleaner to remove small sized particles.



**REMEMBER THAT ONLY A CORRECTLY POSITIONED AND CLEAN BRAZIER CAN GUARANTEE IGNITION AND OPTIMAL OPERATION OF YOUR PELLET PRODUCT. IN CASE OF FAILED IGNITION AND AFTER ANY OTHER LOCK STATE OF THE PRODUCT, IT IS ESSENTIAL TO EMPTY THE BRAZIER BEFORE EVERY RESTART.**

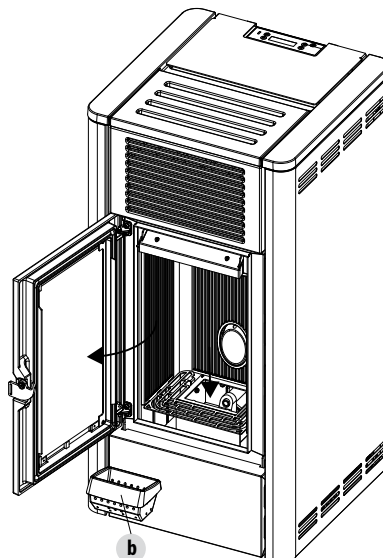

## 14-CLEANING

For the brazier to be cleaned properly, remove it from its housing completely and thoroughly clean all the holes and the grate on the bottom. If good quality pellets are used, you will normally only need to use a brush to restore the optimal operating conditions of the component.

### Cleaning the ash collection compartment

To clean the ash collection compartment, you must raise grille "g" by rotating until it rests against the hearth. Clean out any residual ash before lowering the grille "g". The quality of the pellets used and user experience will determine the required cleaning frequency. **However, it is recommended not to exceed 2 or 3 days.**

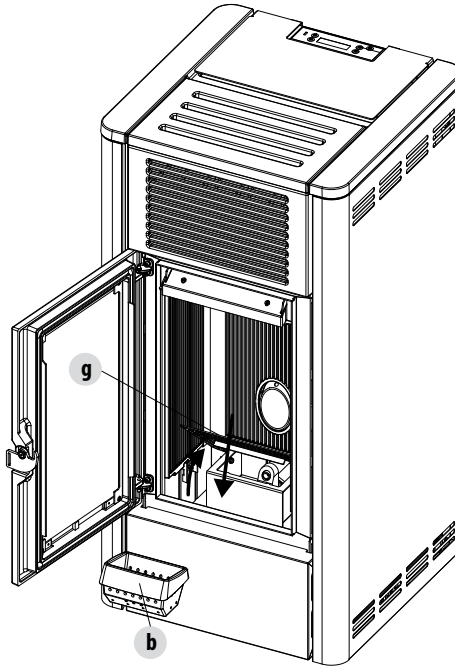

### CLEANING THE GLASS

It is recommended to clean the ceramic glass with a dry brush, or if it is very dirty, spray a little specific detergent and clean with a cloth.



#### **ATTENTION!**

*Do not use abrasive products and do not spray the glass cleaning product on the painted parts and on the door gaskets (ceramic fibre cord).*

## 14-CLEANING

### PERIODIC CLEANING PERFORMED BY A QUALIFIED TECHNICIAN CLEANING THE HEAT EXCHANGER

Half-way through the winter season, **but especially at the end**, the compartment through which the exhaust smoke passes will need to be cleaned. This cleaning process is mandatory in order to facilitate the general removal of all combustion residue, before it becomes very difficult to remove it due to the humidity compacting it over time.



#### ATTENTION:

*It is obligatory to have an authorised and skilled technician perform the periodic end-of-season cleaning in order to replace any worn gaskets.*

### CLEANING THE LOWER COMPARTMENT

To clean ash out of the lower compartment, open the pellet loading access door "B", remove the top "A", the side panels "C" and "D", and the lower front panel "F". Now loosen the four screws "y", remove the plate "n" and gasket "o"; use the nozzle of a vacuum cleaner to remove any ash and soot that may have built up in the lower exchanger indicated by the arrow. Before restoring cap "n" we recommend changing the gasket "o".

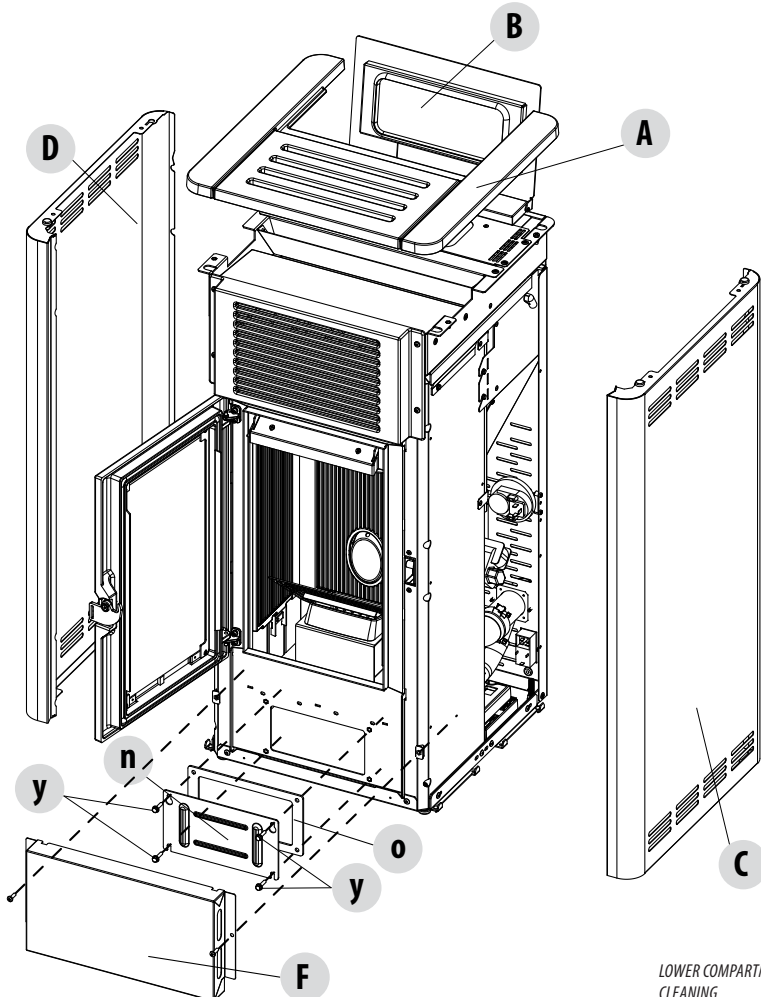

LOWER COMPARTMENT  
CLEANING

## 14-CLEANING

### CLEANING THE EXCHANGER

#### CLEANING THE UPPER COMPARTMENT

Clean the upper exchanger when the stove is cold and without cladding. After removing the cap for lower cleaning "N" (see previous paragraph), use a stiff rod or a bottle brush to scrape the firebox walls (see arrow) so that the ash falls into the lower compartment.

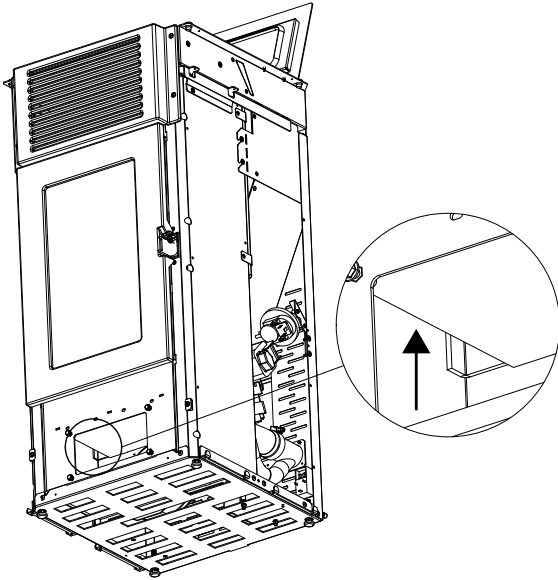

Then remove the upper Calorite plate "H"; to do this, open the firebox door and lift the Calorite plate "H" by tilting it right or left so that it comes out of its supports and remove it.

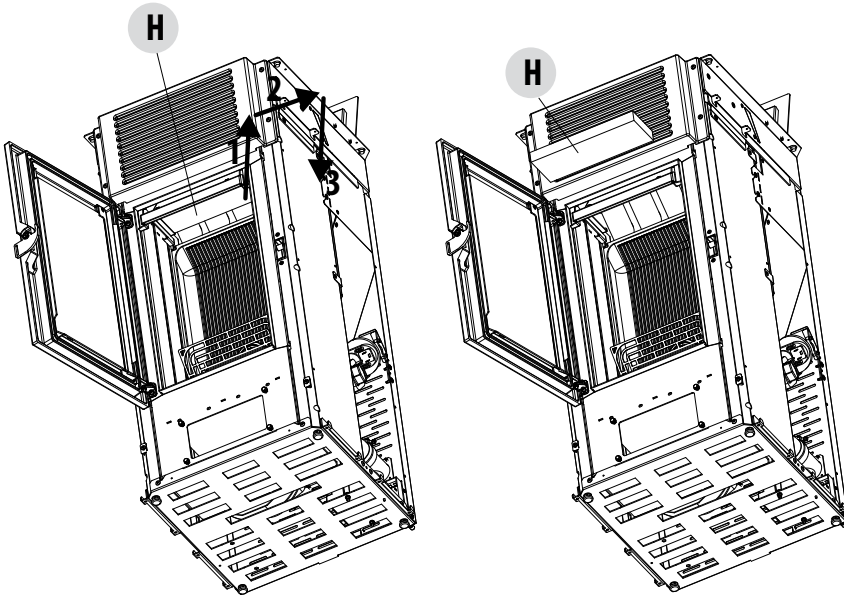



## 14-CLEANING

Use a stiff rod or a bottle brush to scrape the firebox walls (see arrow - at the right and left of the firebox respectively) so that the ash falls into the lower compartment.

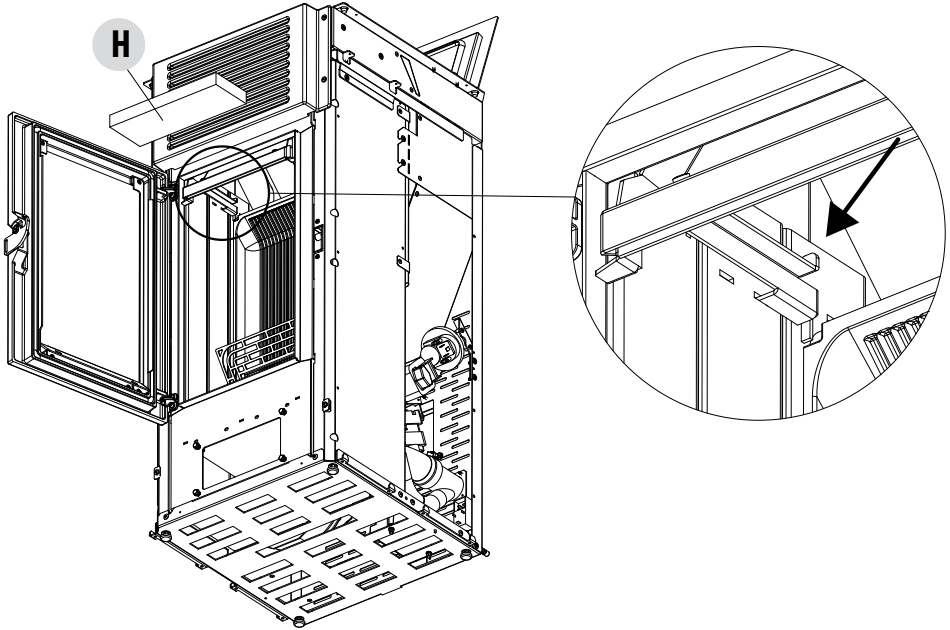

Use a vacuum cleaner nozzle to vacuum up any remaining ash and dust on the exchanger (see arrow).

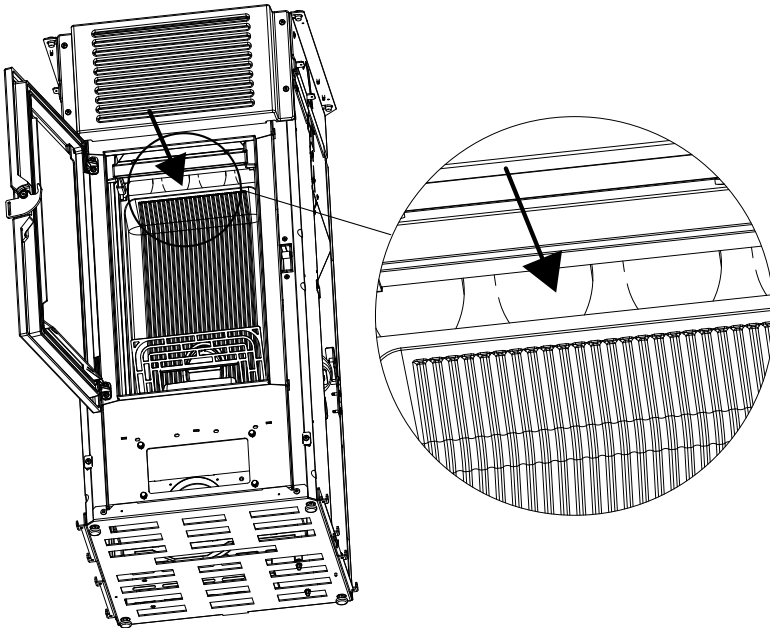

## 14-CLEANING

In the upper section, too, remove the front panel "E" (see the instructions in the dedicated paragraphs) and insert the nozzle of the vacuum cleaner to remove any deposits of dust.  
Then thoroughly clean the lower exchanger, replace any gaskets if needed, and reassemble.

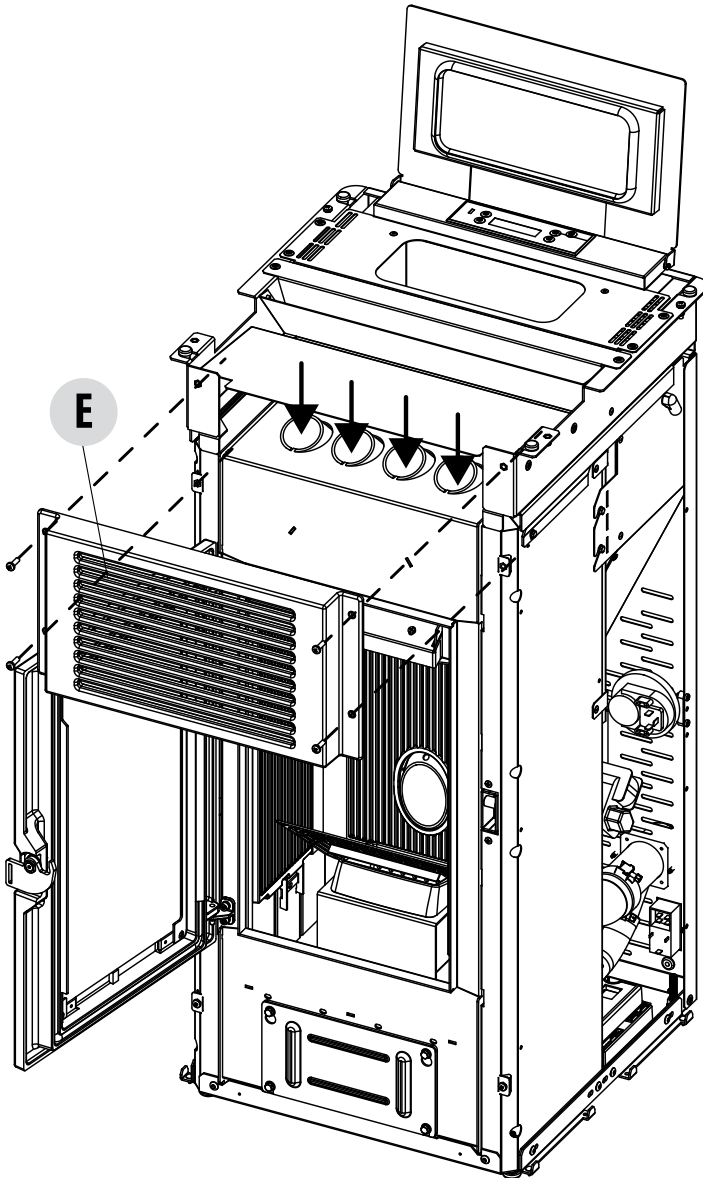

## 14-CLEANING

### CLEANING THE SMOKE DUCT AND GENERAL CHECKS

Clean the smoke extractor system, especially around the "T" joints, elbows and any horizontal sections of the smoke duct. For information on periodically cleaning the flue, contact a skilled chimney sweep.

Check the seal of the ceramic fibre gaskets on the door of the stove. If necessary, order new replacement gaskets from the retailer or contact an authorised service centre to carry out the operation.



#### ATTENTION:

*The frequency with which the smoke outlet system is cleaned depends on the use of the boiler and the type of installation.*

*We recommend relying on an authorised service centre for end-of-season cleaning and maintenance, as they will carry out all of the previously mentioned work and inspect the stove components.*

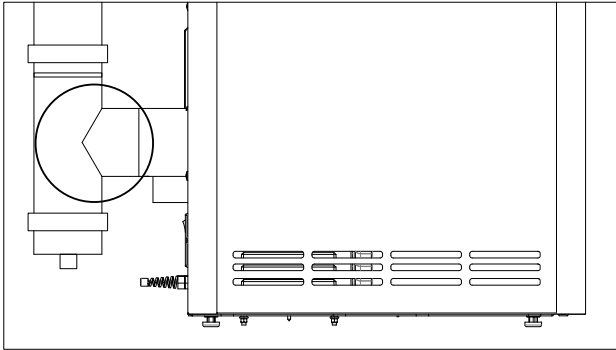

"T" FITTING

### PERIODICAL CHECK OF THE DOOR CLOSURE

Make sure the door closure ensures a correct sealing action (with the "paper sheet" test) and that when the door is closed, the closing block (X in the figure) does not protrude from the sheet metal to which it is secured. For some products it will be necessary to disassemble the cladding to be able to assess the anomalous protrusion of the block when the door is closed.

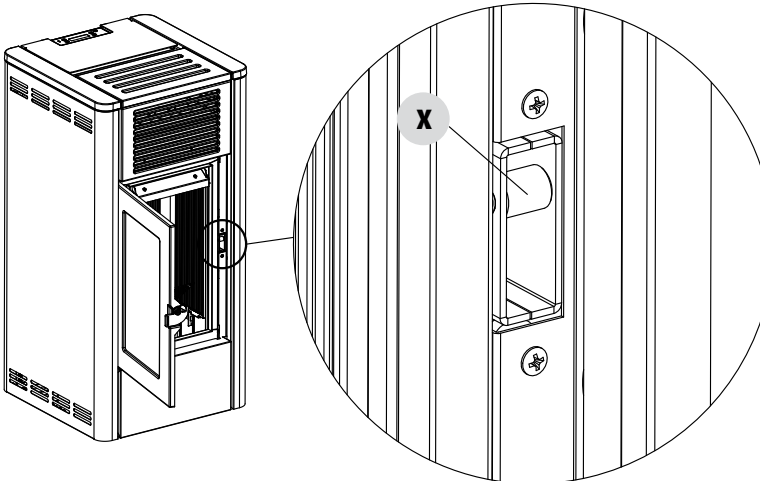

## 14-CLEANING

### SHUTDOWN (end of season)

At the end of each season, before switching the product off, it is recommended to remove all the pellets from the tank with a vacuum cleaner with a long pipe.

We recommend removing the unused pellet from the tank because it can retain humidity. Disconnect any combustion air ducting that can lead humidity inside the combustion chamber but, above all, ask the specialised technician to refresh the paint inside the combustion chamber with the special silicone spray paints (available at any store or CAT) during the necessary annual end of season scheduled maintenance operations. In this way the paint will protect the inner parts of the combustion chamber, blocking any type of oxidative process.

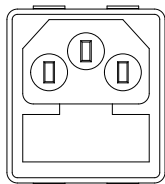

**When not in use the appliance must be disconnected from the mains power supply. It is recommended to remove the power cable for additional safety, especially in the presence of children.**

The service fuse may have to be replaced if the control panel display does not switch on when the product is switched on again by pressing the main switch on its side.

There is a fusebox on the side of the product, near the power socket. Open the fusebox cover with a screwdriver and replace the fuses if necessary (3.15 A delayed) - seek assistance from an authorised and qualified technician.

### CHECKING THE INTERNAL COMPONENTS



#### **ATTENTION!**

***The internal electromechanical components must only be checked by qualified personnel whose technical expertise includes combustion and electricity.***

We recommend that an annual maintenance service is carried out (with a scheduled service contract). This service is essentially a visual and functional inspection of the internal components. The following is a summary of the checks and/or maintenance that are essential for the correct operation of the product.

PARTS/INTERVAL	1 DAY	2-3 DAYS	1 YEAR
Brazier	•		
Ash compartment		•	
Glass		•	
Lower exchanger			•
Complete exchanger			•
Smoke duct			•
Door gasket			•
Remote control battery (if purchased/optional)			•
Door closure operation			•

## 15-TROUBLESHOOTING



### ATTENTION!

All repairs must only be carried out by a specialised technician, with the product switched off and the plug disconnected.

ANOMALY	POSSIBLE CAUSES	SOLUTIONS
<b>The pellets are not fed into the combustion chamber.</b>	The pellet hopper is empty	Fill the hopper with pellets.
	Sawdust has blocked the feed screw	Empty the hopper and remove the sawdust from the feed screw by hand.
	Faulty gear motor	<i>Replace the gear motor.</i>
	Faulty electronic board	<i>Replace the circuit board.</i>
<b>The fire goes out or the boiler stops automatically.</b>	The pellet hopper is empty	Fill the hopper with pellets.
	The pellets are not fed	See the previous anomaly.
	The pellet temperature safety probe has been triggered	Let the product cool down, restore the thermostat until the lockout is off and switch the product back on. If the problem persists, contact Technical Assistance.
	The door is not closed properly or the gaskets are worn	<i>Close the door and replace the gaskets with original ones.</i>
	Unsuitable pellets	Change the type of pellets with those recommended by the manufacturer.
	Low pellet supply	<i>Check the flow of fuel following the instructions in the manual.</i>
	The combustion chamber is dirty	Clean the combustion chamber, following the instructions in the manual.
	Clogged outlet	Clean the smoke duct.
	Faulty smoke extraction motor	<i>Check the motor and replace it, if necessary.</i>
	Pressure switch broken or defective.	<i>Replace the pressure switch.</i>
<b>The product works for a few minutes and then switches off.</b>	Start-up phase is not completed	Repeat start-up.
	Temporary power cut	Wait for the automatic restart.
	Clogged smoke duct	Clean the smoke duct.
	Faulty or malfunctioning temperature probes	<i>Check and replace the probes.</i>
	Faulty spark plug	<i>Check the spark plug and replace it, if necessary.</i>

## 15-TROUBLESHOOTING

ANOMALY	POSSIBLE CAUSES	SOLUTIONS
<b>Pellets accumulate in the brazier, the glass of the door gets dirty and the flame is weak.</b>	Insufficient combustion air.	Clean the brazier and check that all the holes are clear. Perform a general cleaning of the combustion chamber and the smoke duct. Check that the entry of air is not obstructed.
	Damp or unsuitable pellets.	Change the type of pellets.
	Faulty smoke evacuation motor.	<i>Check the motor and replace it, if necessary.</i>
<b>The smoke evacuation motor does not work.</b>	No electrical supply to the stove.	Check the mains voltage and the protection fuse.
	The motor is faulty.	<i>Check the motor and capacitor and replace them, if necessary.</i>
	Defective motherboard.	<i>Replace the electronic board.</i>
	The control panel is broken.	<i>Replace the control panel.</i>
<b>The convection air fan never stops.</b>	Faulty or malfunctioning temperature control probe.	<i>Check the probe and replace it, if necessary.</i>
<b>In the automatic position, the stove always runs at full power.</b>	Thermostat is set to minimum.	Reset the temperature of the thermostat.
	The room thermostat is in the maximum position.	Reset the temperature of the thermostat.
	Malfunctioning temperature probe.	<i>Check the probe and replace it if necessary.</i>
	Faulty or malfunctioning control panel.	<i>Check the panel and replace it, if necessary.</i>
<b>The product does not start.</b>	No power supply.	Check that the plug is inserted and the main switch is in the "I" position.
	Pellet sensor has seized up.	Check the recipe parameters.
	Blown fuse.	Replace the fuse.
	Pressure switch broken (lockout indicated).	Insufficient pressure of water in stove.
	Clogged smoke outlet or smoke duct.	Clean the smoke exhaust and/or the smoke duct.
<b>Noisy air fan even though it is set to minimum</b>	High set flame causes ventilation increase	Lower set flame from Adjustments menu

## 15-TROUBLESHOOTING

ANOMALY	POSSIBLE CAUSES	SOLUTIONS
<b>No increase in temperature with stove in operation.</b>	Incorrect combustion adjustment.	Check recipe.
	Set flame 1 setting (level too low)	Increase power from the settings menu.
	Poor pellet quality.	Using pellets from the producer.

## 16-CIRCUIT BOARD

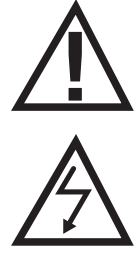
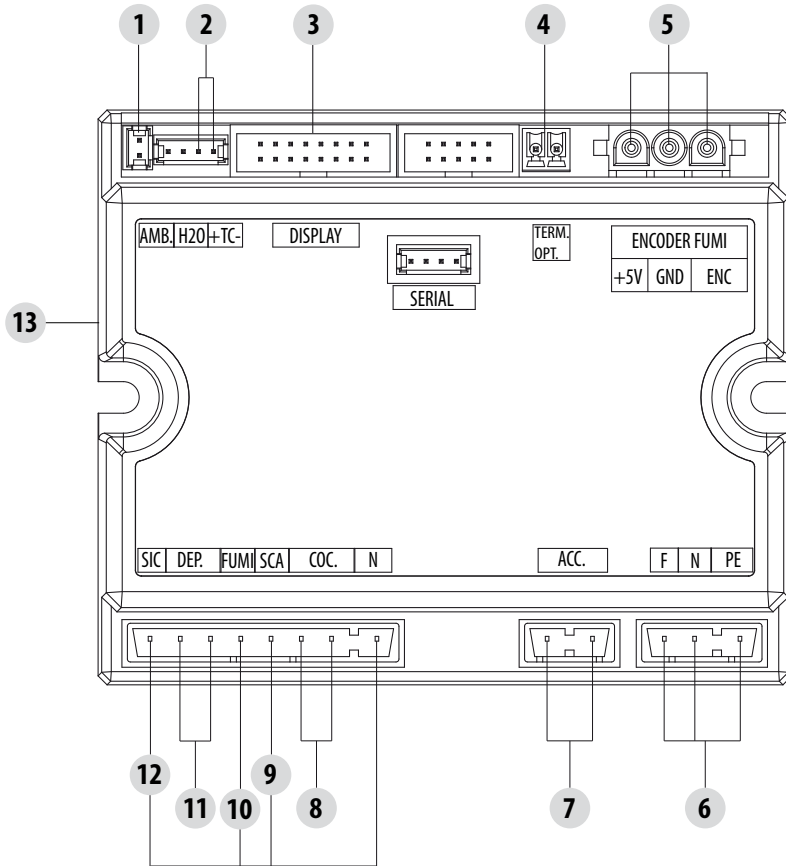

LIVE ELECTRICAL CABLES

DISCONNECT THE POWER SUPPLY CABLE 230V BEFORE CARRYING OUT ANY OPERATIONS ON THE ELECTRICAL BOARDS

### WIRING KEY

- |                                   |   |
|-----------------------------------|---|
| 1. ROOM PROBE                     | 8. FEED SCREW   |
| 2. SMOKE PROBE                    | 9. ROOM FAN   |
| 3. CONTROL PANEL                  | 10. SMOKE FAN   |
| 4. EXTERNAL THERMOSTAT (OPTIONAL) | 11. AIR PRESSURE SWITCH/DOOR SWITCH/SWITCH PELLET LOADING HATCH |
| 5. SMOKE ENCODER                  | 12. PELLET SAFETY THERMOSTAT                                    |
| 6. POWER SUPPLY                   | 13. WI-FI   |
| 7. GLOW PLUG                      |   |

**PLEASE NOTE** The electrical wiring of individual components is fitted with pre-wired connectors of different sizes.











Via La Croce n°8  
33074 Vigonovo di Fontanafredda (PN) – ITALY  
Telephone: +39 0434/599599 r.a.  
Fax: +39 0434/599598  
Internet: [www.mcz.it](http://www.mcz.it)  
e-mail: [info.red@mcz.it](mailto:info.red@mcz.it)