



PELLET STOVE

# THEA HYDRO 16 S1 THEA HYDRO 23 S1

**PART 1 - REGULATIONS AND ASSEMBLY**

Instructions in English

The logo for MCZ, consisting of the letters 'MCZ' in a bold, stylized, black font.

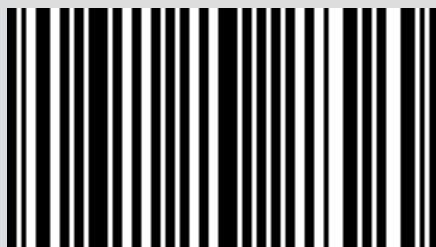

8902009100

## TABLE OF CONTENTS

TABLE OF CONTENTS .....	II
INTRODUCTION .....	1
1-WARNINGS AND WARRANTY CONDITIONS .....	2
2-INSTALLATION .....	9
3-DRAWINGS AND TECHNICAL SPECIFICATIONS .....	18
4-UNPACKING.....	21
5 - SMOKE OUTLET CONNECTION .....	24
6-ASSEMBLING METAL STOVE SIDES.....	27
7-REMOVAL OF CLADDINGS .....	31
8-OPENING THE DOORS .....	34
9-EASY CONNECT ACCESSORY .....	36
10-LOADING THE PELLETS .....	37
11 HYDRAULIC CONNECTION.....	38
12-ELECTRICAL CONNECTION.....	43

## INTRODUCTION

Dear Customer,

Our products are designed and manufactured in accordance with standards in force, with high quality materials and using our extensive experience in the transformation processes.

To get the best performance, we suggest you read the instructions in this manual carefully.

This installation guide is an integral part of the product: ensure that the manual is always supplied with the appliance, even if it changes owner. If the manual is lost, you can request another copy from the local Technical Dept. or download it directly from the company's website.

All local regulations, including those referring to national and European standards, must be observed when installing the appliance.

In Italy, for the installation of systems with a biomass below 35KW, refer to the Ministerial Decree 37/08 and the qualified installation technician with the suitable requirements must issue a certificate of compliance for the system installed. (By system we intend Stove+Flue+Air inlet).

## REVISIONS TO THE PUBLICATION

The content of this manual is strictly technical and the property of MCZ Group Spa.





No part of this manual may be translated into other languages, adapted and/or reproduced, even in part, in other mechanical and/or electronic form or media, for photocopies, recordings or other, without the prior written authorisation of MCZ Group Spa.

The company reserves the right to make changes to the product at any time without prior notice. The owner company reserves its rights according to law.

## CARE OF THE MANUAL AND HOW TO CONSULT IT

- Take care of this manual and store it in an easily and quickly accessible place.
- Should this manual be lost or destroyed, request a copy from your retailer or directly from the authorised Technical assistance department. It can also be downloaded from the company's website.
- "**Bold text**" requires special attention.
- "*Text in italics*" is used to draw attention to other paragraphs in the manual or for any additional clarifications.
- "Note" provides the reader with additional information.

## SYMBOLS USED IN THE MANUAL

	<b>ATTENTION:</b> carefully read the relative message as <b>failure to comply with the information provided may result in serious damage to the product and danger to the persons who use it.</b>
	<b>INFORMATION:</b> failure to comply with these provisions will compromise use of the product.
	<b>OPERATING SEQUENCES:</b> sequence of buttons to be pressed to access the menus or perform adjustments.
	<b>MANUAL</b> carefully read this manual or the relative instructions.

### SAFETY WARNINGS

- **Installation, electrical connection, function test and maintenance must only be carried out by authorised and qualified personnel.**
- **Install the product in accordance with all local and national legislation and regulations in force in the region or country.**
- **Bad use or improper maintenance of the product can bring to a serious risk of explosion in the combustion chamber.**
- Only use the fuel recommended by the manufacturer. The product must not be used as an incinerator. It is strictly forbidden to use liquid fuel.
- Do not put any fuel other than wood pellets in the hopper.
- The instructions provided in this manual must always be complied with to ensure the product and any electronic appliances connected to it are used correctly and accidents are prevented.
- **This appliance can be used by children aged 8 years and above and persons with reduced physical, sensory or mental capabilities or lack of experience and knowledge if they have been given supervision or instruction concerning use of the appliance in a safe way and understand the hazards involved. Children must not play with the appliance. Cleaning and user maintenance shall not be carried out by children without supervision.**
- The user, or whoever is operating the product, must read and fully understand the content of this installation guide before performing any operation. Errors or incorrect settings can cause hazardous conditions and/or poor operation.
- Do not climb on or lean on the product.
- Do not dry laundry on the product. Any drying racks or the like must be kept at a safe distance from the product. **Fire hazard.**
- *All liability for improper use of the product is entirely borne by the user and relieves the manufacturer of any civil and criminal liability.*
- Any type of tampering or unauthorised replacement with non-original spare parts may be hazardous for the operator's safety and relieves the company of any civil and criminal liability.
- Many surfaces of the product get very hot (door, handle, glass, smoke outlet

## 1-WARNINGS AND WARRANTY CONDITIONS

pipes, etc.). **Avoid coming into contact with these parts without adequate protective clothing or suitable equipment, such as gloves with thermal protection** or “cold handle” operating systems.

- **It is forbidden to operate the product with the door open or the glass broken.**
- The product must be powered by an electrical system that is equipped with an effective earthing device.
- Switch the product off in the event of a fault or malfunction.
- Accumulated unburnt pellets in the burner after each “failed ignition” must be removed before lighting again. Check that the burner is clean and positioned properly before lighting again.
- **Shut the stove down in the event of a breakdown or bad running and contact the specialised technician immediately.**
- **Pellets must not be fed manually into the burner – this wrong behaviour can generate an abnormal amount of unburnt gas, with a risk of explosion in the chamber.**
- **Accumulated unburnt pellets in the burner after a failed ignitions must be removed before lighting.**
- Failure to clean and maintain the brazier can result in improper running and explosions within the stove. Make sure you remove and clear the holes in the brazier and any loose encrustations every time you empty the ash from the stove or every time you have a failed ignition. Make sure that the holes in the brazier are never reduced in size as this will affect the safe performance of the stove if not maintained.
- Do not wash the product with water. Water could get inside the unit and damage the electrical insulation and cause electric shocks.
- If there is a fire in the flue, extinguish the stove, disconnect it from the power supply and never open the door. Then contact the competent authorities.
- Do not light the stove with flammable materials if the ignition system breaks down.
- Do not stand for a long time in front of the product in operation. Do not overheat the room you are in and where the product is installed. This may harm one’s

## 1-WARNINGS AND WARRANTY CONDITIONS

physical conditions and cause health problems.

- Install the product in rooms that do not pose a fire hazard and are equipped with power and air supplies and smoke outlets.
- In the event of fire in the chimney, turn off the device, disconnect it from the mains and do not open the door whatsoever. Then contact the competent authorities.
- The product and the cladding must be stored in a dry place and must not be exposed to weathering.
- It is recommended not to remove the feet that support the product in order to ensure adequate insulation, especially if the flooring is made of flammable materials.
- In the event of a malfunction of the ignition system, do not force it on by using flammable materials.
- Special maintenance must only be performed by authorised and qualified personnel.
- Assess the static conditions of the surface on which the weight of the product will rest and provide suitable insulation if it is made of flammable material (e.g. wood, fitted carpet or plastic).
- Live electrical parts: only power the product once it has been fully assembled.
- Disconnect the product from the 230V power supply before performing any maintenance operations.
- **IF ANY SMOKE LEAKAGE IS SEEN WITHIN THE ROOM OR THE APPLIANCE SUFFERS FROM AN EXPLOSIVE IGNITION PLEASE TURN OFF THE APPLIANCE, VENTILATE THE ROOM AND CONTACT THE INSTALLER/SERVICE TECHNICIAN IMMEDIATELY.**

# 1-WARNINGS AND WARRANTY CONDITIONS

## INFORMATION

- If there are any issues, contact the retailer or a qualified technician authorised by MCZ. In the event of a repair, request the use of original spare parts.
- Only use types of fuel recommended by MCZ (for Italy, pellets with a 6 mm diameter and pellets with a 6-8 mm diameter for other European countries), which must only be loaded with an automatic feed system.
- Periodically check and clean the smoke outlet duct (connection to the flue).
- Accumulated unburnt pellets in the burner after a series of failed ignitions must be removed before lighting it again.
- The pellet stove is not a cooking appliance.
- Always keep the cover of the fuel tank closed.
- Keep this instruction manual, which will be an integral part of the stove for the whole of its service life. If the product is sold or transferred to another user, ensure the manual is also handed over.
- If lost, contact MCZ or the authorised dealer to request a copy.

## INTENDED USE

The product only works with wood pellets and must be installed indoors.

## PRODUCT PERFORMANCE CHECKS.

All our products undergo ITT TESTS carried out by a notified laboratory (system 3) and in accordance with (EU) Regulation number 305/2011 “Construction products”, according to standard EN 14785:2006 (pellets) and “Machinery Directive” EN 303-5 (boilers).

In the case of tests for any market surveillance or inspections by third parties, please consider the following warnings:

- to reach the declared performance levels, the product must perform an operating cycle of at least 15/20 hours beforehand
- use the average draught of the combustion smoke specified in the “product technical specifications” table
- the type of pellets used must comply with current EN ISO 17225-2 regulations
- the amount of fuel may vary according to the length and calorific value of the fuel. This may require some adjustments to stay in line with the hourly consumption specified in the “product technical specifications” table. A1 pellets ensure an overall calorific value within tight margins compared to the test pellets used. However, size considerably affects performance, therefore on average it must not be less than 24 mm long and with a 6mm diameter
- in the case of a wood-burning product, check the correct residual moisture content of the fuel, which must not be less than 12% or more than 20%. As the moisture increases, different combustion air settings are required. The settings are to be carried out via the combustion air register, thereby modifying the mixture between primary and secondary air
- it is required to check the operation of devices that can affect performance (for example air fans or electrical safety devices) in case of damage due to handling.
- maximum performance can be achieved at the maximum flame and ventilation power.
- strictly comply with the withdrawal points required by regulations both in terms of emissions and temperature.

# 1-WARNINGS AND WARRANTY CONDITIONS

## WARRANTY CONDITIONS

The firm covers the product, **with the exception of the parts prone to normal wear** that are listed below, for a period of **2 (two) years** from the date of purchase as proved by:

- a document to serve as proof of purchase (invoice and/or receipt) that shows the name of the vendor and the date on which the purchase was made;
- forwarding of the completed warranty certificate within 8 days of purchase.

Furthermore, in order for the warranty to be valid, the device must be installed and calibrated by qualified personnel, and where necessary, the user must be issued with a declaration of conformity and correct product operation.

We recommend performing a functional test of the product before completion with the relative finishes, if applicable (claddings, painting of walls, etc.).

Installations that do not meet the current standards, improper use and lack of maintenance as required by the manufacturer, void the product warranty.

The warranty is valid on the condition that the instructions and warnings contained in the user and maintenance manual are observed, and therefore the product is used correctly.

Replacement of the entire system or repair of one of its components does not extend the warranty period, and the original expiry date remains unchanged.

The warranty covers the replacement or free repair **of parts recognised as being faulty at source due to manufacturing defects**. In the event of a fault, to benefit from the warranty, the customer must keep the warranty certificate and provide it along with the document given at the time of purchase to the Technical Service Centre.

## EXCLUSIONS

The warranty does not cover malfunctions and/or damage to the appliance that arise due to the following causes:

- Damage caused during transport and/or handling
- all parts that develop faults due to negligence or improper use, incorrect maintenance, installation that does not comply with the manufacturer's instructions (always refer to the installation guide provided with the appliance)
- incorrect sizing with regard to the use or faults in the installation or failure to implement the necessary measures to ensure proper execution
- improper overheating of the equipment, i.e. the use of fuels not conforming to the types and quantities indicated in the provided instructions
- further damage caused by incorrect user operations in an attempt to fix the initial fault
- worsening of the damage caused by the user continuing to operate the appliance even after the fault has been detected
- in the presence of a boiler, any corrosion, deposits or breakage caused by water flow, condensation, hardness or acidity of the water, improperly performed descaling treatments, water outage, mud or limescale deposits
- inefficiency of chimneys, flues or parts of the system affecting the appliance
- damage caused by tampering with the appliance, atmospheric agents, natural disasters, vandalism, electrical discharges, fires, faults in the electric and/or hydraulic system.
- Failure to have yearly stove maintenance performed by an authorised technician or qualified personnel shall render the warranty void.

The following are also excluded from this warranty:

- parts subject to normal wear such as gaskets, glass, cladding and cast iron grilles, painted, chrome-plated or gilded parts, handles and electric cables, bulbs, indicator lights, knobs, all parts which can be removed from the firebox.
- Variations in colour of the painted or ceramic/serpentine parts and crazed ceramics as they are natural characteristics of the material and product use.
- masonry work
- system parts (if included) not supplied by the manufacturer



## 1-WARNINGS AND WARRANTY CONDITIONS

Any technical operations on the product to remove the aforementioned defects and consequent damage must be agreed upon with the Technical Service Centre, who reserves the right to accept the relative job or not. However, said operations shall not be carried out under warranty but as technical support to be granted as part of any potentially and specifically agreed conditions and in accordance with the fees in force for the work to be carried out.

The user will also be charged for any costs incurred to remedy the incorrect technical operations, tampering or damage to the appliance, not attributable to original faults.

Without prejudice to the legal or regulatory limits, the warranty does not cover the containment of atmospheric and acoustic pollution.

***The company declines all liability for any damage which may be caused, directly or indirectly, to persons, animals or objects as a consequence of non compliance with any provision specified in the manual, especially warnings regarding installation, use and maintenance of the appliance.***

### SPARE PARTS

In the event of a malfunction, consult the retailer who shall forward the call to the Technical Assistance Department.

Only use original spare parts. The retailer or service centre can provide all necessary information regarding spare parts.

We do not recommend waiting for the parts to get worn out before having them replaced. It is crucial to perform regular maintenance checks.



***The company declines all liability if the product and any other accessory is used improperly or modified without authorisation.***

***All parts must be replaced with original spare parts.***

### WARNINGS FOR CORRECT DISPOSAL OF THE PRODUCT.

The owner is the sole party responsible for demolishing and disposing of the product. This must be performed in compliance with the laws related to safety and environmental protection in force in their country.

At the end of its working life, the product must not be disposed of as urban waste.

It must be taken to a differentiated waste collection centre set up by the local authorities or to a retailer that provides this service.

Separating and recycling prevents potential negative effects on the environment and health (often caused by inappropriately disposing of product parts). It also allows materials to be recovered in order to obtain significant savings of energy and resources.

## 1-WARNINGS AND WARRANTY CONDITIONS

Our solid bio-combustible products, (hereinafter called "Products") are designed and manufactured in compliance with one of the following European standard harmonised to Regulation (UE) no. 305/2011 for construction products:

**EN 14785:** "Residential space heating appliances fired by wood pellets"

**EN 13240:** "Roomheaters fired by solid fuel"

**EN 13229:** "Inset appliances including open fires fired by solid fuels"

**EN 12815:** "Residential cookers fired by solid fuel"

The products also comply with the essential requirements of Directive **2009/125/EC (Eco Design)** and, where applicable, Directives:

**2014/35/EU** (LVD - Low Voltage directive)

**2014/30/EU** (EMC - Electromagnetic Compatibility directive)

**2014/53/EU** (RED – Radio Equipment directive)

**2011/65/EU** (RoHS)

Having specified the above, we highlight and report that:

- **This manual and technical data sheet, also available on our website**, bear all of the specific indications and necessary and essential information to choose the product, to install it correctly and to properly size the smoke expulsion system;
- the Products must be **installed, controlled and serviced** by qualified personnel, according to the instructions in this manual and in compliance with local laws and installation and maintenance standards in force in individual countries, so as to provide an efficient heating system, properly sized according to the needs of the home;
- **if the Products are thermally stressed**, constantly operating for several hours at high power (e.g. 3, 4 hours a day at outputs P4 or P5), we recommend more frequent cleaning and reducing the interval between routine maintenance operations according to the operating condition of the product. We furthermore point out that these operating conditions increase the risk of premature wear of the product, especially those parts exposed to the direct heat of the fire (e.g. combustion chamber), the original condition of which can undergo modifications and deterioration which, among other things, could generate noise during operation of the unit due to mechanical expansion.

The manufacturer will not be held liable if the above information is ignored.

We therefore recommend, in addition to complying with the cleaning, routine and extraordinary maintenance instructions provided, to make meticulous use of the unit using the intended Timer and modulation programs, to correctly manage the internal temperature of the structure.

## 2-INSTALLATION



**The instructions in this chapter refer explicitly to the Italian installation regulation UNI 10683. In any case, always observe the regulations in force in the country of installation.**

### PELLETS

Wood pellets are manufactured by extruding sawdust which is produced during the processing of natural dried wood (without paint). The compactness of the material is guaranteed by the lignin contained in the wood itself and allows the pellets to be produced without glue or binders.

The market offers different types of pellets with characteristics that vary according to the wood mixtures used. The diameter varies between 6 and 8 mm, with a standard length ranging from 3 to 40 mm. A good quality pellet has a density of between 600 and 750 or more kg/cubic metres and a moisture content that accounts for 5 to 8% of its weight.

Pellets have technical advantages besides being an ecological fuel, as the wood residue is used completely, thereby achieving cleaner combustion than that of fossil fuels.

While good-quality wood has a calorific value of 4.4 kW/kg (15% moisture, after about 18 months of seasoning), that of pellets is around 4.9 kW/kg. To ensure good combustion, the pellets must be stored in a dry place and protected from dirt. Pellets are usually supplied in 15 kg bags, therefore, storing them is very convenient.



15 Kg BAG OF PELLETS

Good quality pellets guarantee good combustion, thereby decreasing harmful emissions into the atmosphere.



**The poorer the quality of the fuel, the more often the internal parts of the brazier and combustion chamber need to be cleaned.**

The main quality certifications for pellets currently available on the European market guarantee that the fuel complies with class A1/A2 according to ISO 17225-2 (ex EN 14961). These certifications include, for example, **ENplus**, **DINplus**, **Ö-Norm M7135**, and specifically assure that the following characteristics are complied with:

- calorific value: 4.6 - 5.3 kWh/kg.
- Water content:  $\leq 10\%$  of the weight.
- Percentage of ash: max 1.2% of the weight (A1 less than 0.7%).
- Diameter:  $6 \pm 1/8 \pm 1$  mm.
- Length: 3-40 mm.
- Content: 100% untreated wood without the addition of binding agents (max 5% bark).
- Packaging: in sacks made from ecologically compatible or biologically decomposing material.



**The company strongly recommends using certified fuel for its products (ENplus, DINplus, Ö-Norm M7135). Poor quality pellets or others that do not comply with the characteristics specified previously may compromise the operation of your product and can therefore make the guarantee and product liability invalid.**

## 2-INSTALLATION

### FOREWORD

The installation position must be chosen according to the room, smoke extraction system and flue. Check with local authorities whether there are any restrictive regulations in force regarding the combustion air inlet, the smoke outlet system, the flue or the chimney pot. The manufacturer declines all responsibility in the event of installations that do not comply with the laws in force, incorrect room air exchange, electrical connection non-compliant with the standards and inappropriate use of the appliance. The installation must be carried out by a qualified technician, who must issue a declaration of conformity of the system to the purchaser and shall assume full responsibility for final installation and consequent good operation of the product.

In particular one must ensure that:

- there is a suitable combustion air inlet and smoke outlet in compliance with the type of product installed
- other stoves or devices installed do not cause negative pressure in the room where the product is installed (for sealed appliances only, a maximum of 15 Pa of negative pressure in the room is allowed)
- when the product is switched on there is no reflux of smoke in the room
- smoke extraction takes place in full safety (sizing, smoke seal, distances from flammable materials...).

**We especially recommend checking the data plates of the flue for the safety distances that must be observed in the presence of combustible materials and the type of insulating material to be used. These indications must be followed strictly to prevent serious harm to people and to the integrity of the home.** Installation of the appliance must ensure easy access to clean the appliance itself, the smoke outlet pipes and the flue. **It is forbidden to install the stove in rooms with a fire hazard. Installation in studio flats, bedrooms and bathrooms is only permitted with sealed or closed appliances equipped with suitable combustion air ducting directly outside. Always maintain adequate distance and protection in order to prevent the product from coming into contact with water.**

If there are several appliances installed, the external air inlet must be sized accordingly.

### MINIMUM DISTANCES

It is recommended to install the stove detached from any walls and/or furniture, with a minimum clearance to allow effective aeration of the appliance and a good distribution of heat in the room. Comply with the distances from flammable or heat-sensitive objects (sofas, furniture, wood panelling, etc.) as specified below. The frontal distance from flammable materials must be at least as specified in the product's technical data table.

If there are particularly delicate objects such as furniture, curtains or sofas, increase the stove distance accordingly.



***If the floor is made of wood, it is recommended to fit a floor protection sheet in compliance with the standards in force in the country of installation.***

THEA HYDRO 16 S1 THEA HYDRO 23 S1	Non-flammable walls	Flammable walls
	A = 2 cm B = 5 cm	A = 2 cm B = 20 cm

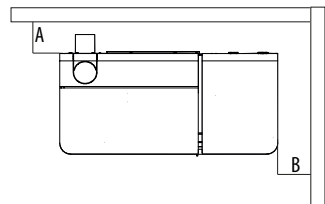

If the floor is made of combustible material, it is recommended to use a protection made of non-combustible material (steel, glass...) that also protects the front from any falling combusted material during cleaning operations.

The appliance must be installed on a floor with adequate load capacity.

If the existing construction does not meet this requirement, appropriate measures must be taken (for example a load distribution plate).

## 2-INSTALLATION

### FOREWORD

This Flue chapter has been drawn up with reference to the provisions of European Standards (EN13384 - EN1443 - EN1856 - EN1457). The chapter provides indications for installing an efficient and correct flue but is under no circumstances to substitute the regulations in force, which the qualified manufacturer must be in possession of. Check with local authorities whether there are any restrictive regulations in force regarding the combustion air inlet, the smoke outlet system, the flue or the chimneypot. The Company declines all liability relating to the poor functioning of the stove if this is due to the use of an insufficiently sized flue in violation of the standards in force.

### FLUE

The flue or chimney is of great importance for the proper operation of a solid fuel-burning heating appliance with forced draught. As modern heating appliances have high efficiency with cooler flue gases and consequently less draught, it is therefore crucial for the flue to be built to professional standard and always kept in perfect working order. A flue for a pellet/wood fired appliance must be at least category T400 (or greater if the appliance requires so) and resistant to soot fires. Smoke must be extracted through a single flue made of insulated steel (A) or an existing flue that complies with the intended use (B).

A simple air shaft made of cement must be suitably piped. In both solutions there must be an inspection cap (AT) and/or inspection access panel (AP) - FIG.1.

It is prohibited to connect more than one wood/pellet appliance (\*) or any other type of appliance (cowl vents ...) to the same flue.

(\*) unless there are national derogations (for instance in Germany), which under suitable conditions allow for the installation of several appliances in the same fireplace. In any case, strictly follow the product/installation requirements of the relative regulations/legislation in force in that country

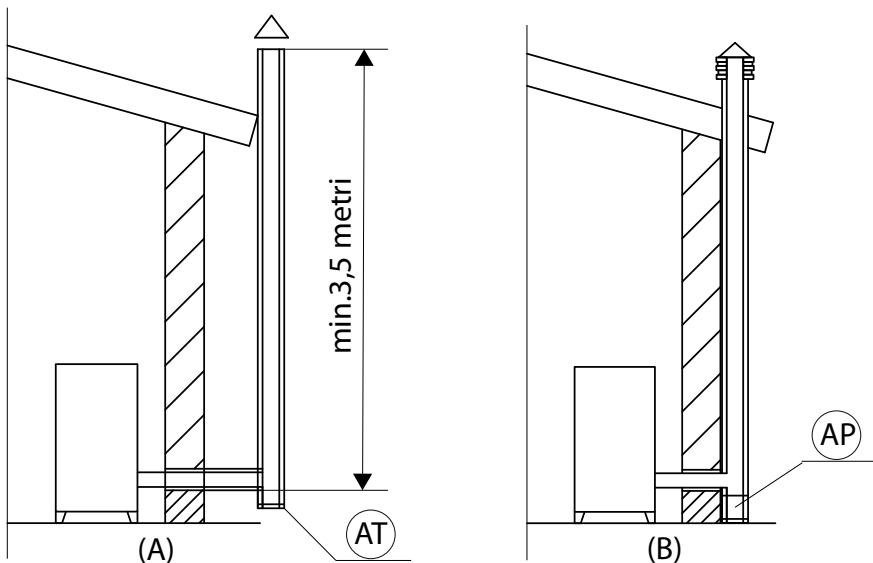

FIGURE 1 - FLUE

## 2-INSTALLATION

### TECHNICAL SPECIFICATIONS

Have the efficiency of the flue checked by an authorised technician.

The flue must be sealed against flue gases, in a vertical direction without narrowing, be made with materials impermeable to smoke, condensation, thermally insulated and suitable to resist normal mechanical stress over time (we recommend fireplaces made of A/316 or refractory material with insulated round section double chamber). It must be suitably insulated externally to avoid condensation and reduce the smoke cooling effect. It must be separated from combustible or easily flammable materials via an air gap or insulating materials: check the distance specified by the chimney manufacturer according to EN1443. The chimney opening must be in the same room as the appliance, or at most in the adjoining room, and have a soot and condensation collection chamber beneath the opening, and be accessible via a sealed metal door.

#### FLAT ROOF

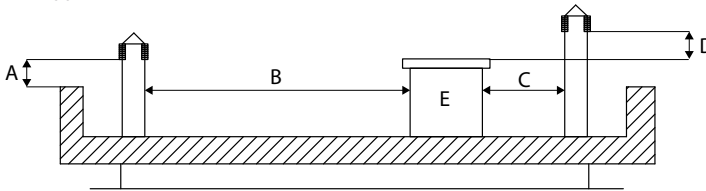

A = 0.50 metres  
B = DISTANCE > 2 metres  
C = DISTANCE < 2 metres  
D = 0.50 metres  
E = TECHNICAL VOLUME

FIGURE 2

#### ROOF AT 15°

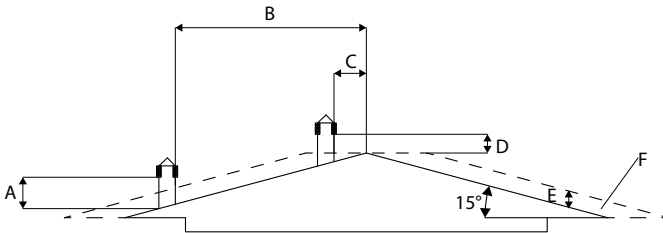

A = MIN. 1.00 metre  
B = DISTANCE > 1.85 metres  
C = DISTANCE < 1.85 metres  
D = 0.50 metres ABOVE HIGHEST POINT  
E = 0.50 metres  
F = REFLUX AREA

FIGURE 3

#### ROOF AT 30°

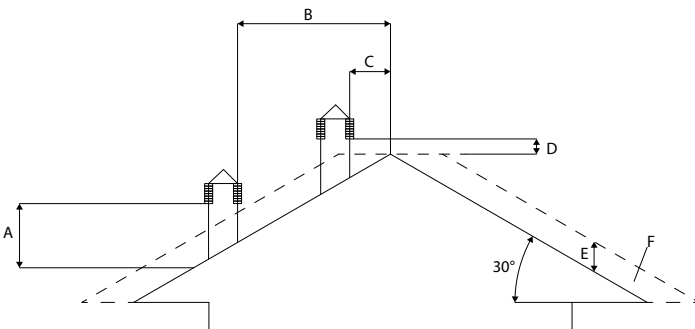

A = MIN. 1.30 metres  
B = DISTANCE > 1.50 metres  
C = DISTANCE < 1.50 metres  
D = 0.50 metres ABOVE HIGHEST POINT  
E = 0.80 metres  
F = REFLUX AREA

FIGURE 4

## 2-INSTALLATION

### ROOF AT 60°

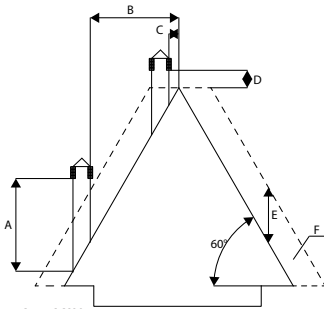

FIGURE 5

- A = MIN. 2.60 metres
- B = DISTANCE > 1.20 metres
- C = DISTANCE < 1.20 metres
- D = 0.50 metres ABOVE HIGHEST POINT
- E = 2.10 metres
- F = REFLUX AREA

### ROOF AT 45°

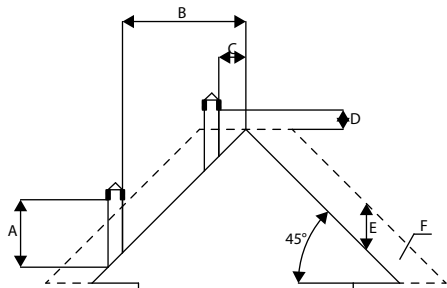

FIGURE 6

- A = MIN. 2.00 metres
- B = DISTANCE > 1.30 metres
- C = DISTANCE < 1.30 metres
- D = 0.50 metres ABOVE HIGHEST POINT
- E = 1.50 metres
- F = REFLUX AREA

### SIZING

The negative pressure (draught) of a flue also depends on its height. Check the negative pressure with the values indicated in the technical specifications. The minimum height of the chimney is 3.5 metres.

The interior cross-section of the flue can be round (best solution), square or rectangular (the ratio between the internal sides must be  $\leq 1.5$ ) with the sides joined with a minimum radius of 20 mm. The dimension of the cross-section must be **minimum  $\varnothing 100\text{mm}$** .

The cross sections/lengths of chimneys must be correctly sized in accordance with the general method of calculation of UNI EN13384-1 or other proven efficiency methods.

Some examples of flues available on the market are provided below:

AISI 316 steel chimney with double chamber insulated with ceramic fibre or equivalent resistant up to 400°C.

Refractory chimney with double insulated chamber and external lightweight concrete cladding with cellular material such as clay.

Traditional square-section clay chimney with insulating empty inserts.

Avoid products with an internal rectangular section where the larger side is 1.5 times the smaller side (e.g. 20x40 or 15x30).

#### EXCELLENT

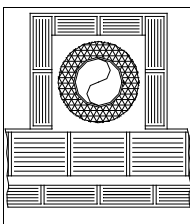

#### GOOD

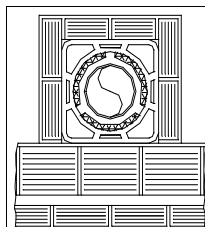

#### POOR

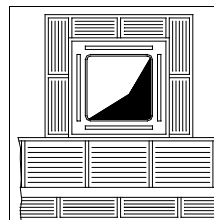

#### VERY POOR

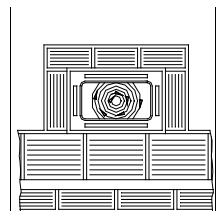

## 2-INSTALLATION

### MAINTENANCE

The flue must be kept clean, since the deposit of soot or unburnt oils reduces the cross-section, blocking the draught and thus compromising the efficient operation of the stove and, if large build-ups accumulate, can catch fire. The flue and chimneypot must be cleaned and checked by a qualified chimney sweep at least once a year. Once the inspection/maintenance has been performed, request a written report that the system is safe. Failure to perform cleaning jeopardises the system's safety.

### CHIMNEYPOT

The chimneypot is a crucial element for correct operation of the heating appliance: we recommend a windproof chimneypot (A), see Figure 7.

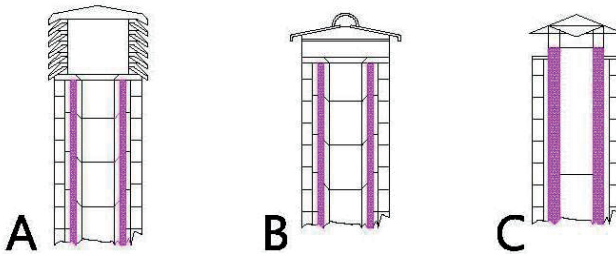

The area of the opening for smoke extraction must be at least double the cross-section of the flue/piped system, and arranged so that the smoke outlet is ensured even in the presence of strong wind. The chimneypot must prevent rain, snow or animals from entering the chimney. The height of outflow into the atmosphere must be beyond the reflux area caused by the shape of the roof or any nearby obstacles (see Figures 2-3-4-5-6).

FIGURE 7

### CHIMNEY COMPONENTS

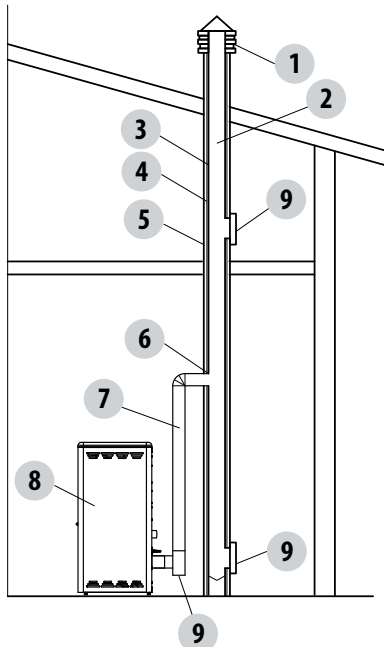

KEY:

- (1) CHIMNEYPOT
- (2) REFLUX CHANNEL
- (3) SMOKE DUCT
- (4) THERMAL INSULATION
- (5) OUTSIDE WALL
- (6) CHIMNEY FITTING
- (7) SMOKE DUCT
- (8) HEAT GENERATOR
- (9) INSPECTION ACCESS PANEL

FIGURE 8



## 2-INSTALLATION

### EXTERNAL AIR INLET

It is mandatory to provide an adequate external air inlet that supplies the combustion air required for the product to work properly. The flow of air between the outside and the installation room may be direct, through an inlet in an external wall of the room (preferable solution see Figure 9 a), or indirect, via air intake from adjoining rooms and connecting permanently with the installation room (see Figure 9 b). Adjoining areas may not include sleeping areas, bathrooms, garages or in general areas with a fire hazard. During installation it is required to check the minimum clearances required to draw air from outside. Take into account the presence of doors and windows that could interfere with the proper flow of air to the stove (see diagram below).

The air inlet must have a minimum net total area of 80 cm<sup>2</sup>: the surface must be increased accordingly if there are other active generators (for example: electric fan for stale air extraction, range cooker hood, other stoves, etc.), which could cause a depression in the room. Make sure that, with all appliances on, the pressure drop between the room and the outside does not exceed the value of 4 Pa (also for Oyster appliances if the combustion air has not been suitably ducted outside). If required, increase the intake section of the air inlet, which must be made at floor level and always protected with a bird-proof outer protection grid and in such a way that it cannot be obstructed by any object.

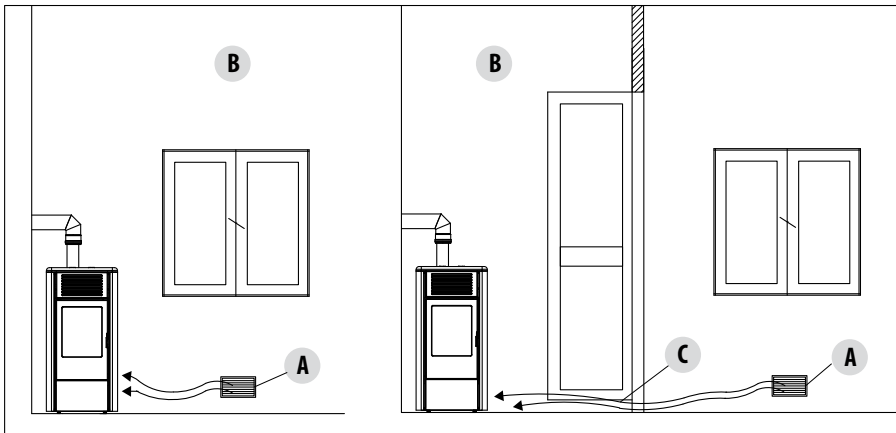
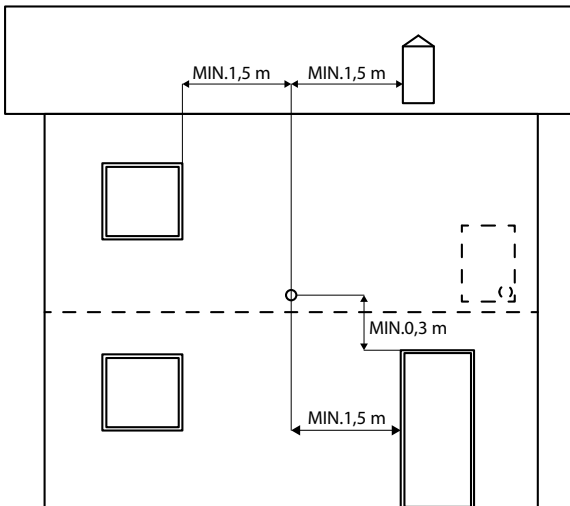

FIGURE 9 A - DIRECTLY FROM OUTSIDE

FIGURE 9 B - INDIRECTLY FROM THE ADJACENT ROOM



A=AIR INLET  
B=ROOM TO BE VENTILATED  
C=INCREASE OF THE GAP UNDER THE DOOR

It is possible to connect the air required for combustion directly to the outside air inlet, by using a pipe of at least Ø50mm, with maximum length of 3 linear metres. Each pipe bend must be considered equivalent to a linear metre. To attach the pipe see the rear of the stove.

For stoves installed in studio flats, bedrooms and bathrooms (where allowed), it is mandatory to connect the combustion air outside. Specifically for sealed stoves the connection must be sealed in order not to compromise the overall sealing of the system.

FIGURE 10

## 2-INSTALLATION

<b>DISTANCE (metres)</b>	<b>The air inlet must be at a distance of:</b>	
1.5 m	BELOW	Doors, windows, smoke outlets, gaps, ....
1.5 m	HORIZONTALLY	Doors, windows, smoke outlets, gaps, ....
0.3 m	ABOVE	Doors, windows, smoke outlets, gaps, ....
1.5 m	AT A DISTANCE	from smoke outlet

### CONNECTION TO THE FLUE

The connection between the flue and the appliance must be via a smoke duct compliant to EN 1856-2. The connecting section must extend no more than 4 m horizontally, with a minimum slope of 3% and with a maximum of 3 x 90° bends (accessible for inspection - do not count the Tee fitting at the appliance outlet).

The diameter of the smoke duct must be equal to or greater than that of the outlet of the appliance ( $\varnothing$  80 mm).

<b>TYPE OF SYSTEM</b>	<b>SMOKE DUCT</b>
Maximum length (with 1 accessible 90° bend)	6.5 metres
Maximum length (with 3 accessible 90° bends)	4.5 metres
Maximum number of accessible 90° bends	3
Horizontal sections (minimum slope 3%)	4 metres

Use a smoke duct according to the regulations in force in the country of installation and verify that it is compatible with the product and installation characteristics. The temperature class of the smoke duct must exceed operating temperatures of the appliance.

It is prohibited to connect more than one appliance to the same smoke duct, or the discharge from hoods above it. It is forbidden to extract the combustion products directly through the wall, whether towards indoor spaces or outdoors.

Should there be flammable or heat-sensitive structures, the smoke duct must respect the safety distances specified in the data plate.

## 2-INSTALLATION

### EXAMPLES OF CORRECT INSTALLATION

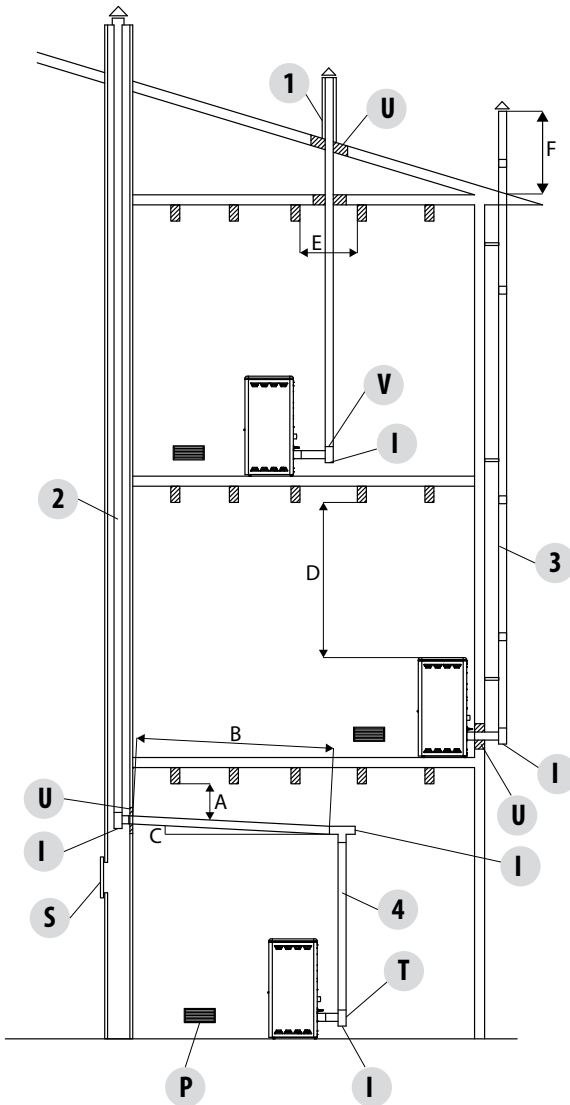

1. Installation of  $\varnothing 120\text{mm}$  flue with hole for the passage of the pipe increased by:  
 minimum 100mm around the pipe if next to non-flammable parts such as cement, brick, etc.; or  
 minimum 300mm around the pipe (or as required by plate data) if next to flammable parts such as wood etc.  
 In both cases, install suitable insulation between the flue and the ceiling.

Always check and comply with the plate data of the flue, specifically the minimum safety distances from combustible materials.

The previous rules also apply for holes made in walls.

2. Old flue, minimum pipe  $\varnothing 100\text{mm}$  with the inclusion of an external access door for chimney cleaning.

3. External flue made of insulated stainless-steel pipes, i.e. with double walls minimum  $\varnothing 100\text{mm}$ : all securely mounted on the wall. With windproof chimneypot. See fig. 7 type A.

4. Ducting system using Tee fittings that allow easy access for cleaning without having to remove the pipes

FIGURE 11

U = INSULATION  
 V = ANY REDUCTION FROM 100 TO 80 MM  
 I = INSPECTION CAP  
 S = INSPECTION ACCESS PANEL  
 P = AIR INLET  
 T = TEE FITTING WITH INSPECTION CAP

A = MINIMUM 40 MM  
 B = MAXIMUM 4 M  
 C = MINIMUM 3°  
 D = MINIMUM 400 MM  
 E = HOLE DIAMETER  
 F = SEE FIG.2-3-4-5-6

### 3-DRAWINGS AND TECHNICAL SPECIFICATIONS

#### DRAWINGS AND CHARACTERISTICS

#### DIMENSIONS OF STUFA THEA HYDRO 16 S1- THEA HYDRO 23 S1

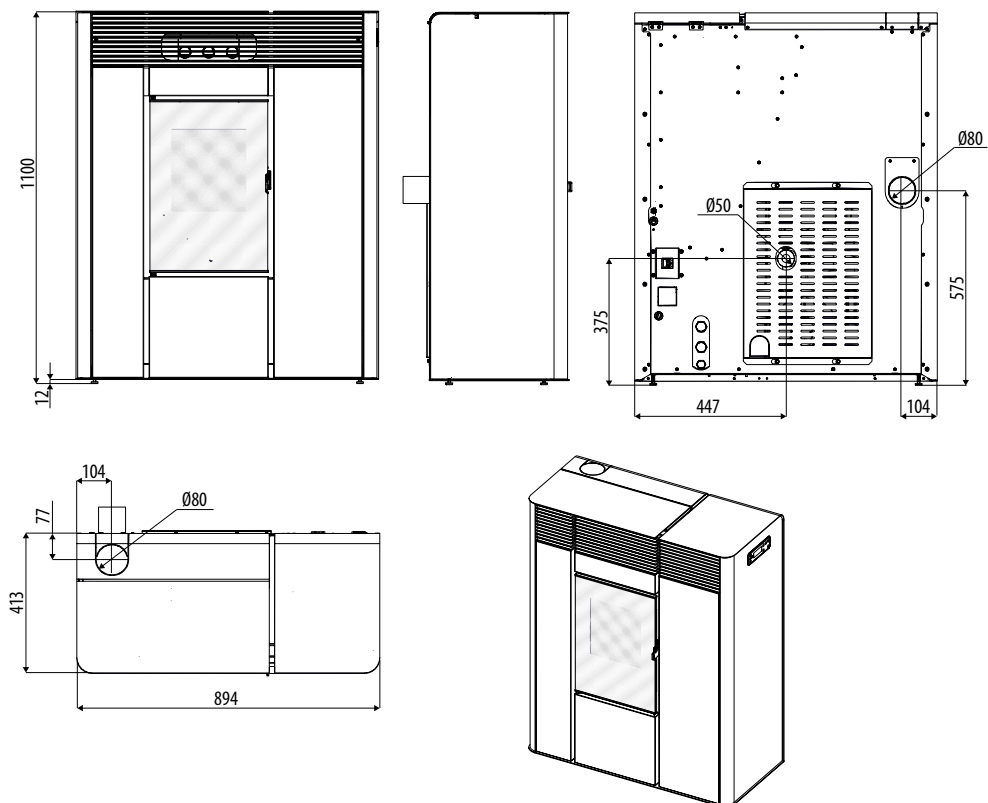

### 3-DRAWINGS AND TECHNICAL SPECIFICATIONS

TECHNICAL SPECIFICATIONS	THEA Hydro 16 S1
Energy Efficiency Class	A++
Nominal output power	16.2 kW (13932 kcal/h)
Nominal power output (H <sub>2</sub> O)	12.9 kW (11094 kcal/h)
Minimum output power	4.7 kW (4042 kcal/h)
Minimum power output (H <sub>2</sub> O)	3.1 kW (2666 kcal/h)
Efficiency at Max	93.3%
Efficiency at Min	96.5%
Temperature of exhaust smoke at Max	118°C <sup>(1)</sup>
Temperature of exhaust smoke at Min	60°C <sup>(1)</sup>
Particulate / OGC / Nox (13%O <sub>2</sub> )	19 mg/Nm <sup>3</sup> - 2 mg/Nm <sup>3</sup> - 109 mg/Nm <sup>3</sup>
CO at 13% O <sub>2</sub> at Min and at Max	0.011 – 0.006%
CO <sub>2</sub> at Min and at Max	7.7% - 11.7%
Smoke mass	10.5 g/sec
Max operating pressure	2,0 bar - 200 kPa
Recommended draught at Max power ***	0.10 mbar - 10 Pa***
Minimum draft allowed at Min power	0.02 mbar - 2 Pa
Hopper capacity	40 litres
Type of pellet fuel	Pellet diameter 6 mm and size 3÷40 mm
Pellet hourly consumption	Min ~ 1.0 kg/h* - Max ~ 3.5 kg/h*
Autonomy	At min ~ 26 h* - At max ~ 8 h*
Heatable volume m <sup>3</sup>	348/40 – 398/35 – 464/30 **
Combustion air inlet	Ø 50 mm
Smoke outlet	Ø 80 mm
Air inlet	80 cm <sup>2</sup>
Rated electrical power (EN 60335-1)	115 W (Max 370 W)
Supply voltage and frequency	230 Volt / 50 Hz
Net weight	185 kg
Weight with packaging	201 kg
Distance from combustible material (back/side/under)	20 / 200 / 0 mm
Distance from combustible material (ceiling/front)	750 / 1000 mm

\* Data that may vary depending on what type of pellets are used

\*\* Volume that can be heated, according to the power requirement per m<sup>3</sup> (respectively 40-35-30 Kcal/h per m<sup>3</sup>)

\*\*\* Value recommended by the manufacturer (non-binding) for optimal product operation

**Tested according to EN 14785 in accordance with European regulation for Construction Products (EU 305/2011)**

**<sup>(1)</sup> To properly size the chimney (in accordance with EN 13884-1), use the smoke temperature exactly detected at the outlet of the appliance, or the above stated temperature increased by 20% (e.g. stated temperature 100°C: product outlet temperature 120°C)**

### 3-DRAWINGS AND TECHNICAL SPECIFICATIONS

TECHNICAL SPECIFICATIONS	THEA Hydro 23 S1
Energy Efficiency Class	A+
Nominal output power	22.8 kW (19608 kcal/h)
Nominal power output (H <sub>2</sub> O)	18.7 kW (16082 kcal/h)
Minimum output power	4.7 kW (4042 kcal/h)
Minimum power output (H <sub>2</sub> O)	3.1 kW (2666 kcal/h)
Efficiency at Max	91.3%
Efficiency at Min	96.5%
Temperature of exhaust smoke at Max	150°C <sup>(1)</sup>
Temperature of exhaust smoke at Min	60°C <sup>(1)</sup>
Particulate / OGC / Nox (13%O <sub>2</sub> )	19 mg/Nm <sup>3</sup> - 3 mg/Nm <sup>3</sup> - 114 mg/Nm <sup>3</sup>
CO at 13% O <sub>2</sub> at Min and at Max	0.011 – 0.014%
CO <sub>2</sub> at Min and at Max	7.7% - 12.5%
Smoke mass	13.9 g/sec
Max operating pressure	2,0 bar - 200 kPa
Recommended draught at Max power ***	0.10 mbar - 10 Pa***
Minimum draft allowed at Min power	0.02 mbar - 2 Pa
Hopper capacity	40 litres
Type of pellet fuel	Pellet diameter 6 mm and size 3 ÷ 40 mm
Pellet hourly consumption	Min ~ 1.0 kg/h* - Max ~ 5.0 kg/h*
Autonomy	At min ~ 26 h* - At max ~ 5 h*
Heatable volume m <sup>3</sup>	490/40 – 560/35 – 654/30 **
Combustion air inlet	Ø 50 mm
Smoke outlet	Ø 80 mm
Air inlet	80 cm <sup>2</sup>
Rated electrical power (EN 60335-1)	115 W (Max 370 W)
Supply voltage and frequency	230 Volt / 50 Hz
Net weight	185 kg
Weight with packaging	201 kg
Distance from combustible material (back/side/under)	20 / 200 / 0 mm
Distance from combustible material (ceiling/front)	750 / 1000 mm

\* Data that may vary depending on what type of pellets are used

\*\* Volume that can be heated, according to the power requirement per m<sup>3</sup> (respectively 40-35-30 Kcal/h per m<sup>3</sup>)

\*\*\* Value recommended by the manufacturer (non-binding) for optimal product operation

**Tested according to EN 14785 in accordance with European regulation for Construction Products (EU 305/2011)**

**<sup>(1)</sup> To properly size the chimney (in accordance with EN 13884-1), use the smoke temperature exactly detected at the outlet of the appliance, or the above stated temperature increased by 20% (e.g. stated temperature 100°C: product outlet temperature 120°C)**

## 4-UNPACKING

### PREPARATION AND UNPACKING

The packaging consists of a recyclable cardboard box in line with RESY standards and a wooden pallet. All packaging materials can be reused for similar use or eventually disposed of as urban solid waste, in compliance with the regulations in force.

After having removed the packaging make sure the product is intact.



Handle the product with suitable means paying attention to the applicable safety regulations in force. Do not turn the packaging over and handle the majolica parts with care.

The stoves are delivered in a single package with steel sides packaged together with the structure and placed at the side. Open the package, remove the cardboard, polystyrene and any straps and position the stove in the preset place making sure that it complies with the requirements.

The stove body or unit must always be kept in a vertical position when handled, and handled using trolleys only. Pay particular attention to the door and its glass, protecting them from mechanical knocks that would compromise their integrity.

If possible, unwrap the stove near the chosen area of installation.

The packaging materials are neither toxic nor harmful.

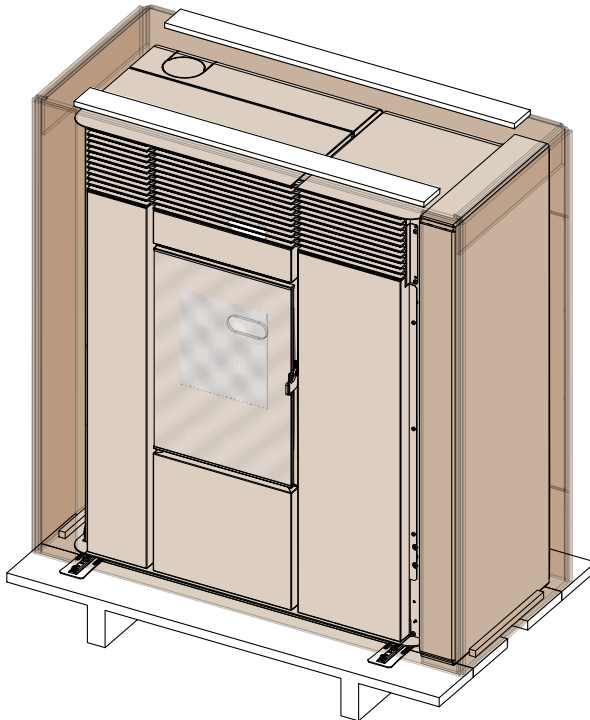

*STOVE PACKAGING WITH METAL CLADDING*

## 4-UNPACKING

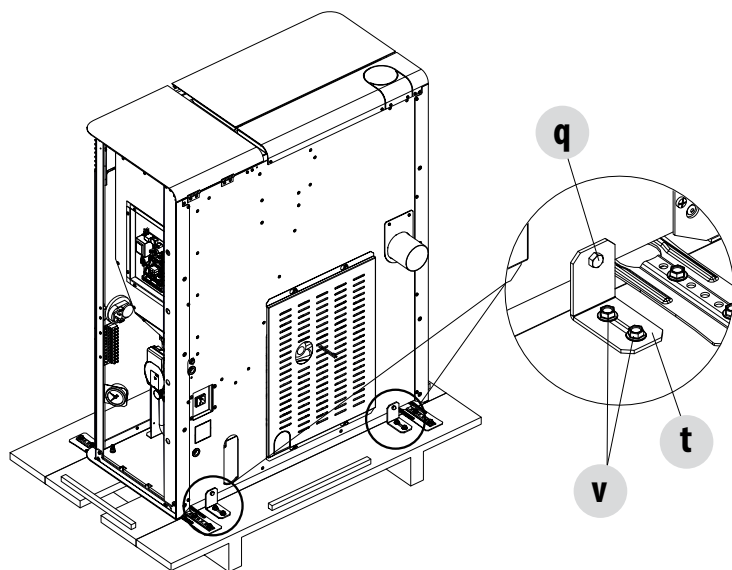

REMOVING THE FASTENING BRACKETS

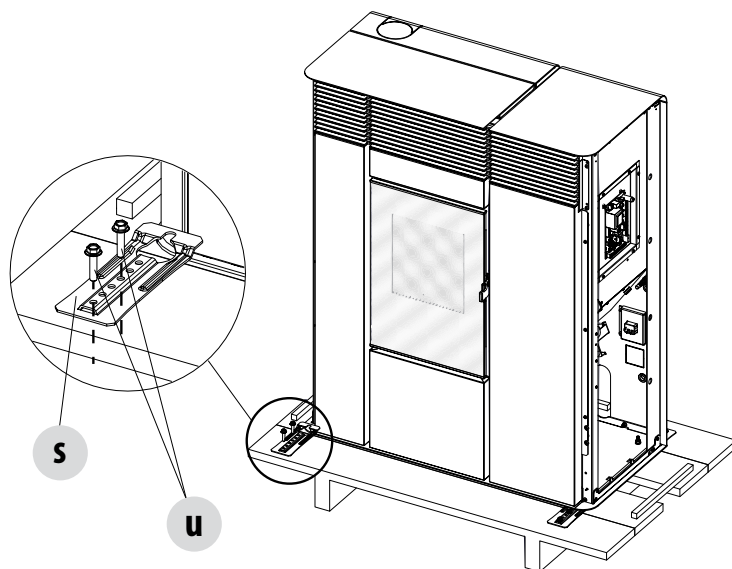

Remove the stoves from the pallet by removing the two screws "u" and the plate "s" from the stove foot. There are four brackets "s".



## 4-UNPACKING

Position the stove and connect it to the flue. Use the 4 adjustable feet (**J**) to get the stove correctly levelled so that the smoke outlet is lined up with the connecting pipe.

If the stove needs to be connected to an outlet pipe which goes through the rear wall (to connect to the flue), take utmost care to make sure that the joint is not forced.



***If the stove smoke outlet is forced or used improperly to lift it or position it, the operation of the stove can be damaged irreparably.***

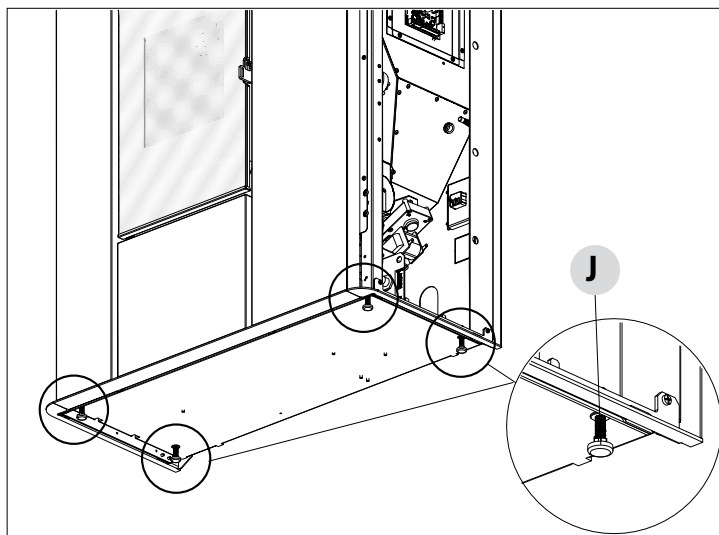

1. TURN THE FEET CLOCKWISE TO LOWER THE STOVE
2. TURN THE FEET ANTICLOCKWISE TO RAISE THE STOVE

## 5 - SMOKE OUTLET CONNECTION

### GENERAL WARNINGS

The stove can have a rear or top smoke outlet. You must purchase the elbow (rear outlet) or the straight pipe (top outlet).

### REAR OUTLET CONNECTION

To install the stove with rear smoke outlet, insert the elbow "T" (not supplied) into the inlet "r" and pass it through the hole "f" on the back of the stove. Make the necessary connections to the flue.

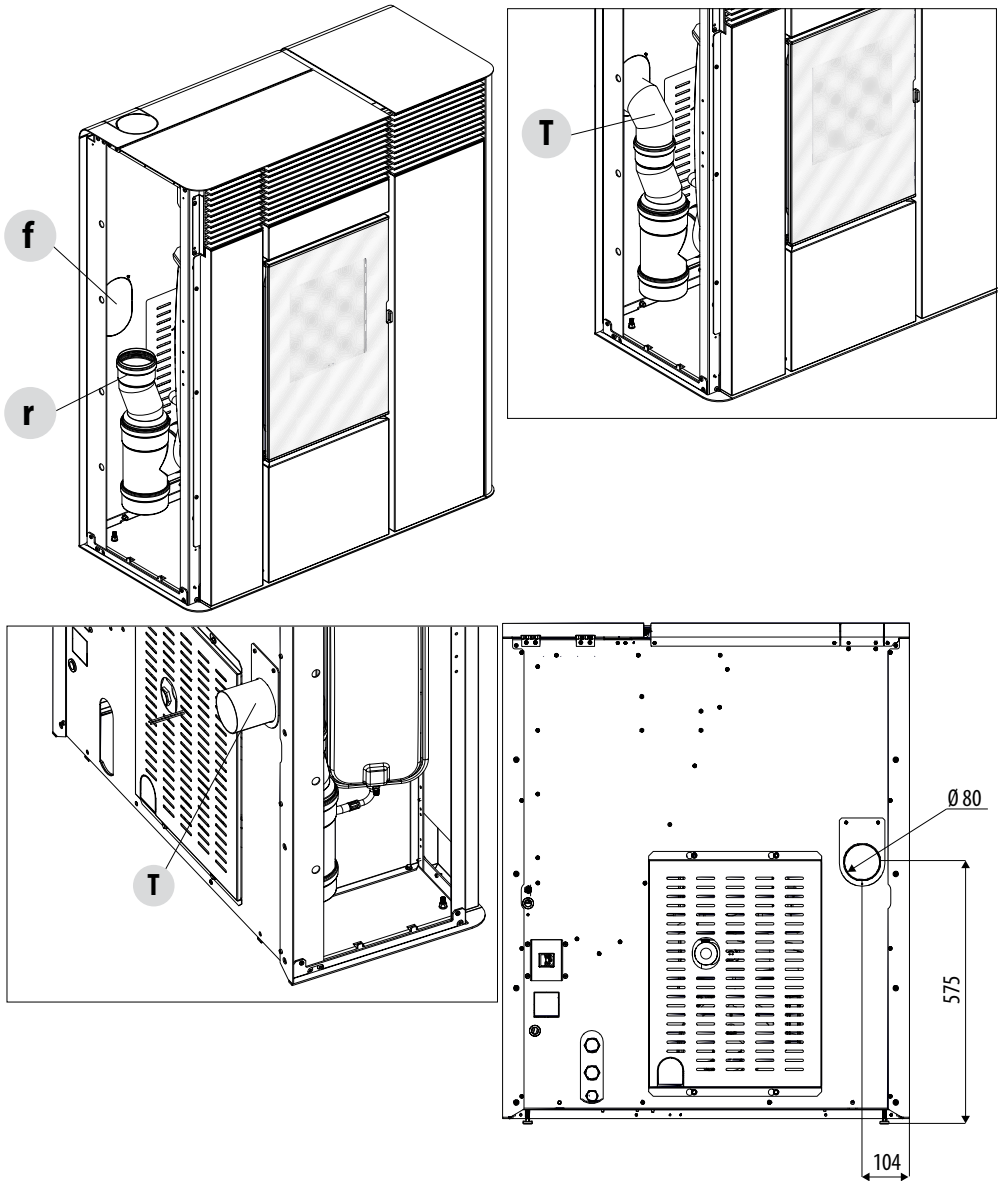

## 5 - SMOKE OUTLET CONNECTION

### TOP OUTLET CONNECTION

To install the stove with top smoke outlet, proceed as follows:

- take out the two screws "x" and remove the piece "S"
- remove the knockout hole in the piece "S" to allow the top smoke outlet

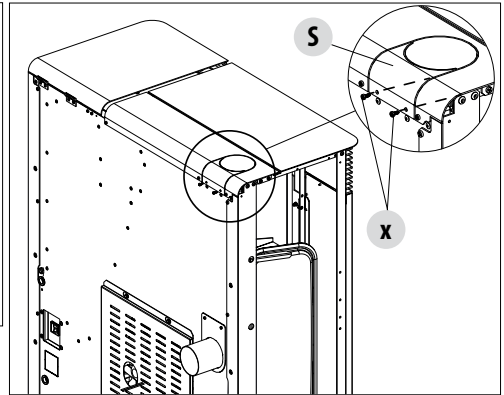
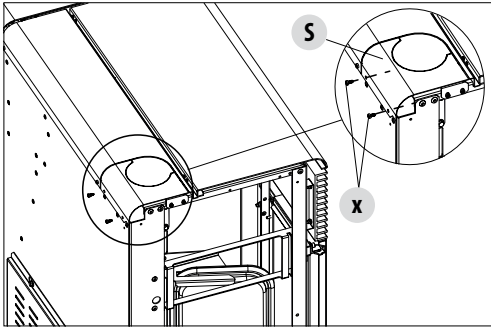

- remove the two screws "y"
- remove the piece "W" (it can be eliminated as it is not needed for the top smoke outlet)
- remove the screw "z" and the hook "S"

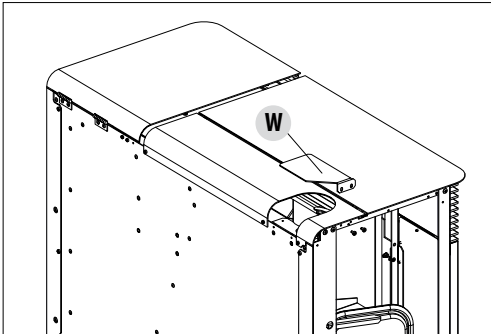
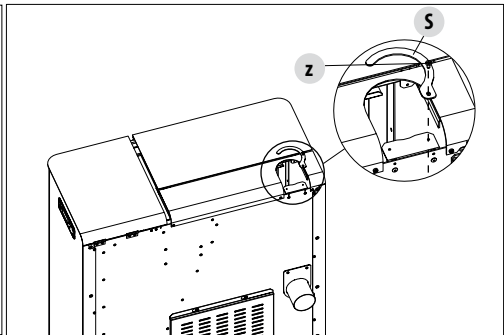
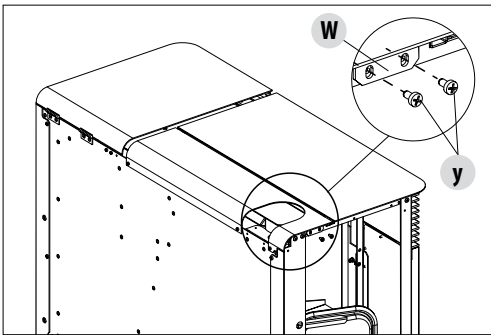

## 5 - SMOKE OUTLET CONNECTION

- insert the linear pipe "T" into the inlet "r" on the stove
- secure the pipe "T" to the stove using the hook "S" and screw "z"

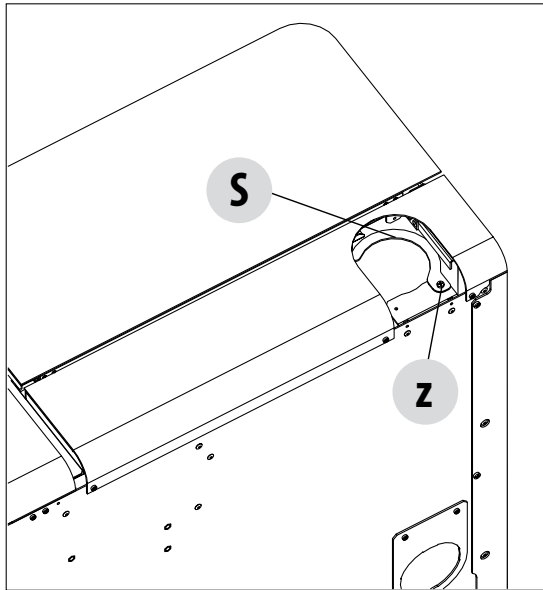
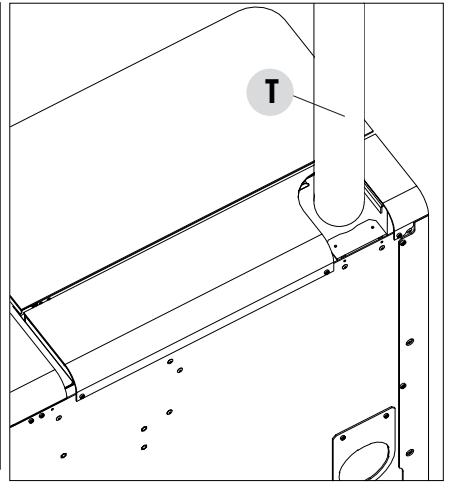
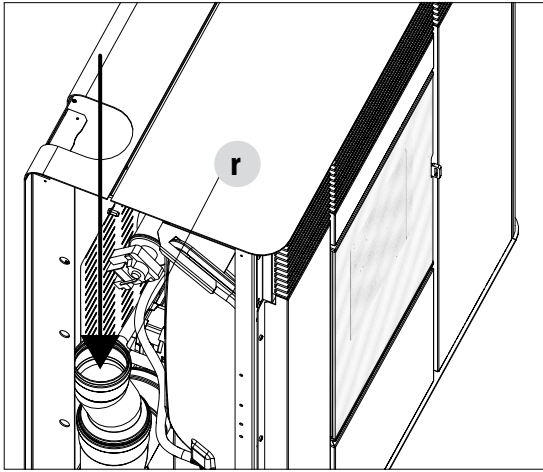

## 6-ASSEMBLING METAL STOVE SIDES



**Live electrical parts: only power the product once it has been fully assembled.**

On delivery, the stove has no metal cladding, as shown in the image below.

Take the box with the metal sides and prepare the material for installation. The metal sides must be fitted according to the instructions on the following pages.

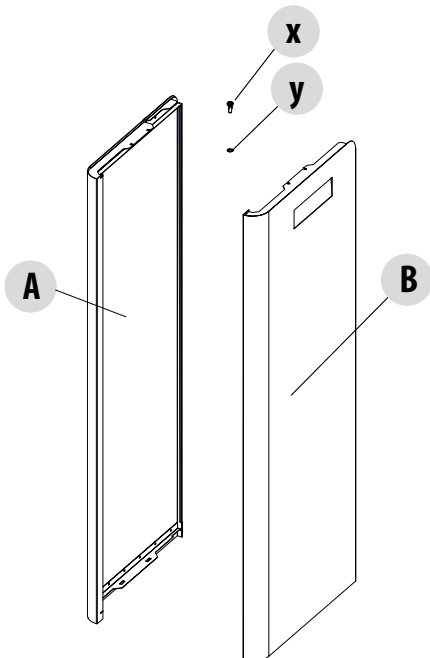
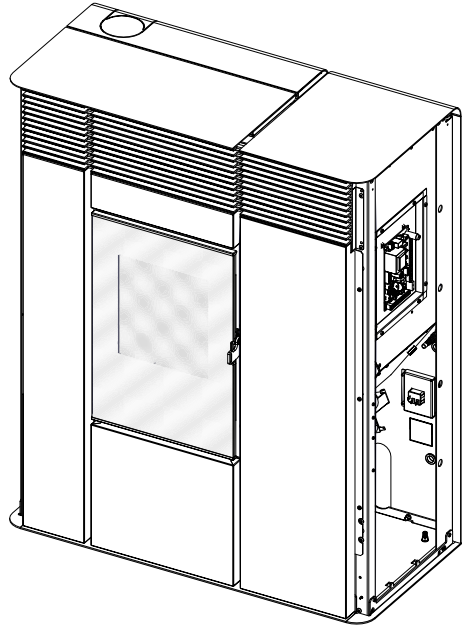

**The claddings are delicate, therefore handle with care.**

### METAL CLADDING

POS.	DESCRIPTION	No.
<b>A</b>	LEFT METAL SIDE	1
<b>B</b>	RIGHT METAL SIDE	1
x	M4X12 SCREW	4
y	M5 NOTCHED WASHER	4

## 6-ASSEMBLING METAL STOVE SIDES

### CONTROL PANEL ASSEMBLY



*The assembly of the aesthetic cladding on the right side also involves assembling the control panel "L".*

- The control panel "L" is pre-assembled by FLAT wiring on the motherboard "T" and temporarily rests on the base of the stove
- detach the flat cable from the control panel "L"

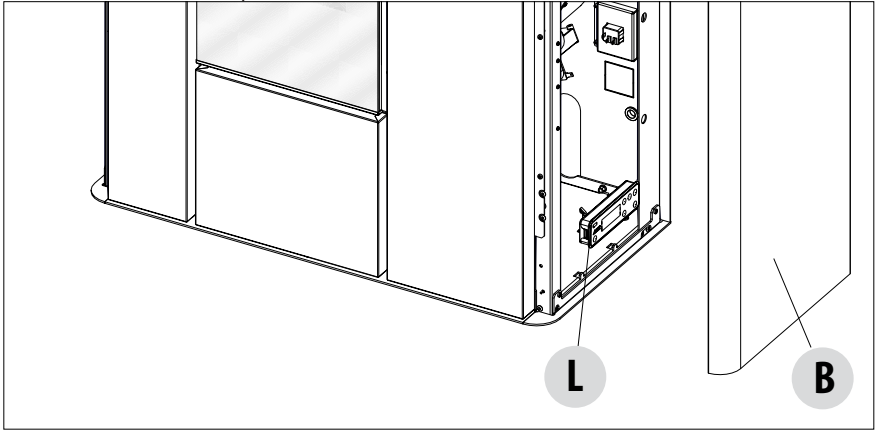

- insert the control panel "L" in the specific hole at the top of the right side.
- reconnect the flat cable to the control panel "L" and install the cladding

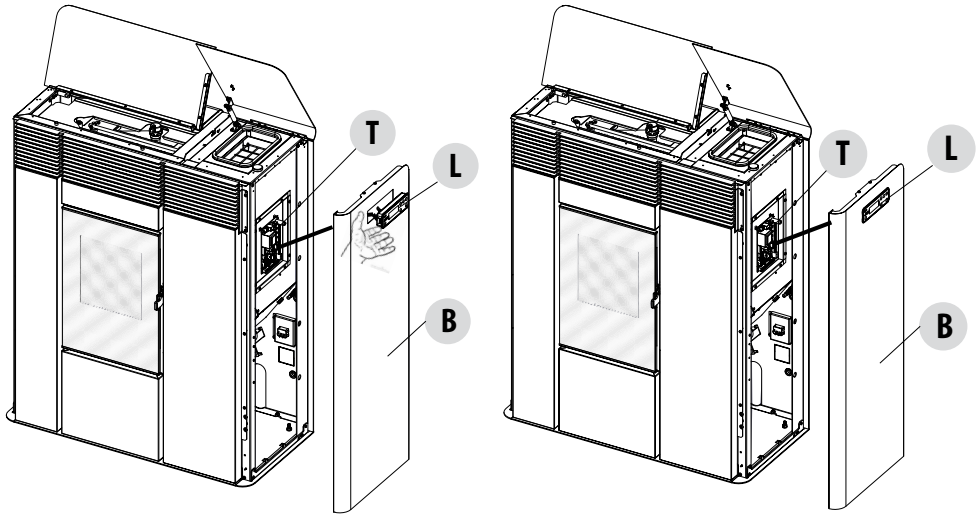

## 6-ASSEMBLING METAL STOVE SIDES

### ASSEMBLY OF SIDE METAL PANEL

You do not need to remove the top to fit the cladding. Simply lift the pellet cover "D" for the right side or the front cover "O" for the left side.

- At the bottom of the stove, insert the holes "s" on the panel "A" into the hooks "v" on the stove

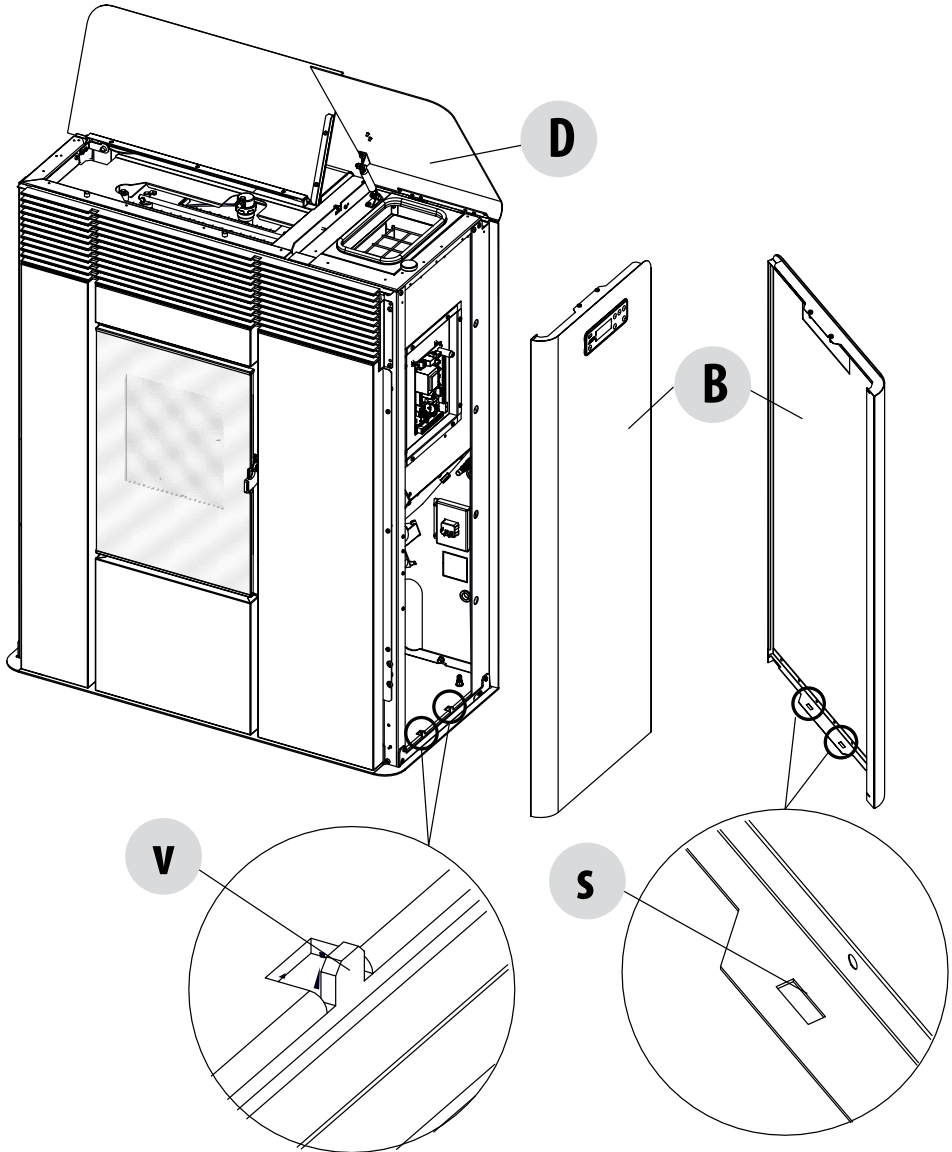

## 6-ASSEMBLING METAL STOVE SIDES

- at the top, secure the panel "A" with the two screws supplied "x"

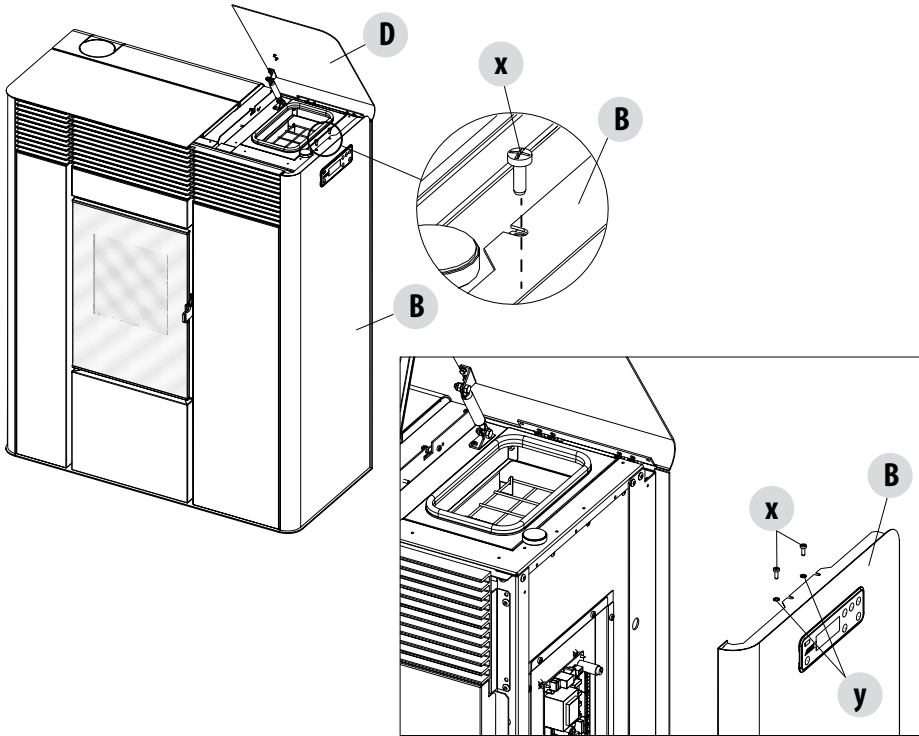

- proceed the same way to fit the left panel "A" lifting the front cover "O"

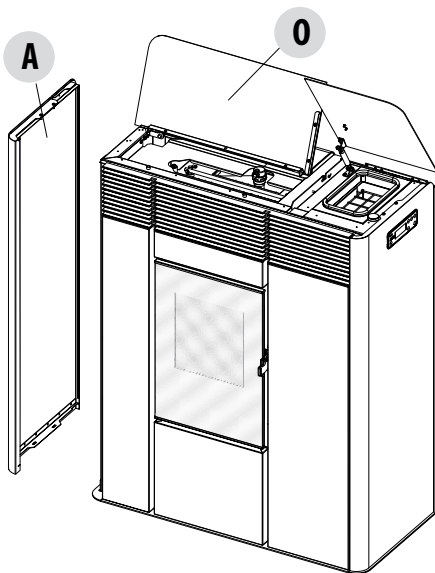



## 7-REMOVAL OF CLADDINGS

In case of maintenance and/or interventions it is possible to remove the front grid "E". Proceed as follows:

- remove the side panels (cladding)
- Remove the two screws "k"
- remove the panel "E"

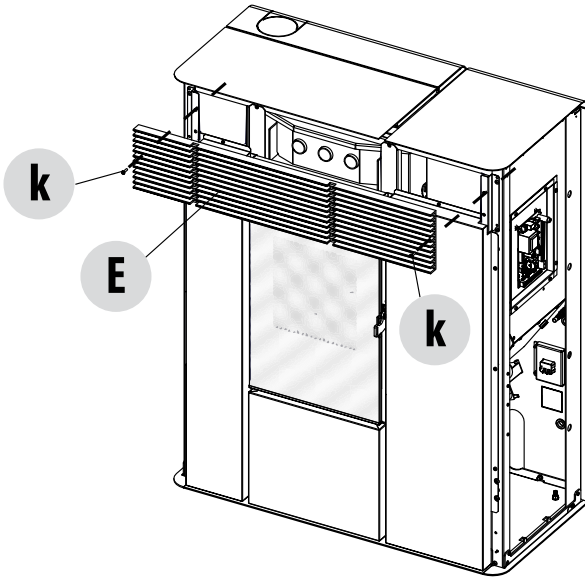

To remove the front right panel "C":

- remove the upper screw "x" from outside the stove
- remove the screw "y" from inside the stove

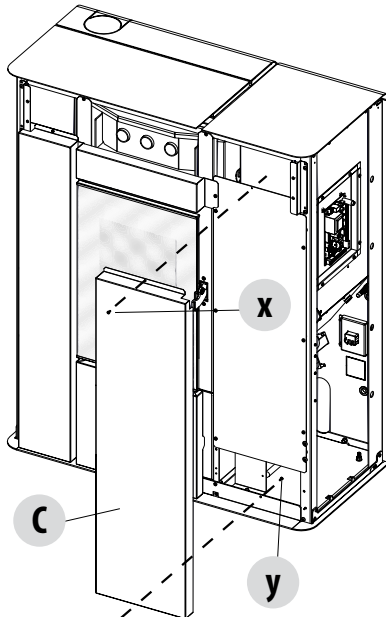

## 7-REMOVAL OF CLADDINGS

To remove the front left panel "F":

- remove the upper screw "x" from outside the stove
- remove the screw "y" from inside the stove

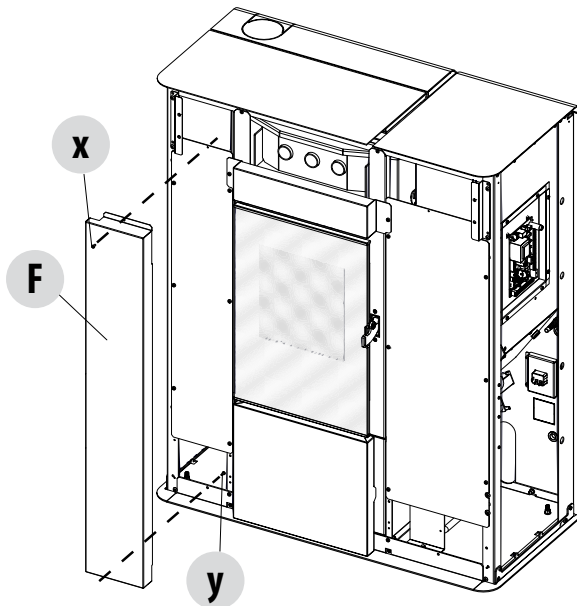

To remove the front top panel "G":

- remove the two screws "x"

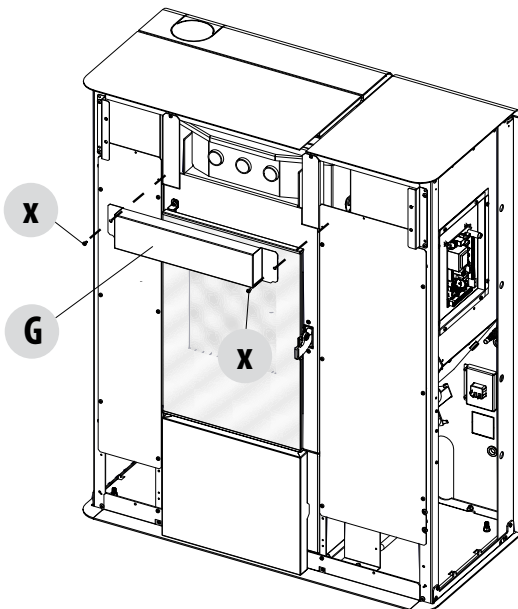

## 7-REMOVAL OF CLADDINGS

### REAR PANEL

If maintenance must be performed on a component of the stove, the rear panel can be removed (if the distances from the walls allow it), otherwise, the maintenance can be performed by removing the side of the stove.

To remove the rear panel, remove the four rear screws "a" and pull panel "L" away.

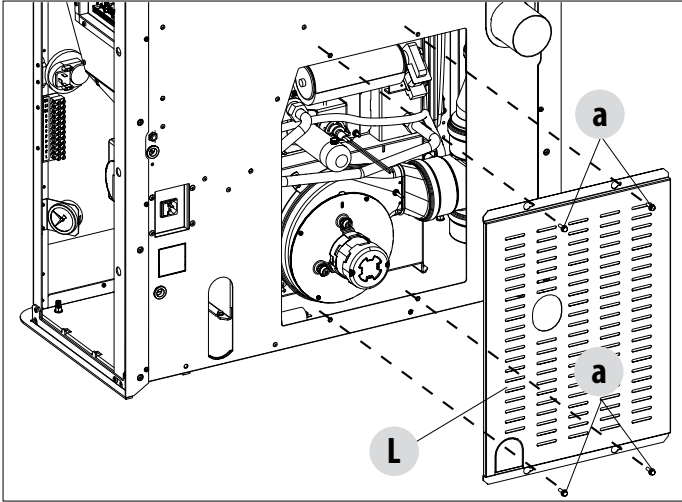

### TERMINAL BLOCK ACCESS PANEL

To perform the terminal block connections, you must remove the right side panel of the ceramic or metal cladding.

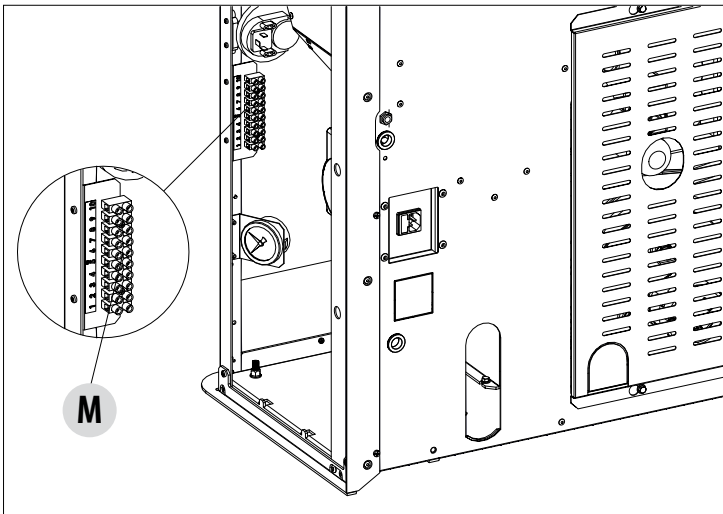

## 8-OPENING THE DOORS

### DOOR OPENING

To open the firebox door "H", insert the cold handle "Z" into the hole in the handle and pull it towards you.



*Attention! Only open the doors when the stove is switched off and cold.*

### FIREBOX DOOR "H"

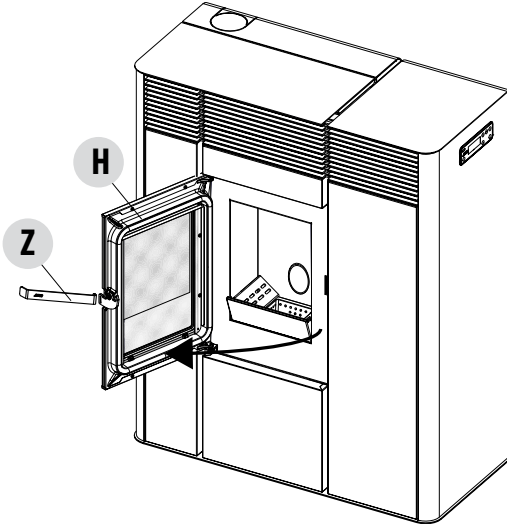

### OPENING LOWER DOOR "Q"

To open the lower door "Q" first of all you must have opened the firebox door "H". Then grip the door "Q" and pull it towards you.

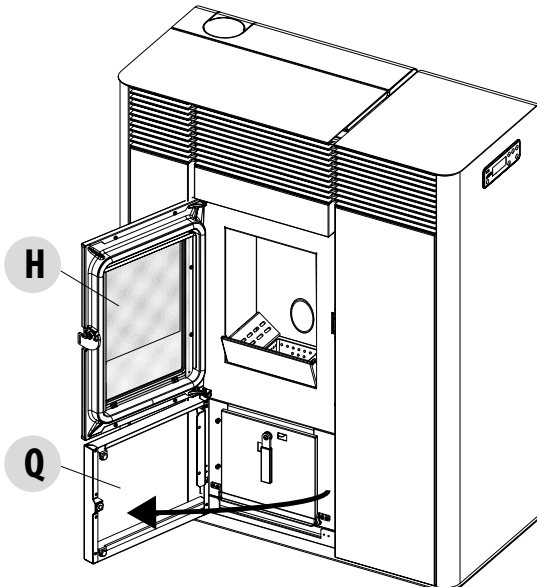

## 8-OPENING THE DOORS

### OPENING FRONT DOOR "O"

To open the door "O" grip it in the part in front of the stove and lift it up.

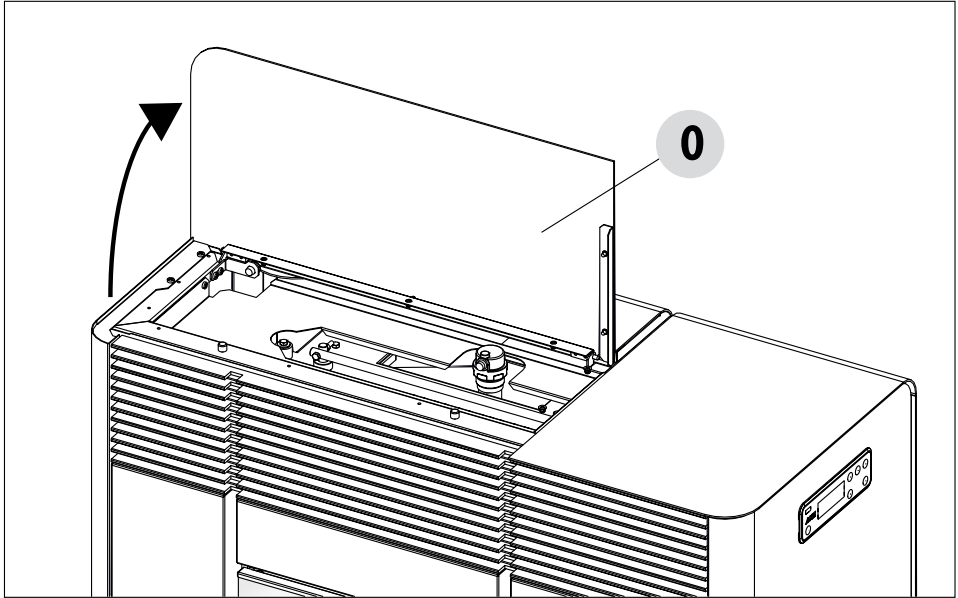

### OPENING PELLET DOOR "D"

To open the door "D" grip it on the side and pull it upwards.

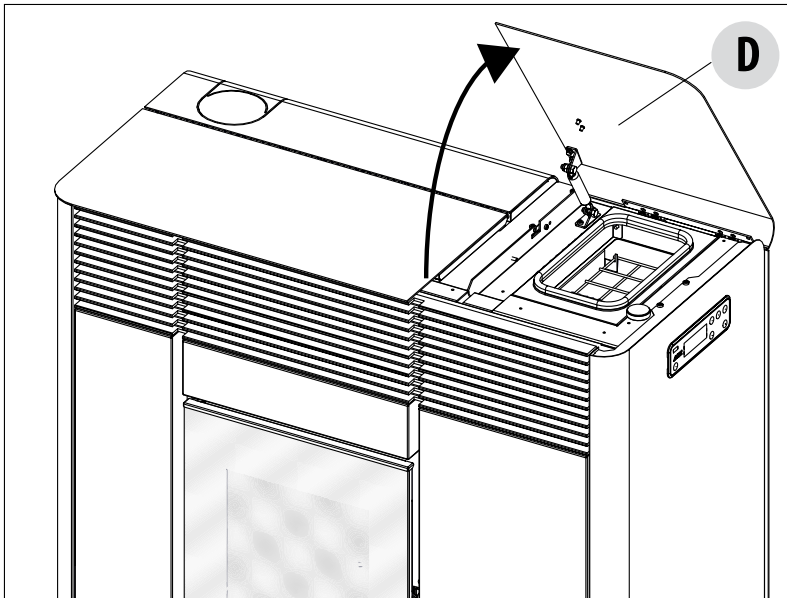

## 9-EASY CONNECT ACCESSORY

### INSTALLATION OF WIFI EASY CONNECT PANEL (OPTIONAL-CODE 4020003)

Remove the knockout hole "M" at the back of the stove to install the WiFi panel "N" and follow the installation instructions found inside the product.

The WiFi panel must be connected to the board on the stove using the supplied cable.

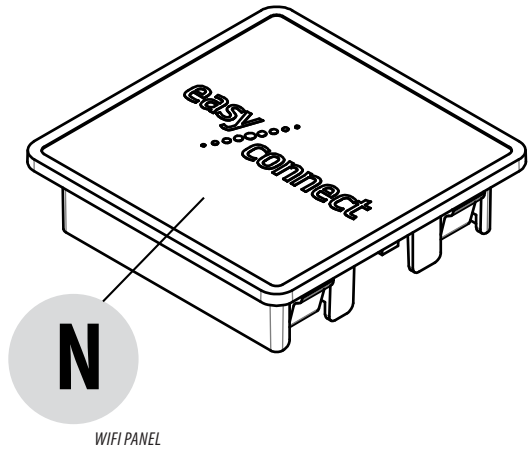
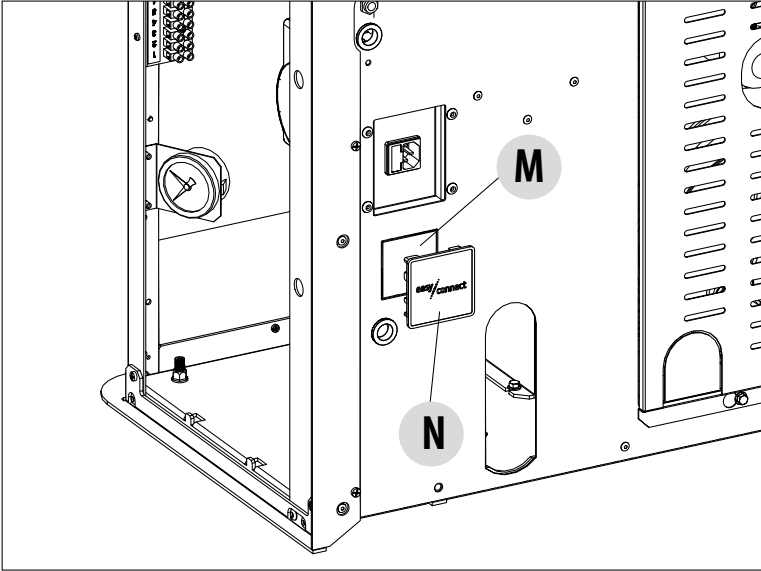

## 10-LOADING THE PELLETS

### LOADING THE PELLETS

Fuel is loaded from the upper part of the stove by lifting the door. Pour the pellets into the tank.

This is easier if performed in two steps:

Pour half of the contents into the tank and wait for the fuel to settle on the bottom.

Then pour in the rest.



***If loading pellets when the stove is running, open the door of the hopper using the stove mitten that comes with the stove itself.***

***When loading, do not let the pellet bag come into contact with hot surfaces.***

***Never remove the protection grid inside the hopper.***

***No other type of fuel other than pellets is to be inserted into the hopper, in compliance with above-mentioned specifications.***

***Store the spare fuel at an adequate safe distance.***

***Do not pour pellets directly onto the brazier but only into the hopper.***

***When the appliance is running and when it is turned off, most of the stove surfaces are very hot (door, handle, glass, smoke outlet pipes, etc.). Therefore it is recommended to avoid coming into contact with these parts.***

LOADING THE PELLETS

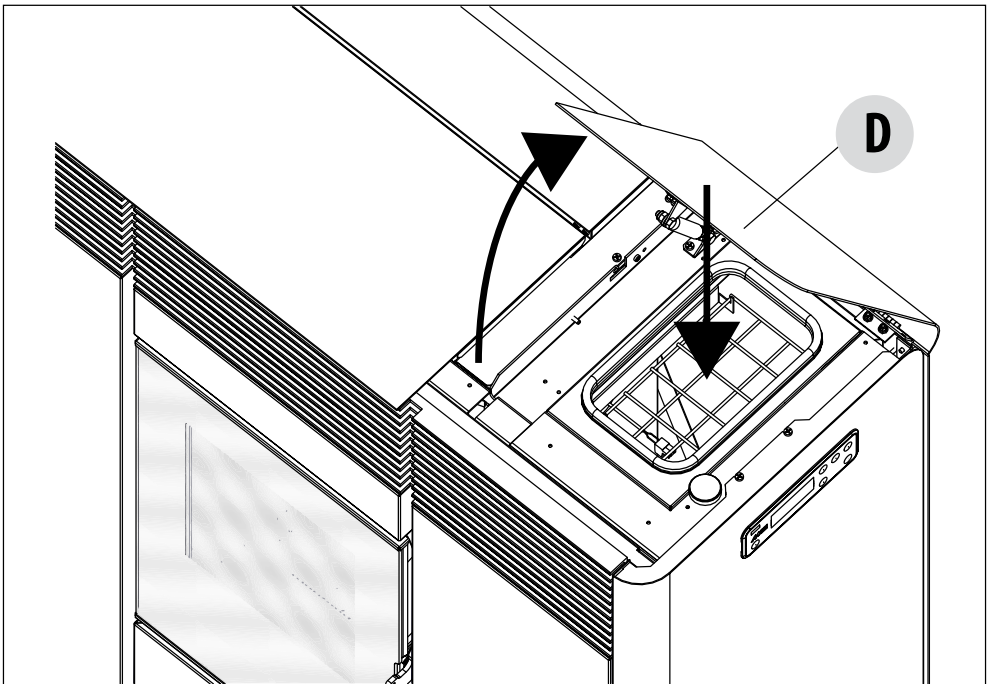

## 11 HYDRAULIC CONNECTION

### SAFETY

**WHAT TO DO IF SMOKE LEAKS INTO THE ROOM OR IN CASE OF EXPLOSION DAMAGING THE DEVICE: SWITCH IT OFF, VENTILATE THE ROOM AND IMMEDIATELY CONTACT THE INSTALLER/TECHNICIAN IN CHARGE OF ASSISTANCE.**

### User Training

**In ALL cases, the technician in charge of installation and first-start-up MUST carry out a thorough handover of the appliance to the owner / end user. The following elements should be covered to the satisfaction of the end user. Failure to do this may result in unsafe use of the appliance:**

- Explanation of the appliance and how it works
- Necessity to maintain ventilation to the appliance and the issues that may arise otherwise
- Fuel usage and supply
- How to light the appliance safely
- What to do in the event of failed ignitions
- What to do in the event of alarms (in particular those triggered when the appliance runs out of fuel)
- How to maintain the appliance correctly and the importance of carrying out these tasks each month
- It is good practise to agree a date for the first annual servicing
- Discuss the use of secondary heating systems if applicable
- Explain how the remote control or room stats operate and their optimal positioning



# 11 HYDRAULIC CONNECTION

## PLUMBING SYSTEM CONNECTION



### IMPORTANT!

The connection of the stove to the plumbing system must be carried out **ONLY** by specialised personnel who are capable of carrying out installation properly in compliance with current standards in the country of installation. The manufacturer will not be held responsible for damage to persons or property in the event of failed operation if the aforementioned warning is not complied with.

## CONNECTION DIAGRAM FOR ONLY HEATING STOVE

- A1 Heating water supply 3/4" M
- A2 Heating water return 3/4" M
- A3 System filling 1/2"
- A4 System outlet 1/4" M (see image on next page)

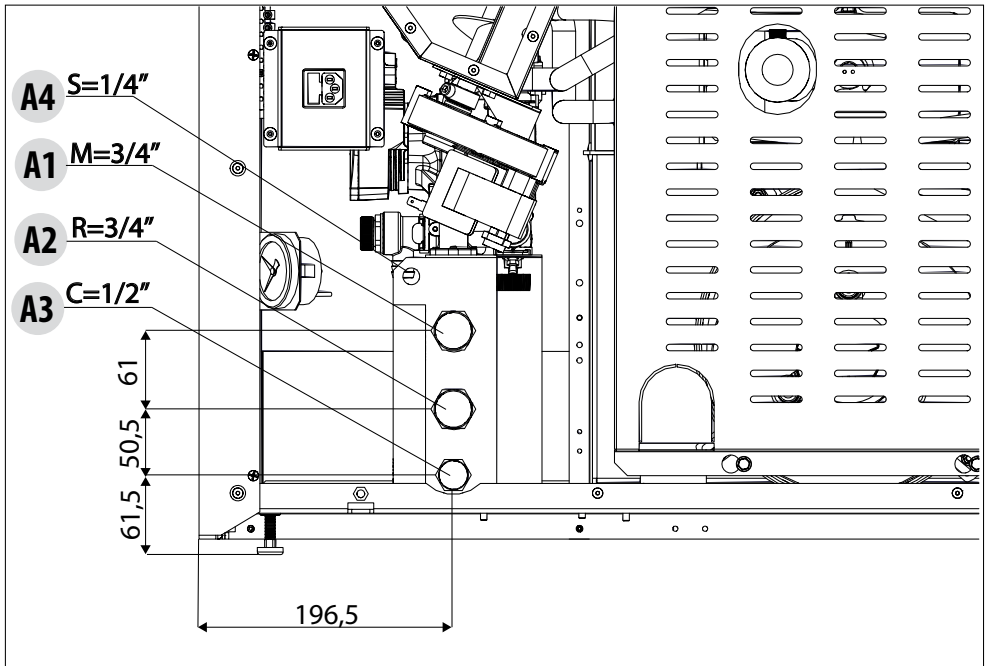

### IMPORTANT!!!

**CLEAN THE ENTIRE SYSTEM BEFORE CONNECTING THE STOVE, IN ORDER TO REMOVE ALL RESIDUE AND DEPOSITS.**



Always install shutters in the system leading to the stove so as to disconnect it from the hydraulic system should it be necessary to move it, or when it requires routine and/or special maintenance.

Connect the stove using flexible pipes so that the stove is not excessively constrained to the system, and to allow slight movements.

## 11 HYDRAULIC CONNECTION

### DISCHARGE VALVE 3 bar

The safety valve that can be inspected is found on the right side of the stove, under the pump. A high resistance pipe is connected, as per standard, to the safety discharge to drain the water until the bracket of the hydraulic connections. From that point, it is MANDATORY to connect a rubber hose that can withstand a temperature of 110°C (not supplied) and that reaches the outside for any water outlet.



*The manufacturer of the appliance is not liable for any flooding caused by the safety valves being triggered if these have not been joined properly to the outside of the product and to a proper collection and evacuation system.*

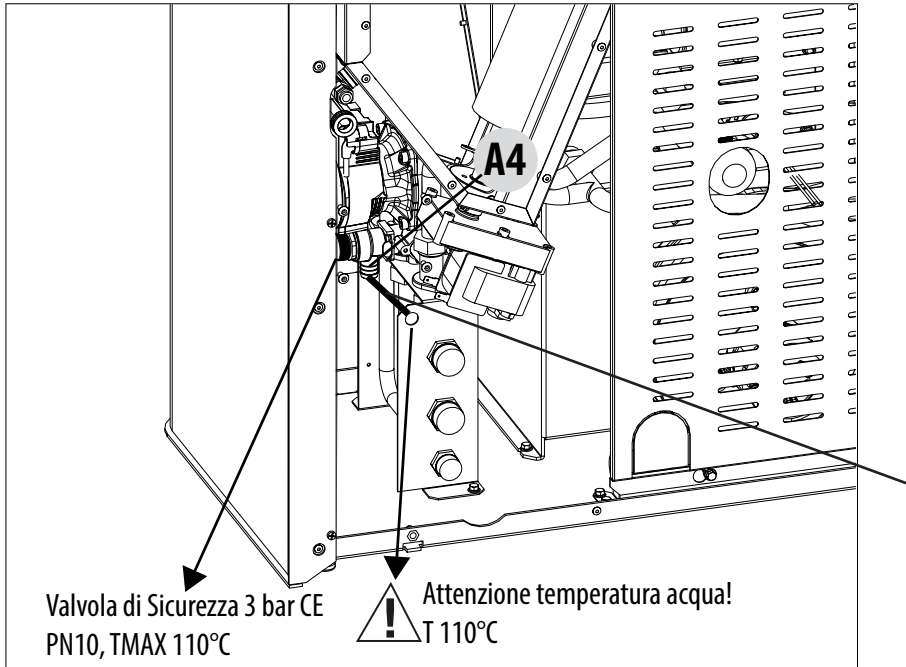

Connection to water drain valve  
(as per standard on stove)

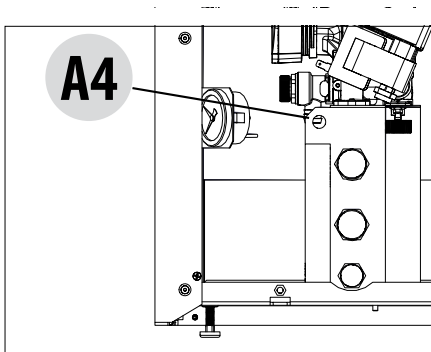

A4 System outlet 1/4" M

## 11 HYDRAULIC CONNECTION

### CONNECTING THE SYSTEM

Make the connections to the corresponding fittings shown in the diagram on the previous page. Make sure the pipes are not placed under tension or undersized.



**IT IS STRONGLY RECOMMENDED TO WASH THE ENTIRE SYSTEM BEFORE CONNECTING THE STOVE IN ORDER TO GET RID OF RESIDUES AND DEPOSITS.**

**Always install shutters in the system leading to the stove so as to disconnect it from the hydraulic system should it be necessary to move it, or when it requires routine and/or special maintenance. Connect the stove using flexible pipes so that the stove is not excessively constrained to the system, and to allow slight movements.**

**The pressure discharge valve (C) is always connected to a water drain pipe. The pipe must be adequate to support the water's high temperature and pressure.**

### CLEANING THE SYSTEM

It is mandatory for the connections to be easy to disconnect by way of unions with rotating connections.

Install suitable shutters to cut off the tubes from the heating system. Assembling the safety valve on the system is compulsory.

In order to protect the heating system from damage caused by corrosion, incrustation or deposit build-up, it is important to clean the appliance before installation, using suitable products, in compliance with Standard UNI 8065 (water treatment of thermal plants for civil use).

The use of FERNOX PROTECTOR F1 product (available at our authorised centres) is recommended, this provides long-term protection of heating systems against corrosion and calcium build-up. It prevents the corrosion of the metal parts of the appliance, i.e. the ferrous metals, copper and copper and aluminium alloys. It also reduces the noise produced by the stove. Refer to the instructions on the product. Cleaning should be performed by a qualified technician.

We also recommend the use of FERNOX CLEANER F3 and LEAK SEALER F4, always available from our authorised distribution centres.

FERNOX F3 is a neutral product for rapid and efficient cleaning of heating appliances. It has been designed to eliminate residues, oily deposits and incrustations from existing appliances of all ages. It can help restore the heating efficiency of the stove and reduce the noise it generates.

FERNOX F4 is intended to be used with all heating appliances to seal micro fractures that cause small and inaccessible leaks.

### FILLING THE SYSTEM

To fill the system, the stove can be equipped with an end piece (optional) with a non-return valve **(D)** for manual filling of the heating system (if the optional is not installed, the filling tap on the main stove will be used). During this operation, any air in the system is released from the automatic vent valve located under the top.

To ensure the valve vents, it is advisable to loosen the grey cap one turn and leave the red cap blocked (see figure). Set the filling pressure of the system **WHEN COLD** to **1 bar (100 kPa)**. During operation, if the system pressure drops (due to evaporation of dissolved gases in the water) to values lower than the minimum indicated above, the user must use the filling tap to bring the pressure back up to its normal pressure.

To ensure correct stove operation, the maximum pressure in the system **WHEN HOT** must not exceed **1.5 bar (150 kPa)**.



**Fit the system with a 2 bar safety valve connected to an accessible outlet.**

**To monitor the system pressure, the terminal (optional) is equipped with a pressure gauge (M).**

Upon completion of this operation, always close the tap.



**It is normal to hear noises and gurgling until all the air in the system is released.**

## 11 HYDRAULIC CONNECTION

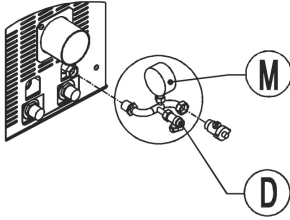

END PIECE WITH A FILLING TAP (D) AND PRESSURE GAUGE (M) (ACCESSORY)

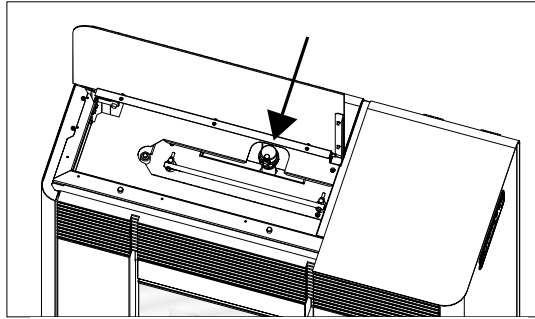

MANUAL VENT VALVE UNDER THE TOP

### WATER CHARACTERISTICS

The characteristics of the water used to fill the system are very important to prevent the build-up of mineral salts and the formation of incrustations along the pipes, in the stove and in the heat exchangers.

Therefore, please **GET YOUR PLUMBER'S ADVICE CONCERNING:**

- **Hardness of water circulating in the system, to prevent problems of incrustation and limescale, especially in the domestic water heat exchanger (> 25° French).**
- **Installation of a water softener (if water hardness exceeds 25° French).**
- **Filling the system with treated water (demineralised).**
- **Possibly providing an anti-condensation circuit.**
- **Installation of plumbing bumpers to prevent the phenomenon known as "water hammer" from occurring along the fittings and pipes.**

For those who have very extensive systems (with large amounts of water) or which require frequent refilling, to install water softening systems.



***It should be remembered that incrustations drastically reduce performance due to low thermal conductivity.***

## 12-ELECTRICAL CONNECTION

### ELECTRICAL CONNECTION

First connect the power cable to the back of the stove and then to a wall socket.



*It is recommended to disconnect the power cable when the stove is not used.*

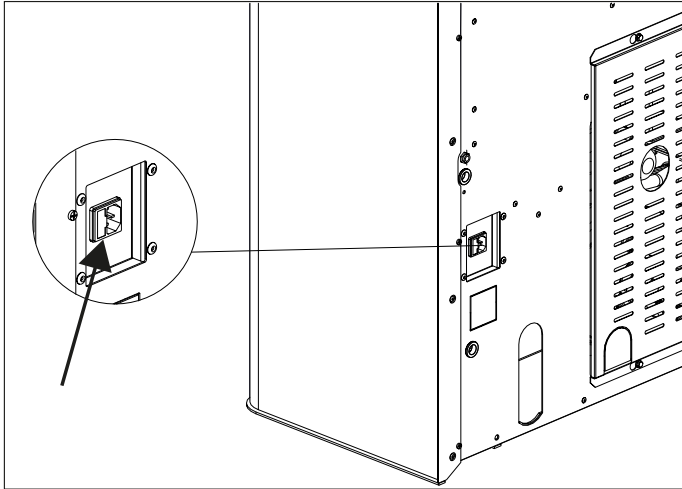

ELECTRICAL STOVE CONNECTION



*The cable must never come into contact with the smoke exhaust pipe or any other part of the stove.*

### STOVE POWER SUPPLY

Connect the power cable to the back of the stove and then to a wall socket. The stove is then powered.

There is a fuse box also in the switch block next to the power socket. Open this compartment by simply lifting the cover, using a screwdriver as a lever from inside the power outlet compartment. Inside there are two fuses (5x20 mm T delayed / 3.15 A 250 V), which may need to be replaced if the stove is not powered (e.g. the control panel display does not light up) - operation to be implemented by an authorised and skilled technician.

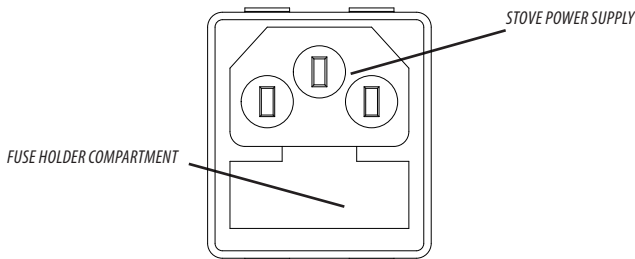

#### **ATTENTION!**

*All cleaning and / or replacement of parts must be carried out with the electric plug disconnected.  
Disconnect the product from the 230V power supply before performing any maintenance operations.  
If the cable is damaged, replace it.*







Via La Croce n°8  
33074 Vigonovo di Fontanafredda (PN) – ITALY  
Telephone: 0434/599599 a.s.  
Fax: 0434/599598  
Internet: [www.mcz.it](http://www.mcz.it)  
e-mail: [mcz@mcz.it](mailto:mcz@mcz.it)