



SEALED PELLETT STOVE

SUITE-CLUB-MUSA Hydromatic 18 M2
SUITE-CLUB-MUSA Hydromatic 24 M2
SUITE-CLUB Hydromatic 24 ACS M2

PART 1 - REGULATIONS AND ASSEMBLY

Translation of original instructions

MCZ

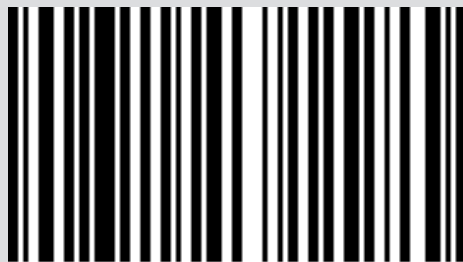

8902137501

TABLE OF CONTENTS

TABLE OF CONTENTS	II
INTRODUCTION	1
1-WARNINGS AND WARRANTY CONDITIONS	2
2-INSTALLATION	11
3-DRAWINGS AND TECHNICAL SPECIFICATIONS	19
4-UNPACKING.....	28
5-SUIT/CLUB STOVE ASSEMBLY	32
6-MUSA STOVE ASSEMBLY	47
7-REAR PANEL	54
8-DOOR OPENING	55
9-LOADING THE PELLETS	56
10-HYDRAULIC CONNECTION	58
11-ELECTRICAL CONNECTION.....	63

INTRODUCTION

Dear Customer,

Our products are designed and manufactured in accordance with standards in force, with high quality materials and using our extensive experience in the transformation processes.

To get the best performance, we suggest you read the instructions in this manual carefully.

This installation guide is an integral part of the product: ensure that the manual is always supplied with the appliance, even if it changes owner. If the manual is lost, you can request another copy from the local Technical Dept. or download it directly from the company's website.

All local regulations, including those referring to national and European standards, must be observed when installing the appliance.

In Italy, for the installation of systems with a biomass below 35KW, refer to the Ministerial Decree 37/08 and the qualified installation technician with the suitable requirements must issue a certificate of compliance for the system installed. (By system we intend Stove+Flue+Air inlet).

REVISIONS TO THE PUBLICATION

The content of this manual is strictly technical and the property of MCZ Group Spa.





No part of this manual may be translated into other languages, adapted and/or reproduced, even in part, in other mechanical and/or electronic form or media, for photocopies, recordings or other, without the prior written authorisation of MCZ Group Spa.

The company reserves the right to make changes to the product at any time without prior notice. The owner company reserves its rights according to law.

CARE OF THE MANUAL AND HOW TO CONSULT IT

- Take care of this manual and store it in an easily and quickly accessible place.
- Should this manual be lost or destroyed, request a copy from your retailer or directly from the authorised Technical assistance department. It can also be downloaded from the company's website.
- "**Bold text**" requires special attention.
- "*Text in italics*" is used to draw attention to other paragraphs in the manual or for any additional clarifications.
- "Note" provides the reader with additional information.

SYMBOLS USED IN THE MANUAL

	ATTENTION: carefully read the relative message as failure to comply with the information provided may result in serious damage to the product and danger to the persons who use it.
	INFORMATION: failure to comply with these provisions will compromise use of the product.
	OPERATING SEQUENCES: sequence of buttons to be pressed to access the menus or perform adjustments.
	MANUAL carefully read this manual or the relative instructions.



SAFETY WARNINGS

- **The installation, electrical connection, operating test and maintenance must only be carried out by a qualified operator.**
- **Install the product in compliance with the laws and regulations in force.**
- Only use the fuel recommended by the manufacturer. The product must not be used as an incinerator.
- It is strictly forbidden to use alcohol, petrol, liquid fuel for lanterns, diesel, bio-ethanol, fluids for lighting charcoal or similar liquids to light/rekindle the flame in these devices. Keep these flammable liquids well away from the appliance when in use.
- Do not put any fuel other than wood pellets in the hopper.
- The instructions provided in this manual must always be complied with to ensure the product and any electronic appliances connected to it are used correctly and to prevent accidents.
- **This appliance can be used by children aged 8 years and above and persons with reduced physical, sensory or mental capabilities or lack of experience and knowledge provided they are supervised or have been given instructions regarding use of the appliance in a safe way and understand the hazards involved. Children must not play with the appliance. Cleaning and maintenance to be performed by the user must not be carried out by children without supervision.**
- The user, or whoever is operating the product, must read and fully understand the contents of this installation guide before performing any operation.
- The user can only make a significant contribution to the eco-friendly operation of the heat generator if all requirements set out in the operating instructions are met.
- Dispose of combustion ash in accordance with current laws.
- Do not climb on or lean on the product.

1-WARNINGS AND WARRANTY CONDITIONS

- Do not dry laundry on the product. Any drying racks or the like must be kept at a safe distance from the product. **Fire hazard.**
- The product maintenance operations must be exclusively carried out by a qualified operator on a yearly basis.
- A non-compliant or improper/lack of maintenance of the product can cause hazardous situations and/or irregular operation.
- The manufacturer is relieved of any civil and criminal liability for damage caused by improper use and/or modification/tampering with the product and/or its accessory.
- We do not recommend waiting for the parts to get worn out before having them replaced.
- Only use original spare parts. The retailer, service centre or qualified personnel can provide all necessary information regarding spare parts.
- Many surfaces of the product get very hot (door, handle, glass, smoke outlet pipes, etc.). **Avoid coming into contact with these parts without adequate protective clothing or suitable equipment, such as gloves with thermal protection or “cold handle” operating systems.**
- **It is forbidden to operate the product with the door open or the glass broken. During operation, all the doors provided on the product must remain closed, with the exception of the one on the hopper which can be opened temporarily and only for the time required for topping up the fuel.**
- **The doors/covers on the appliance must remain closed when it is not being used.**
- The product must be electrically connected to a properly earthed system.
- Switch the product off in the event of a fault or malfunction.
- **Accumulated unburnt pellets in the brazier after each “failed ignition” or abnormal emptying of the pellet hopper must be completely removed before lighting again. Always check that the brazier is clean and positioned properly before lighting the product again.**

1-WARNINGS AND WARRANTY CONDITIONS

- Do not allow the product to come into contact with water, it contains live electrical parts.
- Do not wash the product with water (or other liquids) as they could penetrate inside the unit, damaging the electrical insulation with the risk of electrocution.
- Do not use detergents to wash the stove, they could damage the aesthetic parts of the product.
- Do not stand for a long time in front of the product in operation. Do not overheat the room you are in and where the product is installed. This may harm one's physical conditions and cause health problems.
- Install the product in rooms that do not pose a fire hazard and are equipped with power and air supplies and smoke outlets.
- In the event of fire in the chimney, turn off the device, disconnect it from the mains and do not open the door whatsoever. Then contact the competent authorities.
- The product and the cladding must be stored in a dry place and must not be exposed to weathering.
- It is recommended not to remove the feet that support the product in order to ensure adequate insulation, especially if the flooring is made of flammable materials.
- Assess the static conditions of the surface on which the weight of the product will rest and provide suitable insulation if it is made of flammable material (e.g. wood, fitted carpet or plastic).
- In the event of a malfunction of the ignition system, do not force it on by using flammable materials.
- **It is forbidden to manually load the fuel into the brazier. Failure to follow this warning can lead to hazardous situations.**

1-WARNINGS AND WARRANTY CONDITIONS

- The sound pressure level of this appliance does not exceed 70 dB(A).
- **Live electrical parts: only power the product once it has been fully assembled.**
- **Disconnect the product from the 230V power supply before performing any maintenance operations. The plug must be removed in such a way that an operator can verify from any point to which he/she has access, that the plug remains unplugged.**

1-WARNINGS AND WARRANTY CONDITIONS

INFORMATION:

- Please contact the retailer or qualified personnel for any information, problem or malfunction.
- Only use the fuel specified by the manufacturer.
- When the product is switched on for the first time, it is normal for it to emit smoke due to the paint heating up for the first time. Therefore make sure the room it is installed in is well-ventilated.
- Periodically check and empty the inspectionable parts of the smoke duct (e.g. Tee fitting caps)
- Have the smoke outlet system periodically checked and cleaned
- The product is not a cooking appliance.
- Always keep the cover of the fuel hopper closed.
- Store this installation and user manual with care as it must accompany the product for the duration of its useful life. If the product is sold or transferred to another user, always ensure the manual is also handed over.

INTENDED USE

The product only works with wood pellets and must be installed inside a room.

PRODUCT PERFORMANCE CHECKS.

All our products undergo ITT TESTS carried out by a notified third party laboratory (system 3) and in accordance with Regulation (EU) number 305/2011 "Construction products", according to standard EN 14785:2006 for household appliances and "Machinery Directive" EN 303-5 for boilers.

In the case of tests for any market surveillance or inspections by third parties, please consider the following warnings:

- To reach the declared performance levels, the product must perform an operating cycle of at least 15-20 hours beforehand.
- Set the average draught of the combustion fumes as specified in the "technical product features" table
- The type of pellets used must comply with the current EN ISO 17225-2 class A1 regulation. Fir pellets are usually used for certification.
- The amount of thermal energy can vary according to the length and calorific value of the fuel. This may require some adjustments (accessed from the user menu) to comply with the hourly consumption specified in the "technical product features" table. Using class A1 pellets guarantees a calorific value that is likely to be close to that used in the product certification; the size of the pellet grains can significantly affect hourly fuel loading and consequently performance; it is therefore suggested to use pellets with a 6 mm diameter and an average length of around 24 mm (avoid pellets that are too long or excessively crushed).
- With wood-burning appliances, the fuel must comply with the current EN ISO 17225-5 class A1 regulation. Check the correct moisture of the fuel, as it must be within the range of 12 - 20% (it is best if the moisture is close to 12%, as is normally used in certification). As the fuel moisture increases, different combustion air settings are required, which are implemented from the combustion air register, thereby modifying the mixture of primary and secondary air
- It is important to check the operation of devices that can affect performance (for example air fans or electric safety devices) in case of damage due to handling.
- Nominal performance has been obtained by setting the maximum flame power and room ventilation in **manual** mode. Performance at reduced power was achieved at minimum flame and ventilation power (P1 and V1) in manual mode. The other conditions correspond to intermediate ventilation and power.
- If a "verification" mode is provided in the menu, set this function during the readings to ensure that no temperature modulation occurs due to an incorrect setting of the operating parameters.
- Lastly, strictly comply with the sampling points specified in the regulations in terms of emissions as well as temperature

1-WARNINGS AND WARRANTY CONDITIONS

WARRANTY CONDITIONS

For the duration, terms, conditions, limitations of the MCZ conventional warranty, please refer to the specific warranty card that is included with the product.

Information for management of waste electrical and electronic equipment containing batteries and accumulators



This symbol appears on the product, on the batteries, on the accumulators or on their packaging or on their documentation; it indicates that the product and the batteries or the accumulators included must not be collected, recycled or disposed of with household waste at the end of their service life.

Improper management of waste electrical and electronic equipment, batteries or accumulators can cause the hazardous substances contained within to leak out. In order to avoid harming the environment or health, the user is required to separate this equipment, and/or the batteries or accumulators included, from other types of waste and deliver them to the local collection centre. The distributor can be asked to collect the waste electrical and electronic equipment under the conditions and according to the procedures laid down by Legislative Decree 49/2014.

Separate collection and correct treatment of waste electrical and electronic equipment, batteries and accumulators contribute to conserving natural resources, respect for the environment and ensure the protection of health.

For more information on collection centres for waste electrical and electronic equipment, batteries and accumulators, contact the competent public Authorities for issue of the authorisations.

1-WARNINGS AND WARRANTY CONDITIONS

WARNINGS FOR THE CORRECT DISPOSAL OF THE PRODUCT

The owner is the sole party responsible for demolishing and disposing of the product. This must be performed in compliance with laws related to safety and environmental protection in force in his/her country.

At the end of its working life, the product must not be disposed of as urban waste.

It must be taken to a special differentiated waste collection centre set up by the local authorities or to a retailer that provides this service. Separating and recycling prevents potential negative effects on the environment and health (often caused by inappropriately disposing of product parts). It also allows materials to be recovered in order to obtain significant savings in energy and resources.

The following table and the exploded view it refers to highlight the main components that can be found in the device and indications on how to separate and dispose of them correctly when no longer used.

More specifically, the electric and electronic components must be separated and disposed of in authorised centres, in compliance with the WEEE directive 2012/19/EU and the relative national transpositions.

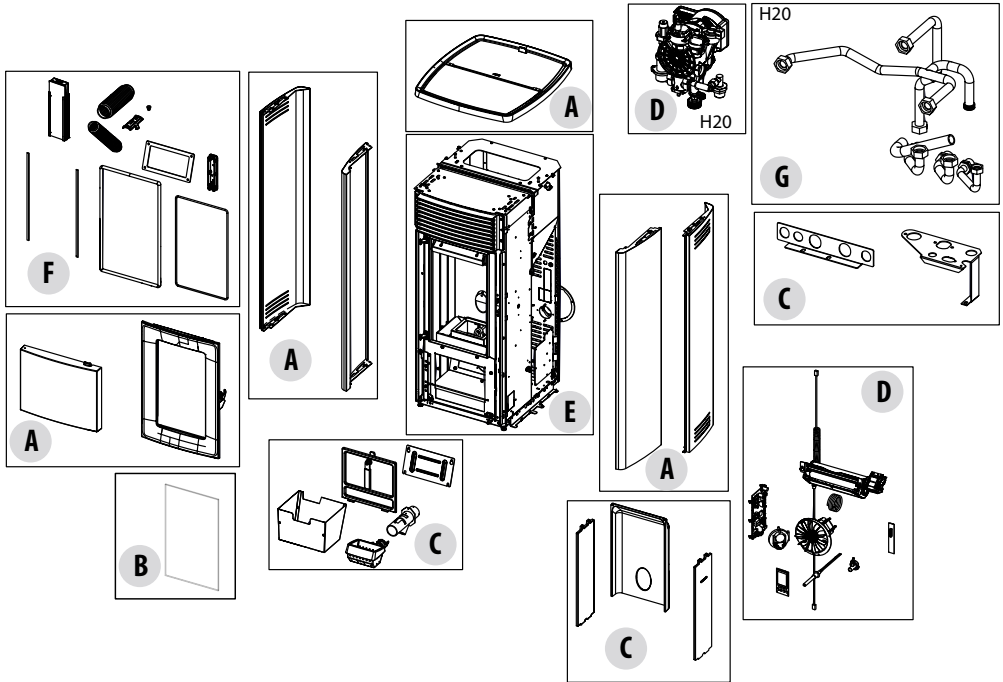

1-WARNINGS AND WARRANTY CONDITIONS

LEGENDA	WHERE TO DISPOSE	MATERIALS
<p style="text-align: center;">A OUTER CLADDING</p>	If there is any, to be disposed of separately based on the material used:	Metal
		Glass
		Tiles or ceramics
		Stone
<p style="text-align: center;">B GLASS DOORS</p>	If there is any, to be disposed of separately based on the material used:	Glass ceramic (fire door): to be disposed of with inert or mixed waste
		Tempered glass (oven door): to be disposed of with glass
<p style="text-align: center;">C INTERIOR CLADDING</p>	If there is any, to be disposed of separately based on the material used:	Metal
		Refractory materials
		Insulating panels
		Vermiculite
<p style="text-align: center;">D ELECTRIC AND ELECTRONIC COMPONENTS</p>	To be disposed of separately in authorised centres, as indicated in the WEEE directive 2012/19/EU and the relative national transposition.	Wiring, motors, fans, circulators, display panels, sensors ignition plug, electronic cards, batteries.
<p style="text-align: center;">E METAL STRUCTURE</p>	To be disposed of separately with metal	
<p style="text-align: center;">F COMPONENTS THAT CANNOT BE RECYCLED</p>	To be disposed of with mixed waste	E.G.: Gaskets, rube piping, silicone or fibres, plastic.
<p style="text-align: center;">G HYDRAULIC COMPONENTS</p>	<i>Piping, fittings, expansion vessel, valves. If there are any, to be disposed of separately based on the material they are made of:</i>	Copper
		Brass
		Stainless steel
		Other materials

1-WARNINGS AND WARRANTY CONDITIONS

Our solid bio-combustible products, (hereinafter called "Products") are designed and manufactured in compliance with one of the following European standard harmonised to Regulation (UE) no. 305/2011 for construction products:

EN 14785: "Residential space heating appliances fired by wood pellets"

EN 13240: "Room heaters fired by solid fuel."

EN 13229: "Inset appliances including open fires fired by solid fuels"

EN 12815: "Residential cookers fired by solid fuel"

The products also comply with the essential requirements of Directive **2009/125/EC (Eco Design)** and, where applicable, Directives:

2014/35/EU (LVD - Low Voltage directive)

2014/30/EU (EMC - Electromagnetic Compatibility directive)

2014/53/EU (RED – Radio Equipment directive)

2011/65/EU (ROhS)

Having specified the above, we highlight and report that:

- **This manual and technical data sheet, also available on our website**, bear all of the specific indications and necessary and essential information to choose the product, to install it correctly and to properly size the smoke expulsion system;
- the Products must be **installed, controlled and serviced** by a qualified operator, according to the instructions in this manual and in compliance with the laws and installation and maintenance standards in force in individual countries, so as to provide an efficient heating system, properly sized according to the needs of the home;
- **if the Products are thermally stressed**, constantly operating for several hours at high power (e.g. 3, 4 hours a day at outputs P4 or P5), we recommend more frequent cleaning and reducing the interval between routine maintenance operations according to the operating condition of the product. We furthermore point out that these operating conditions increase the risk of premature wear of the product, especially those parts exposed to the direct heat of the fire (e.g. combustion chamber), the original condition of which can undergo modifications and deterioration which, among other things, could generate noise during operation of the unit due to mechanical expansion.

The manufacturer will not be held liable if the above information is ignored.

2-INSTALLATION



The instructions in this chapter refer explicitly to the Italian installation regulation UNI 10683. In any case, always observe the regulations in force in the country of installation.

PELLETS

The pellet is obtained from natural dried wood sawdust (without paint). The compactness of the material is guaranteed by the lignin contained in the wood itself, without glue or binders.

The market offers different types of pellets with characteristics that vary according to the wood mixtures. The most common diameter on the market is 6 mm (although 8 mm diameter is also available) with a length, on average, between 3 and 40 mm. A good quality pellet has a density of between 600 and 750 or more kg/cubic metres and a moisture content that accounts for 5 to 8% of its weight.

Pellets have technical advantages besides being an ecological fuel, as the wood residue is used completely, thereby achieving cleaner combustion than that of fossil fuels.

While good-quality wood has a calorific value of 4.4 kW/kg (15% moisture, after about 18 months of seasoning), that of pellets is around 4.9 kW/kg. To ensure good combustion, the pellets must be stored in a dry place and protected from dirt. Pellets are usually supplied in 15 kg bags, therefore, storing them is very convenient.

Good quality pellets guarantee good combustion, thereby decreasing harmful emissions into the atmosphere.



15 Kg BAG OF PELLETS



The poorer the quality of the fuel, the more often the internal parts of the brazier and combustion chamber need to be cleaned.

The main quality certifications for pellets currently available on the European market guarantee that the fuel complies with class A1/A2 according to ISO 17225-2. These certifications include, for example, ENPlus, DINplus, Ö-Norm M7135, and specifically assure that the following characteristics are complied with:

- calorific value: 4.6 - 5.3 kWh/kg.
- Water content: $\leq 10\%$ of the weight.
- Percentage of ash: max 1.2% of the weight (A1 less than 0.7%).
- Diameter: $6\pm 1/8\pm 1$ mm.
- Length: 3-40 mm.
- Content: 100% untreated wood without the addition of binding agents.



The company recommends using certified fuel for its products (ENPlus A1, DINplus, Ö-Norm M7135).

The use of pellets that do not comply with the characteristics specified previously may compromise the operation of your product and therefore invalidate the warranty and product liability.

2-INSTALLATION

FOREWORD

The heating system (generator + combustion air supply + combustion product expulsion system + any hydraulic/aerualic system) must be installed in compliance with the laws and regulations in force¹, and carried out by a qualified technician, who must issue a declaration of conformity of the system to the system manager and shall undertake full responsibility for final installation and consequent good operation of the product.

The manufacturer declines all responsibility in the event of installations that do not comply with the laws and regulations in force and inappropriate use of the appliance.

In particular one must ensure that:

- the environment is suitable for installing the appliance (floor load-bearing capacity, presence or possibility of creating an adequate electrical/hydraulic/aerualic system when required, volume compatible with the appliance characteristics, etc.);
- the appliance is connected to a smoke expulsion system correctly sized according to EN 13384-1, which is resistant to soot fire and which complies with the distances prescribed by the combustible materials indicated on the plate data;
- there is a suitable combustion air flow to the appliance;
- other combustion appliances or extraction devices installed do not cause a negative pressure of more than 4 Pa in the room where the product is installed compared to the outside (only sealed appliances are allowed a maximum of 15 Pa of negative pressure in the room).

¹The national reference standard for the installation of domestic appliances is UNI 10683 (IT) - DTU NF 24.1 (FR) - DIN 18896 (DE) - NBN B 61-002 (BE) - Real Decreto 1027/2007 (ES)

In particular, it is recommended to strictly observe the safety distances from combustible materials to avoid serious harm to people and to the integrity of the home.

Installation of the appliance must ensure easy access to service the appliance itself, the smoke channels and the flue.

Always maintain adequate distance and protection in order to prevent the product from coming into contact with water.

It is forbidden to install the stove in rooms with a fire hazard.

With the exception of sealed installations, it is also forbidden for liquid fuel appliances with continuous or intermittent operation that draw the combustion air from the room they are installed in or B-type gas heating appliances, with or without the production of domestic hot water, to coexist in the same room or in interconnecting rooms.



Sealed installation means that the product is certified as sealed and its installation (ducting of the combustion air and connection to the chimney) is airtight with respect to the installation environment.

A sealed installation does not consume the room's oxygen but draws all the air from the outer environment (if suitably ducted) and makes it possible to install the product, therefore, it can be installed in all houses that require a high degree of insulation such as "passive" or "high energy efficiency" houses. Thanks to this technology there is no risk of smoke emissions in the room, hence no air inlets and relevant ventilation grilles are required in the installation premises.

Consequently, there will be no more draughts of cold air in the room, which would otherwise make it less comfortable and reduce the overall efficiency of the system. The sealed stove may even be installed in a sealed installation that is compatible with the presence of forced ventilation or in premises that might have negative pressure with respect to the outside.

2-INSTALLATION

MINIMUM DISTANCES

Observe the distances from flammable objects (sofas, furniture, wood panelling, etc..) as specified in the following diagram.

If objects considered to be particularly sensitive to heat are present, such as furniture, curtains or sofas, as a precaution, increase the stove clearances substantially to avoid possible deterioration due to the effect of heat.

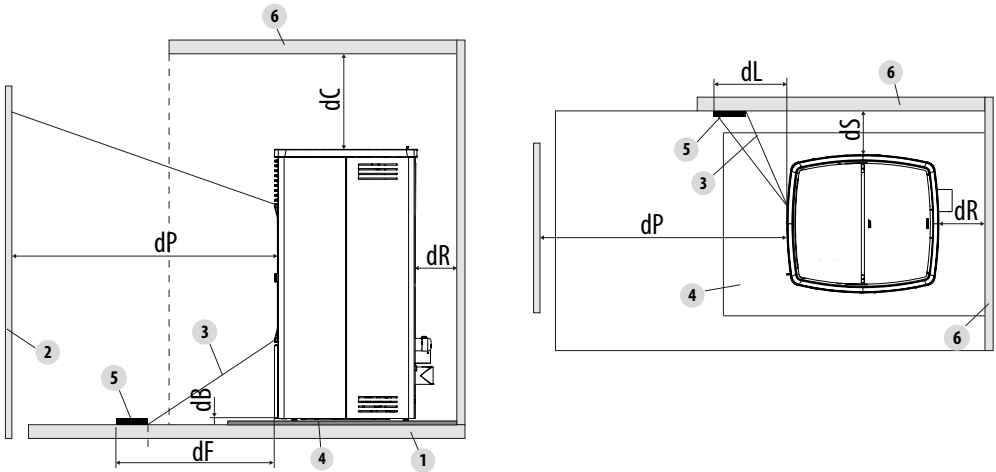

	Safety distance from combustible material (mm)
dR (rear distance)	200
dS (side distance)	200
dB (lower distance)	0
dC (upper distance)	750
dP (front radiation)	1000
dF (floor radiation)	1000
dL (side radiation)	1000

KEY

1	FLOOR	4	FLOOR GUARD
2	FRONT FLAMMABLE MATERIAL	5	RADIATED SURFACE TO BE PROTECTED
3	AREA SUBJECT TO RADIATION	6	REAR/SIDE/UPPER FLAMMABLE SURFACE

If the floor is made of combustible material, use a protection made of non-combustible material (steel, glass...) that also protects the front from any falling combusted material during cleaning operations.



Always fit a floor guard if the floor is made of flammable material.

Install the stove also detached from any non-combustible walls/surfaces, observing a minimum clearance of 200 mm (back) and 200 mm (side) to allow effective aeration of the appliance and a good distribution of heat in the room.

2-INSTALLATION

In any case, ensure adequate distance to facilitate access during cleaning and extraordinary maintenance. If this is not possible, it must still be possible to distance the product from adjacent walls/elements.

This operation must be performed by a technician qualified to disconnect the combustion product expulsion ducts and their subsequent restoration.

For generators connected to the hydraulic system, a connection must be provided between the system itself and the product so that, during extraordinary maintenance, carried out by a qualified technician, it is possible to move the generator by at least 50 cm from adjacent walls without emptying the system (e.g. by using a double shut-off gate or suitable flexible connection).

Air inlet

It is mandatory to provide an adequate external air inlet that supplies the combustion air required for the product to work properly. The flow of air between the outside and the installation room can take place with a free air inlet or by channelling the air directly to the outside³.

The free air inlet must:

- be made at floor level
- always be protected with an outer grille and in such a way that it cannot be obstructed by any object
- have a minimum total free area of 80 cm² (net of the grille)

The presence of other suction devices (e.g.: vmc, electric fan for stale air extraction, kitchen hood, other stoves, etc.), in the same room could cause negative pressure in the room. In this case, with the exception of sealed installations, one must verify that, with all the equipment on, no more than 4 Pa of negative pressure is created inside the installation room with respect to the outside. If necessary, increase the air inlet section.

It is possible to duct the air required for combustion to the outside by connecting the external air inlet directly with the combustion air inlet which is usually found on the back of the appliance.

The duct must comply with the following dimensions (each 90° bend is equivalent to one linear metre):

³ in the event the combustion air is ducted on unsealed products, still verify that no more than 4 Pa of negative pressure is created inside the installation room with respect to the outside, otherwise provide for an additional air intake in the room.

2-INSTALLATION

Below 15kW:

Air duct diameter	Maximum length (smooth duct)	Maximum length (corrugated duct)
50mm	2m	1m
60mm	3m	2m
80mm	7m	4m
100mm	12m	9m

Above 15kW:

Air duct diameter	Maximum length (smooth duct)	Maximum length (corrugated duct)
50mm	-	-
60mm	1m	-
80mm	3m	1m
100mm	7m	4m

2-INSTALLATION

Preparing the smoke expulsion system

The combustion product expulsion system is a particularly important element for the proper operation of the appliance and must be correctly sized according to EN 13384-1.

Its creation/adaptation/verification must always be carried out by a legally qualified operator and must comply with the regulations in force in the country where the appliance is installed.

The Manufacturer declines all liability for malfunctions caused by a badly sized and non-compliant smoke expulsion system.

Smoke duct (smoke fitting)

The smoke duct is the pipe that connects the appliance to the flue.

This smoke fitting must comply in particular with the following requirements:

- comply with product standard EN 1856-2;
- its cross-section must be of constant diameter and no less than that of the appliance outlet, from the firebox outlet up to the connection in the flue;
- the horizontal section must be as short as possible and extend no more than 4 metres;
- the horizontal sections must have a minimum upward slope of 3%;
- changes of direction must have an angle no greater than 90° and be easy to inspect
- the number of changes of direction, including that for entry into the flue, and exclusion of the T in the event of a side or rear outlet, must not exceed 3;
- it must be insulated if it passes outside the installation room
- it must not in any case cross rooms in which it is forbidden to install combustion appliances.
- the use of flexible metal and fibre cement or aluminium hoses is forbidden;

In any case, smoke ducts must be sealed against combustion products and any condensation. For this reason, it is recommended to use pipes with silicone gaskets or similar sealing devices that withstand the operating temperatures of the appliance (e.g. T200 P1) and that by removing the gaskets, are still T400 N1 G certified.

Flue (chimney or piped duct)

When creating the flue, in particular comply with the following requirements:

- comply with the applicable product standard (EN 1856, EN 1857 EN 1457, EN 1806, EN 13063...);
- be made with suitable materials to ensure resistance to normal mechanical, chemical, thermal stresses and have adequate thermal insulation in order to limit the formation of condensate;
- have a predominantly vertical configuration and be free of choke points along its entire length;
- be correctly spaced by air gaps and isolated from combustible materials;
- the flue inside the house must still be insulated and can be inserted in an air shaft provided it complies with the regulations for piping;
- the smoke duct must be connected to the flue by means of a Tee fitting with an inspectable collection chamber for the collection of soot and any condensate.
- where the sizing provides for wet operation, a suitable condensate collection and siphon discharge system must be set up.



We recommend checking the data plates of the flue for the safety distances that must be observed in the presence of combustible materials and, if necessary, the type of insulating material to be used.

It is forbidden to connect the stove to a collective or shared flue (*) with other combustion appliances or with hood outlets.

It is forbidden to use the direct drain on the wall or towards indoor spaces and any other form of drain not provided for by the regulation in force in the country of installation.

2-INSTALLATION

Chimneypot

The chimneypot, meaning the end part of the flue, must meet the following characteristics:

- the smoke outlet section must be at least double the internal section of the chimney;
- prevent the penetration of rain or snow;
- ensure the outlet of smoke even in the event of wind (windproof chimneypot);
- the height of outflow must be beyond the reflux area (*) (refer to national regulations to identify the reflux area);
- always be built at a distance from antennas or dishes, and never be used as a support.

(*) unless there are specific national derogations (clearly specified in the corresponding instruction manual in English) which under appropriate conditions allow it; in this case, strictly follow the product/installation requirements of the relative regulations/technical specifications/legislation in force in that country.

2-INSTALLATION

EXAMPLES OF INSTALLATION⁴ (DIAMETERS AND LENGTHS TO BE SIZED)

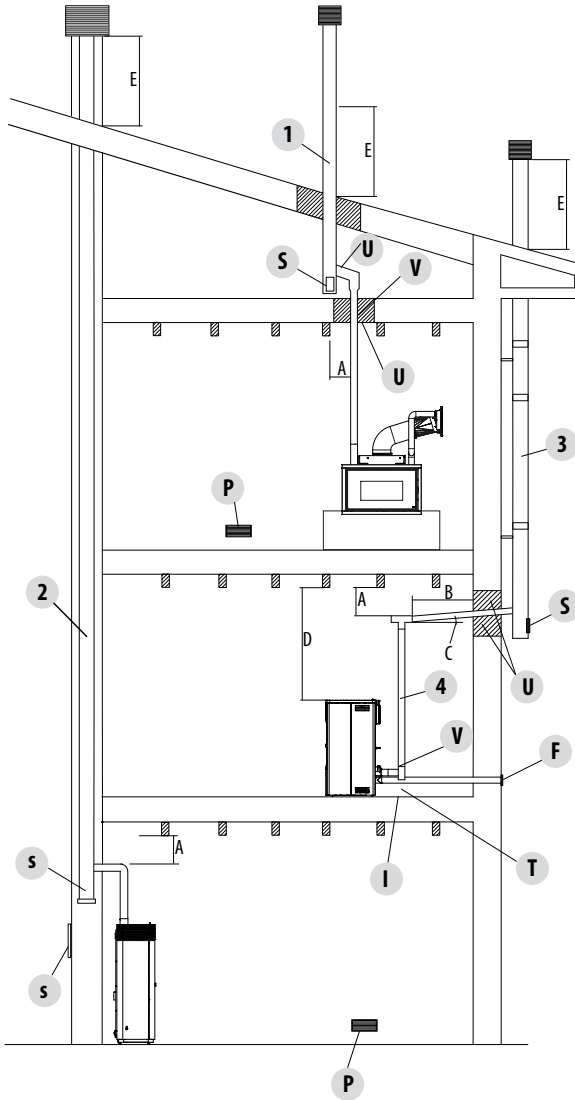

1. Flue installation with hole for the passage of the pipe increased by:

- minimum 100mm around the pipe if next to non-flammable parts such as cement, brick, etc.; or
- minimum 300mm around the pipe (or as required by plate data) if next to flammable parts such as wood etc.

In both cases, install suitable insulation between the flue and the ceiling.

Always check and comply with the plate data of the flue, specifically the minimum safety distances from combustible materials.

The previous rules also apply for holes made in walls.

2. Old flue, pipe with the inclusion of an external access door for chimney cleaning.

3. External flue made of insulated stainless-steel pipes, i.e. with double walls: all securely mounted on the wall. With windproof chimney pot.

4. Ducting system using Tee fittings that allow easy access for cleaning without having to remove the pipes

- U=INSULATION
 V=POSSIBLE DIAMETER INCREASE
 I=INSPECTION CAP
 S=INSPECTION ACCESS PANEL
 P=AIR INLET
 T=TEE FITTING WITH INSPECTION CAP
 A=DISTANCE FROM FLAMMABLE MATERIAL (SMOKE DUCT PLATE)
 B=MAXIMUM 4 M
 C=MINIMUM 3° SLOPE
 D=DISTANCE FROM FLAMMABLE MATERIAL (APPLIANCE PLATE)
 E=REFLUX AREA
 F=AIR DUCTING

⁴The figure shows typical, but not exhaustive, examples of all possible installations (which must always be approved by a qualified technician)

3-DRAWINGS AND TECHNICAL SPECIFICATIONS

DRAWINGS AND CHARACTERISTICS

SUITE HYDROMATIC 18/24/24 ACS M2 STOVE DIMENSIONS

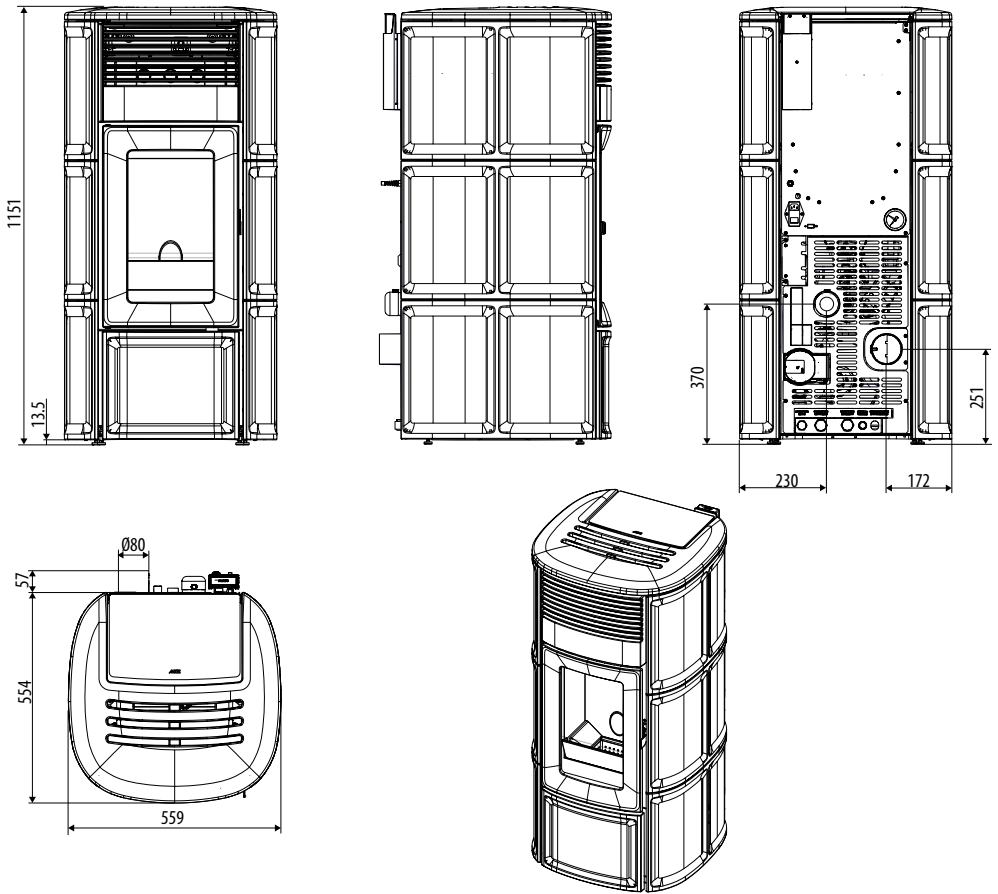

3-DRAWINGS AND TECHNICAL SPECIFICATIONS

CLUB HYDROMATIC 18/24/24 ACS M2 STOVE DIMENSIONS

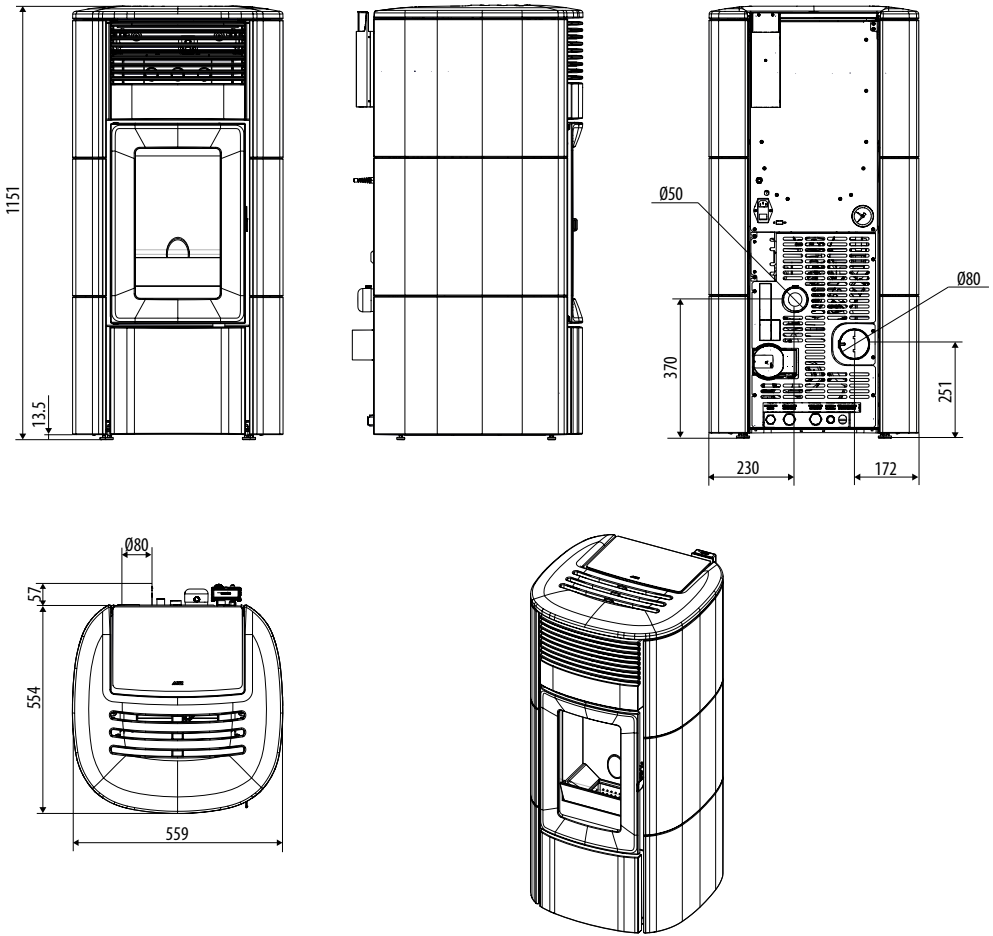

3-DRAWINGS AND TECHNICAL SPECIFICATIONS

MUSA HYDROMATIC 18/24 M2 STOVE DIMENSIONS

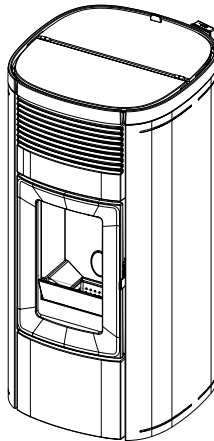
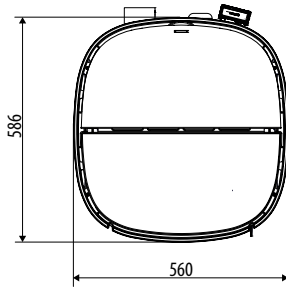
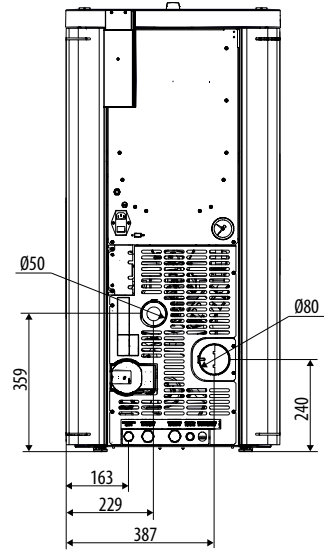
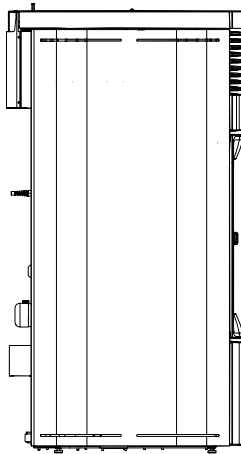
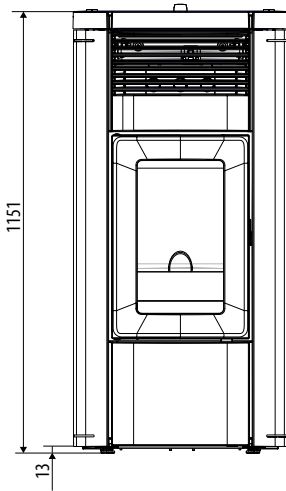

3-DRAWINGS AND TECHNICAL SPECIFICATIONS

TECHNICAL CHARACTERISTICS	SUITE-CLUB-MUSA HYDROMATIC 18 M2
Energy Efficiency Class	A++
Nominal output power	17,7 kW (15222 kcal/h)
Nominal output power (H ₂ O)	12,7 kW (10922 kcal/h)
Minimum output power	4,4 kW (3784 kcal/h)
Minimum output power (H ₂ O)	2,3 kW (1978 kcal/h)
Efficiency at Max	94,8%
Efficiency at Min	95,9%
Temperature of exhaust smoke at Max	107 °C ⁽¹⁾
Temperature of exhaust smoke at Min	55°C ⁽¹⁾
Particles/OGC/Nox (13%O ₂)	10 mg/Nm ³ - 2 mg/Nm ³ - 99 mg/Nm ³
CO at 13% O ₂ at Min and at Max	0,017 – 0,009%
CO ₂ at Min and at Max	5,9% - 13,0%
Smoke mass at Min and at Max	5,4-10,6 g/sec
Max operating temperature	2,0 bar - 200 kPa
Recommended draught at Max power***	0,10 mbar - 10 Pa***
Recommended draught at Min power	0,02 mbar - 2 Pa
Hopper capacity	40 litres
Type of pellet fuel	Pellet diameter 6 mm and size 3 ÷ 40 mm
Pellet hourly consumption	Min ~ 1,0 kg/h* - Max ~ 3,9 kg/h*
Autonomy	Max. ~ 26 h* - Min. ~ 7 h*
Heatable volume m ³	322/55 – 506/35 – 885/20 **
Combustion air inlet	Ø 50 mm
Smoke outlet	Ø 80 mm
Air inlet	80 cm ²
Rated electrical power (EN 60335-1)	126 W (Max 370 W)
Supply voltage and frequency	230 Volt / 50 Hz
Net weight	197 kg
Weight with packaging	214 kg
Distance from flammable material (rear/side/bottom)	200 / 200 / 0 mm
Distance from flammable material (ceiling/front)	750 / 1000 mm

* Data that may vary depending on the type of pellets used

** Volume that can be heated, according to the power requirement per m³ (respectively 55-35-20 Kcal/h per m³)

***Value recommended by the manufacturer (non-binding) for optimal product operation

Tested according to EN 14785 in accordance with European regulation for Construction Products (UE 305/2011)

⁽¹⁾ **To properly size the chimney (in accordance with EN 13884-1), use the smoke temperature exactly detected at the outlet of the appliance, or the above stated temperature increased by 20% (e.g. stated temperature 100°C: product outlet temperature 120°C)**

3-DRAWINGS AND TECHNICAL SPECIFICATIONS

TECHNICAL CHARACTERISTICS	SUITE-CLUB Hydromatic 24/24 ACS M2 MUSA Hydromatic 24 M2
Energy Efficiency Class	A++
Nominal output power	24,2 kW (20812 kcal/h)
Nominal output power (H ₂ O)	18,2 kW (15652 kcal/h)
Minimum output power	4,4 kW (3784 kcal/h)
Minimum output power (H ₂ O)	2,3 kW (1978 kcal/h)
Efficiency at Max	92,9%
Efficiency at Min	95,9%
Temperature of exhaust smoke at Max	143 °C ⁽¹⁾
Temperature of exhaust smoke at Min	55°C ⁽¹⁾
Particles/OGC/Nox (13%O ₂)	12 mg/Nm ³ - 1 mg/Nm ³ - 92 mg/Nm ³
CO at 13% O ₂ at Min and at Max	0,017 – 0,014%
CO ₂ at Min and at Max	5,9% - 13,6%
Smoke mass at Min and at Max	5,4-14,2 g/sec
Max operating temperature	2,0 bar - 200 kPa
Recommended draught at Max power***	0,10 mbar - 10 Pa***
Recommended draught at Min power	0,02 mbar - 2 Pa
Hopper capacity	40 litres
Type of pellet fuel	Pellet diameter 6 mm and size 3÷40 mm
Pellet hourly consumption	Min ~ 1,0 kg/h* - Max ~ 5,4 kg/h*
Autonomy	Max. ~ 26 h* - Min. ~ 5 h*
Heatable volume m ³	440/55 – 691/35 – 1210/20 **
Combustion air inlet	Ø 50 mm
Smoke outlet	Ø 80 mm
Air inlet	80 cm ²
Rated electrical power (EN 60335-1)	126 W (Max 370 W)
Supply voltage and frequency	230 Volt / 50 Hz
Net weight	197 kg
Weight with packaging	214 kg
Distance from flammable material (rear/side/bottom)	200 / 200 / 0 mm
Distance from flammable material (ceiling/front)	750 / 1000 mm

* Data that may vary depending on the type of pellets used

** Volume that can be heated, according to the power requirement per m³ (respectively 55-35-20 Kcal/h per m³)

***Value recommended by the manufacturer (non-binding) for optimal product operation

Tested according to EN 14785 in accordance with European regulation for Construction Products (UE 305/2011)

⁽¹⁾ To properly size the chimney (in accordance with EN 13884-1), use the smoke temperature exactly detected at the outlet of the appliance, or the above stated temperature increased by 20% (e.g. stated temperature 100°C: product outlet temperature 120°C)

**INFORMATION REQUIREMENTS FOR SOLID FUEL LOCAL SPACE HEATERS
ACCORDING TO COMMISSION REGULATIONS (EU) 2015/1185 - (EU) 2015/1186 (PRODUCT FICHE)**

Manufacturer: **MCZ GROUP SpA**
 Trademark: **MCZ**
 Model Identifier: **SUITE HYDROMATIC 18 M2 / CLUB HYDROMATIC 18 M2**

Indirect heating functionality: **YES**
 Direct heat output (space heat output): **5,0 kW**
 Indirect heat output (water heat output): **12,7 kW**
 CPR harmonised standard: **EN 14785:2006**
 Product description: **Mechanically fed roomheater fitted with a boiler burning wood pellets**

Notified Body: **IMQ (N.B. 0051)**
Via Quintiliano 43, 20138 Milano, IT

Fuel	Preferred fuel:	Other suitable fuel(s):	η_s [%]	EEl [%]
Log wood, moisture content ≤ 25 %	NO	NO		
Compressed wood with moisture content < 12 %	YES	NO	91,6	134
Other woody biomass	NO	NO		

Observe the specific precautions for installation, assembly and maintenance indicated in the manual accompanying the product, and the national and local rules in force

Energy Efficiency Class **A++** (A+++ / G scale)

Characteristics when operating with the preferred fuel:

Space heating emissions (mg/Nm ³ at 13% O ₂)	CO	NO _x	OGC	PM
at Nominal heat output	106	99	2	10
at Minimum heat output	209	100	6	12

Heat output			
Item	Symbol	Value	Unit
Nominal heat output	P_{nom}	17,7	kW
Minimum heat output (indicative)	P_{min}	4,4	kW
Useful efficiency (NCV as received)			
Useful efficiency at nominal heat output	$\eta_{Th,nom}$	94,8	%
Useful efficiency at minimum heat output (indicative)	$\eta_{Th,min}$	95,9	%
Auxiliary electricity consumption			
At nominal heat output	$e_{l,max}$	0,126	kW
At minimum heat output	$e_{l,min}$	0,065	kW
In standby mode	$e_{l,cb}$	0,005	kW

Type of heat output/room temperature control (select one)	
single stage heat output, no room temperature control	NO
two or more manual stages, no room temperature control	NO
with mechanic thermostat room temperature control	NO
with electronic room temperature control	NO
with electronic room temperature control plus day timer	NO
with electronic room temperature control plus week timer	YES
Other control options (multiple selections possible)	
room temperature control, with presence detection	NO
room temperature control, with open window detection	NO
with distance control option	YES

**INFORMATION REQUIREMENTS FOR SOLID FUEL LOCAL SPACE HEATERS
ACCORDING TO COMMISSION REGULATIONS (EU) 2015/1185 - (EU) 2015/1186 (PRODUCT FICHE)**

Manufacturer: MCZ GROUP SpA
Trademark: MCZ
Model Identifier: SUITE HYDROMATIC 24 M2 / CLUB HYDROMATIC 24 ACS M2 / CLUB HYDROMATIC 24 M2 / SUITE HYDROMATIC 24 ACS M2

Indirect heating functionality: YES
Direct heat output (space heat output): 6,0 kW
Indirect heat output (water heat output): 18,2 kW
CPR harmonised standard: EN 14785:2006
Product description: Mechanically fed roomheater fitted with a boiler burning wood pellets

Notified Body: IMQ (N.B. 0051)
 Via Quintiliano 43, 20138 Milano, IT

Fuel	Preferred fuel:	Other suitable fuel(s):	η_s [%]	EEI [%]
Log wood, moisture content ≤ 25 %	NO	NO		
Compressed wood with moisture content < 12 %	YES	NO	90,0	132
Other woody biomass	NO	NO		

Observe the specific precautions for installation, assembly and maintenance indicated in the manual accompanying the product, and the national and local rules in force

Energy Efficiency Class **A++** (A++ / G scale)

Characteristics when operating with the preferred fuel:

Space heating emissions (mg/Nm ³ at 13% O ₂)	CO	NO _x	OGC	PM
at Nominal heat output	169	92	1	12
at Minimum heat output	209	100	6	12

Heat output			
Item	Symbol	Value	Unit
Nominal heat output	P_{nom}	24,2	kW
Minimum heat output (indicative)	P_{min}	4,4	kW
Useful efficiency (NCV as received)			
Useful efficiency at nominal heat output	$\eta_{th,nom}$	92,9	%
Useful efficiency at minimum heat output (indicative)	$\eta_{th,min}$	95,9	%
Auxiliary electricity consumption			
At nominal heat output	$e_{l,max}$	0,126	kW
At minimum heat output	$e_{l,min}$	0,065	kW
In standby mode	$e_{l,sp}$	0,005	kW

Type of heat output/room temperature control (select one)	
single stage heat output, no room temperature control	NO
two or more manual stages, no room temperature control	NO
with mechanic thermostat room temperature control	NO
with electronic room temperature control	NO
with electronic room temperature control plus day timer	NO
with electronic room temperature control plus week timer	YES
Other control options (multiple selections possible)	
room temperature control, with presence detection	NO
room temperature control, with open window detection	NO
with distance control option	YES

**INFORMATION REQUIREMENTS FOR SOLID FUEL LOCAL SPACE HEATERS
ACCORDING TO COMMISSION REGULATIONS (EU) 2015/1185 - (EU) 2015/1186 (PRODUCT FICHE)**

Manufacturer: **MCZ GROUP SpA**
 Trademark: **MCZ**
 Model Identifier: **MUSA HYDROMATIC 18 M2**

Indirect heating functionality: **YES**
 Direct heat output (space heat output): **5,0 kW**
 Indirect heat output (water heat output): **12,7 kW**
 CPR harmonised standard: **EN 14785:2006**
 Product description: **Mechanically fed roomheater fitted with a boiler burning wood pellets**

Notified Body: **IMQ (N.B. 0051)**
Via Quintiliano 43, 20138 Milano, IT

Fuel	Preferred fuel:	Other suitable fuel(s):	η_s [%]	EEl [%]
Log wood, moisture content ≤ 25 %	NO	NO		
Compressed wood with moisture content < 12 %	YES	NO	91,6	134
Other woody biomass	NO	NO		

Observe the specific precautions for installation, assembly and maintenance indicated in the manual accompanying the product, and the national and local rules in force

Energy Efficiency Class **A++** (A+++ / G scale)

Characteristics when operating with the preferred fuel:

Space heating emissions (mg/Nm ³ at 13% O ₂)	CO	NO _x	OGC	PM
at Nominal heat output	106	99	2	10
at Minimum heat output	209	100	6	12

Heat output			
Item	Symbol	Value	Unit
Nominal heat output	P_{nom}	17,7	kW
Minimum heat output (indicative)	P_{min}	4,4	kW
Useful efficiency (NCV as received)			
Useful efficiency at nominal heat output	$\eta_{Th,nom}$	94,8	%
Useful efficiency at minimum heat output (indicative)	$\eta_{Th,min}$	95,9	%
Auxiliary electricity consumption			
At nominal heat output	$e_{l,max}$	0,126	kW
At minimum heat output	$e_{l,min}$	0,065	kW
In standby mode	$e_{l,sb}$	0,005	kW

Type of heat output/room temperature control (select one)	
single stage heat output, no room temperature control	NO
two or more manual stages, no room temperature control	NO
with mechanic thermostat room temperature control	NO
with electronic room temperature control	NO
with electronic room temperature control plus day timer	NO
with electronic room temperature control plus week timer	YES
Other control options (multiple selections possible)	
room temperature control, with presence detection	NO
room temperature control, with open window detection	NO
with distance control option	YES

**INFORMATION REQUIREMENTS FOR SOLID FUEL LOCAL SPACE HEATERS
ACCORDING TO COMMISSION REGULATIONS (EU) 2015/1185 - (EU) 2015/1186 (PRODUCT FICHE)**

Manufacturer: **MCZ GROUP SpA**
 Trademark: **MCZ**
 Model Identifier: **MUSA HYDROMATIC 24 M2**

Indirect heating functionality: **YES**
 Direct heat output (space heat output): **6,0 kW**
 Indirect heat output (water heat output): **18,2 kW**
 CPR harmonised standard: **EN 14785:2006**
 Product description: **Mechanically fed roomheater fitted with a boiler burning wood pellets**

Notified Body: **IMQ (N.B. 0051)**
Via Quintiliano 43, 20138 Milano, IT

Fuel	Preferred fuel:	Other suitable fuel(s):	η_s [%]	EEl [%]
Log wood, moisture content ≤ 25 %	NO	NO		
Compressed wood with moisture content < 12 %	YES	NO	90,0	132
Other woody biomass	NO	NO		

Observe the specific precautions for installation, assembly and maintenance indicated in the manual accompanying the product, and the national and local rules in force

Energy Efficiency Class **A++** (A+++ / G scale)

Characteristics when operating with the preferred fuel:

Space heating emissions (mg/Nm ³ at 13% O ₂)	CO	NO _x	OGC	PM
at Nominal heat output	169	92	1	12
at Minimum heat output	209	100	6	12

Heat output			
Item	Symbol	Value	Unit
Nominal heat output	P_{nom}	24,2	kW
Minimum heat output (indicative)	P_{min}	4,4	kW
Useful efficiency (NCV as received)			
Useful efficiency at nominal heat output	$\eta_{Th, nom}$	92,9	%
Useful efficiency at minimum heat output (indicative)	$\eta_{Th, min}$	95,9	%
Auxiliary electricity consumption			
At nominal heat output	$e_{l, max}$	0,126	kW
At minimum heat output	$e_{l, min}$	0,065	kW
In standby mode	$e_{l, sb}$	0,005	kW







Type of heat output/room temperature control (select one)	
single stage heat output, no room temperature control	NO
two or more manual stages, no room temperature control	NO
with mechanic thermostat room temperature control	NO
with electronic room temperature control	NO
with electronic room temperature control plus day timer	NO
with electronic room temperature control plus week timer	YES
Other control options (multiple selections possible)	
room temperature control, with presence detection	NO
room temperature control, with open window detection	NO
with distance control option	YES

4-UNPACKING

INSTRUCTIONS FOR PACKAGING DISPOSAL

The material that the appliance's packaging is made of must be managed correctly, in order to make collection, reuse, recovery and recycling easier, where possible.

The table below illustrates the possible components that the packaging is made of, and the relative instructions for correct disposal.

DESCRIPTION	CODE MATERIAL	SYMBOL	DIRECTIONS FOR COLLECTION
WOOD BED	WOOD FOR 50		SORTED waste collection
WOOD CAGE			WOOD
WOOD PALLET			Check with the competent body on how to dispose of this packaging at the recycling depot
CARDBOARD BOX	CORRUGATED CARDBOARD PAP 20		SORTED waste collection
CARDBOARD CORNER			PAPER
CARDBOARD SHEET			Check the instructions of the competent body
APPLIANCE BAG	POLYETHYLENE LD-PE 04		SORTED waste collection
BAG OF ACCESSORIES			PLASTIC
BUBBLE WRAP			Check the instructions of the competent body
PROTECTIVE SHEET			
LABELS			
POLYSTYRENE	POLYSTYRENE PS 06		SORTED waste collection
FOAM PEANUTS			PLASTIC
			Check the instructions of the competent body
STRAP	POLYPROPYLENE PP 05 POLYESTER PET 01	 	SORTED waste collection
TAPE			PLASTIC
			Check the instructions of the competent body.
SCREWS	IRON FE 40		SORTED waste collection
STAPLES FOR STRAP			METAL
FASTENING BRACKET			Check with the competent body on how to dispose of this packaging at the recycling depot

4-UNPACKING



Handle the product with suitable means paying attention to the applicable safety regulations in force. Do not turn the packaging over and handle the majolica parts with care.

The stoves are delivered in a single package with the ceramic panels packaged together with the structure and placed on top of it. Open the package, remove the cardboard, polystyrene and any straps and position the stove in the preset place making sure that it complies with the requirements.

The stove body or unit must always be kept in a vertical position when handled, and handled using trolleys only. Pay particular attention to the door and its glass, protecting them from mechanical knocks that would compromise their integrity.

If possible, unwrap the stove near the chosen area of installation.

The packaging materials are neither toxic nor harmful.

SUITE/CLUB CERAMIC PANELS PACKAGING

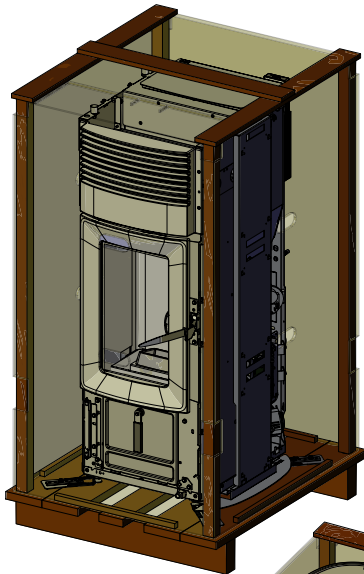
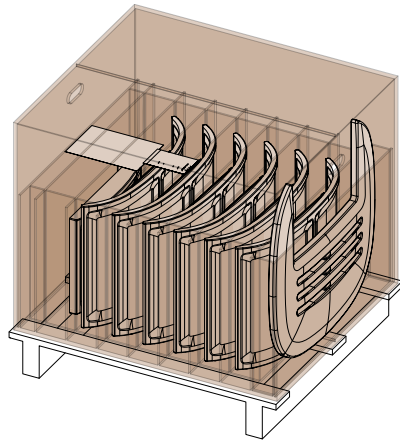

SUITE/CLUB STRUCTURE PACKAGING

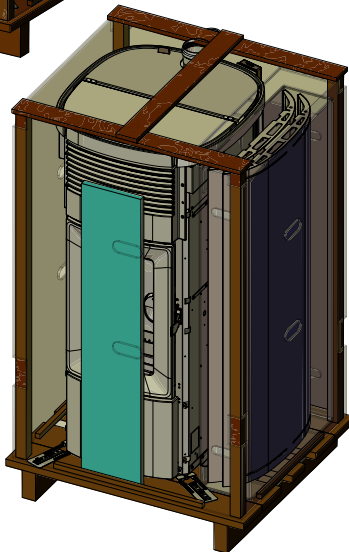

MUSA STRUCTURE PACKAGING

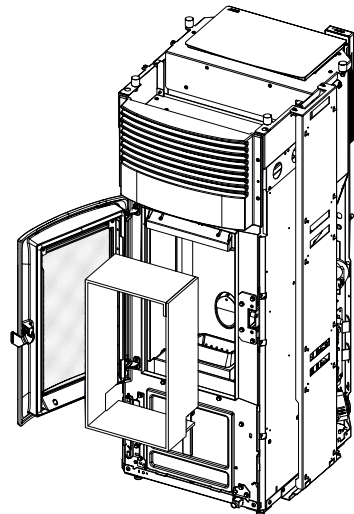

FIREBOX CARDBOARD REMOVAL

4-UNPACKING

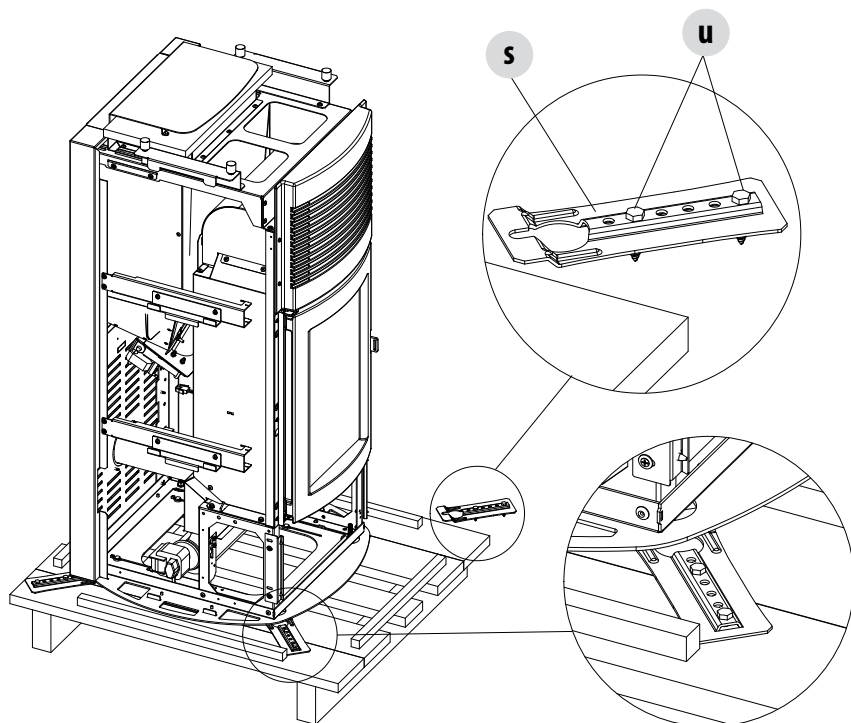

REMOVING THE FASTENING BRACKETS
(SUITE/CLUB STOVES)

To remove the SUITE/CLUB/MUSA stove from the pallet, you must remove the two screws "u" and plate "s" from the stove's foot. There are four brackets "s".

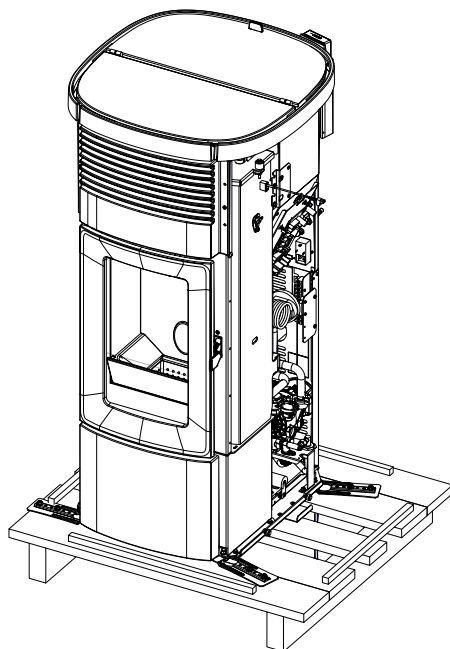

REMOVING THE FASTENING BRACKETS
(MUSA STOVES)

4-UNPACKING

Position the stove and connect it to the flue. Use the 4 adjustable feet (**J**) to get the stove correctly levelled so that the smoke outlet is lined up with the connecting pipe.

If the stove needs to be connected to an outlet pipe which goes through the rear wall (to connect to the flue), take the utmost care to make sure that the joint is not forced.



If the stove smoke outlet is forced or used improperly to lift it or position it, the operation of the stove can be damaged irreparably.

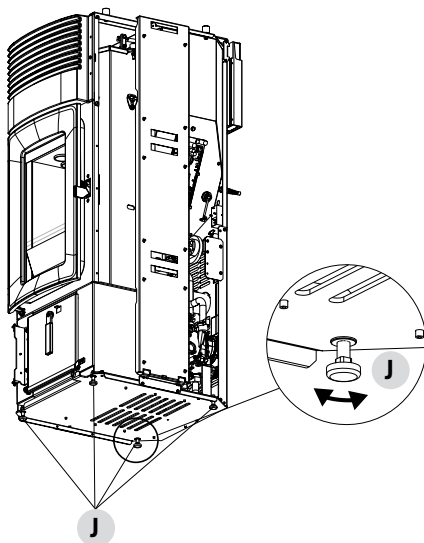

1. TURN THE FEET CLOCKWISE TO LOWER THE STOVE
2. TURN THE FEET ANTICLOCKWISE TO RAISE THE STOVE

5-SUIT/CLUB STOVE ASSEMBLY



Live electrical parts: only power the product once it has been fully assembled.

On delivery, the Suite and Club stoves have no ceramic cladding, as shown in the image below.

Take the box with the ceramics (figure below) and prepare them for installation. The ceramics are already completely assembled (ceramics and mounting brackets) and must be mounted as per the attached diagram, "Side panels assembly" page.

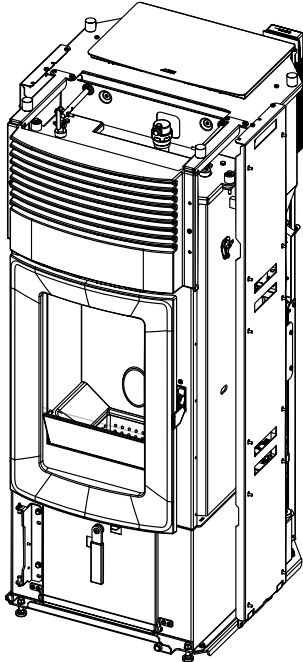

STOVE STRUCTURE

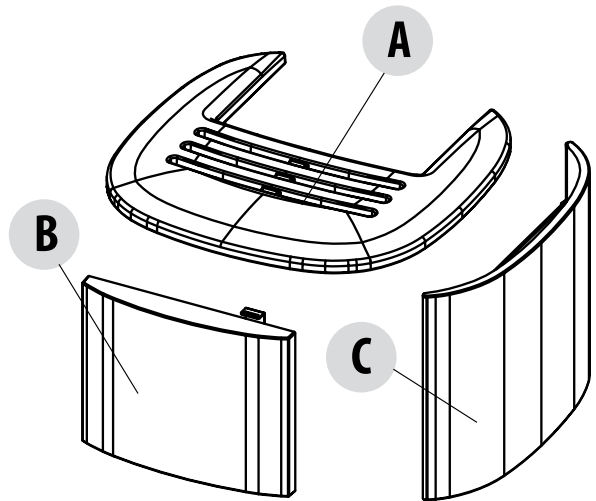

CERAMIC CLADDING

The ceramics are delicate, therefore handle with care.

POS.	DESCRIPTION	No.	POS.	DESCRIPTION	No.
A	CERAMIC TOP	1	n	M4X12 FLAT WASHER	24
B	LOWER CERAMIC PANEL	1	k	M4X16 SCREW	2
C*	LATERAL CERAMIC PANEL	6			
m	M4X10 SCREW	24			
THE FIGURE SHOWS SUITE STOVE CERAMICS (THE DECORATION CHANGES FOR CERAMICA CLUB)					

C* = BASED ON THE LAYOUT, THE CERAMICS WILL BE CALLED D1/D2/D3 AND S1/S2/S3

5-SUIT/CLUB STOVE ASSEMBLY

INSTALLING THE SIDE PANELS

There are codes on the internal part of the ceramics to help correctly position them. As shown in the following image, on the right side they are called D1/D2/D3 and on the left side S1/S2/S3, to be placed from the bottom upwards.

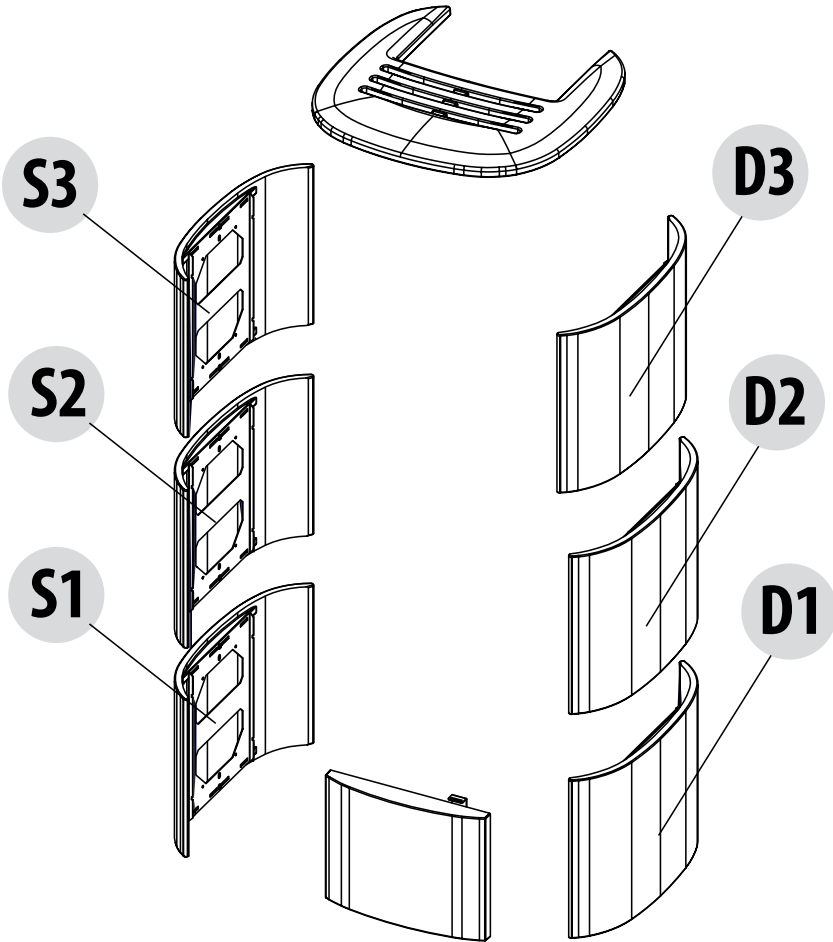

5-SUIT/CLUB STOVE ASSEMBLY

REMOVING THE CERAMIC PANELS FASTENING FRAME

Remove the two screws "x" and the two notched washers "z" from the top part.



Attention! The two screws "x" and the two notched washers "z" must be used again to secure the frame with the ceramic panels.

Therefore, it is recommended to fit them back onto the stove's structure until they are used again.

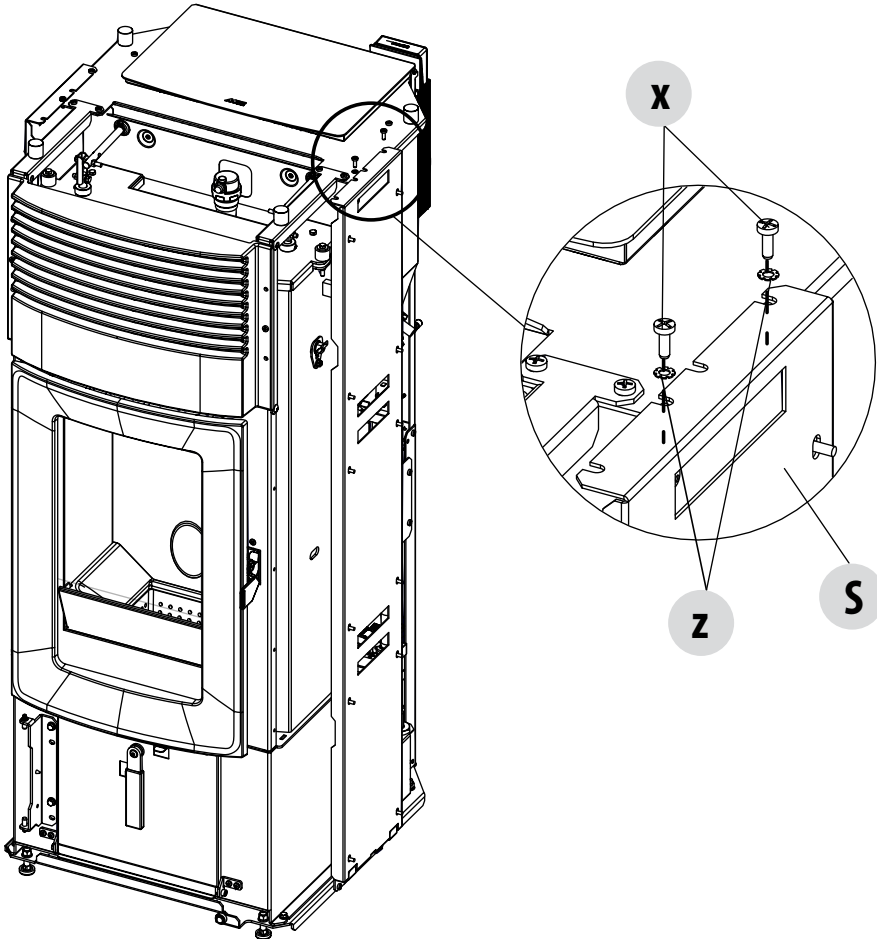

5-SUIT/CLUB STOVE ASSEMBLY

Make the holes "V" of the frame "S" come out from the hooks "L" on the structure of the stove.

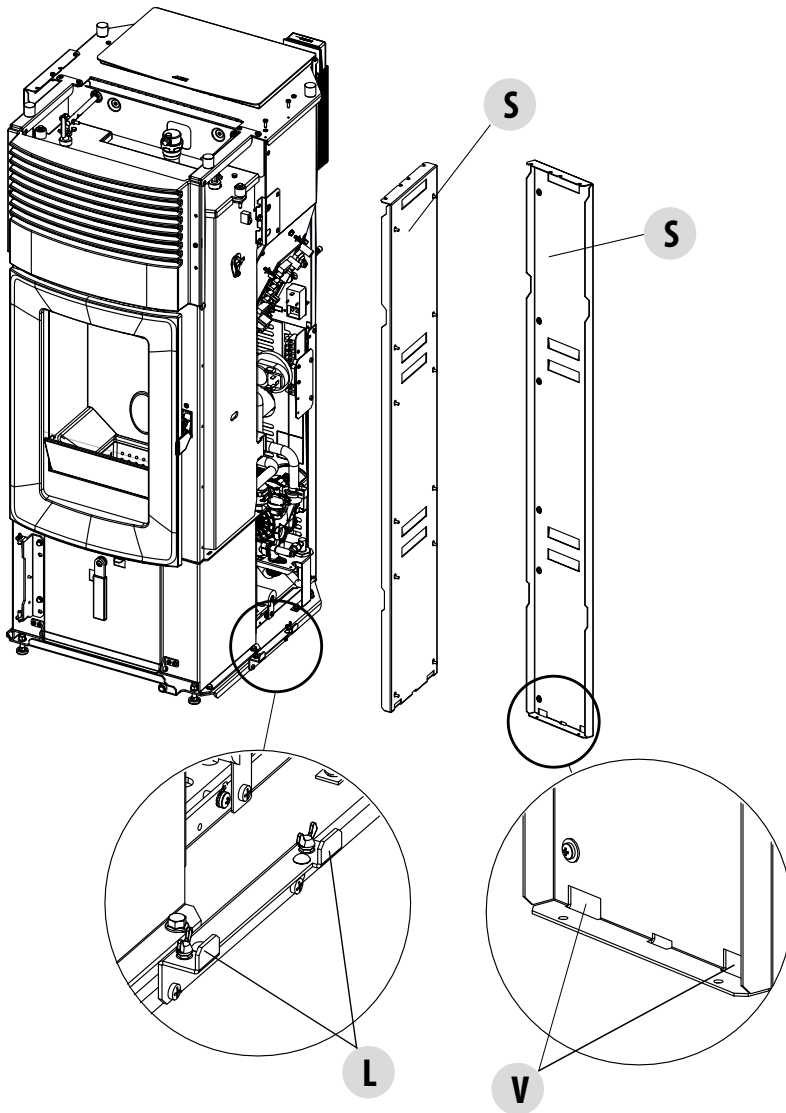

5-SUIT/CLUB STOVE ASSEMBLY

Take the template "U" from the structure's packaging, which must be used to position the ceramic panels correctly. The part of the template marked "FRONT RIGHT" must be positioned as indicated in the picture, towards the front part of the stove. Use the two screws "k" supplied with the ceramic panels and secure the template "u" to the frame "S".

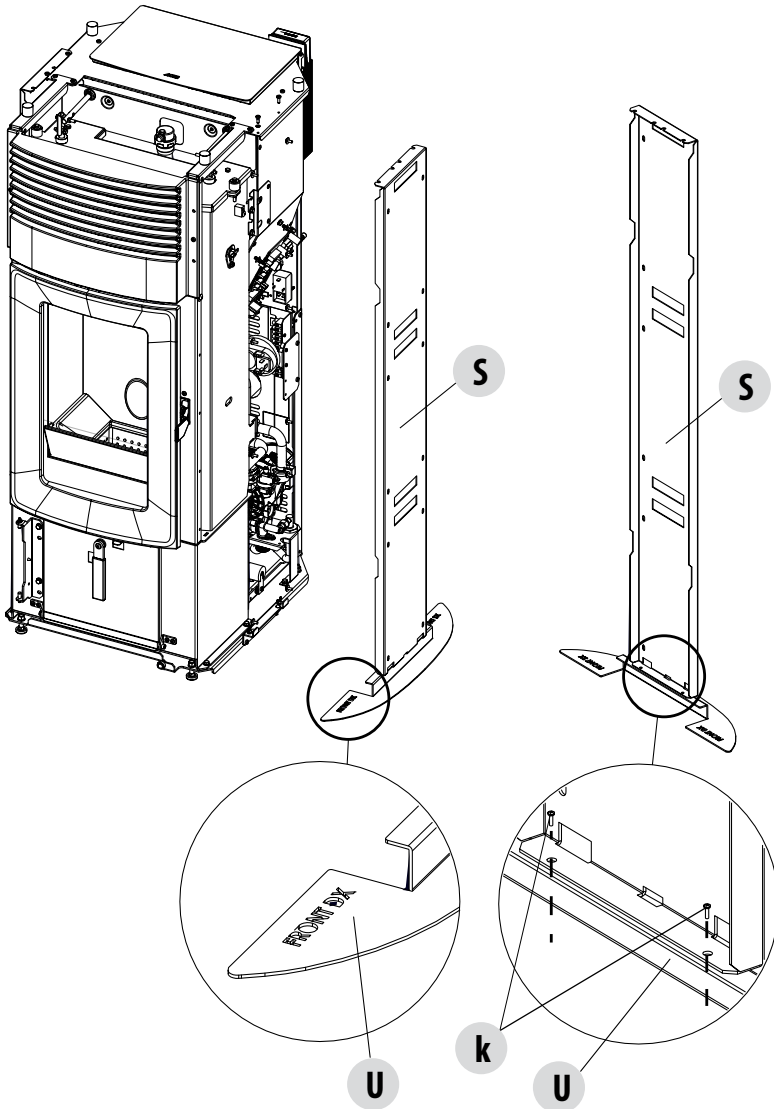

5-SUIT/CLUB STOVE ASSEMBLY

From the ceramic panels packaging, take the three ceramic panels marked "D1", "D2", "D3". Place a sheet or cloth on the floor "T" to avoid scratching or damaging the ceramic panels during assembly.
Place the three ceramic panels on the sheet "T" on the floor, as indicated in the picture.

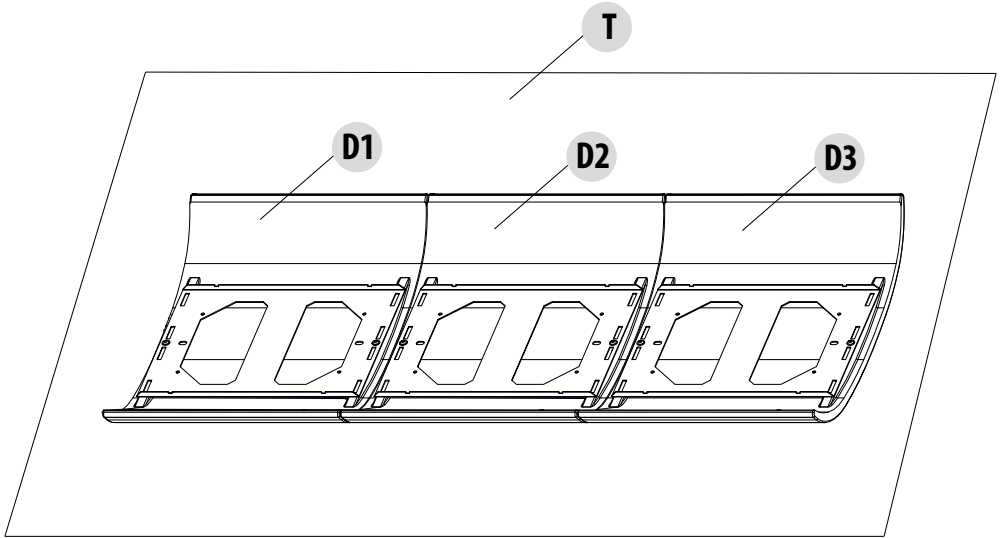

Take the frame "S" with the template "U" you have just prepared and place it on the ceramic panels "D1", "D2", "D3".
The template "U" must adhere to the ceramic panel marked "D1"

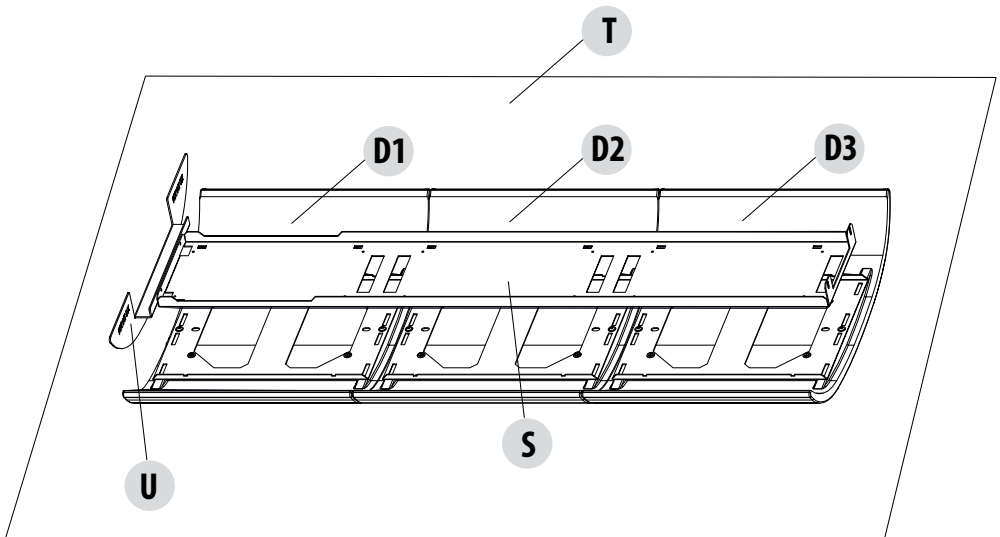

5-SUIT/CLUB STOVE ASSEMBLY

Now, take the 12 screws "m" and 12 washers "n" from the ceramic panel package. Secure the frame "S" to the ceramic panels using the screws "m" and washers "n".

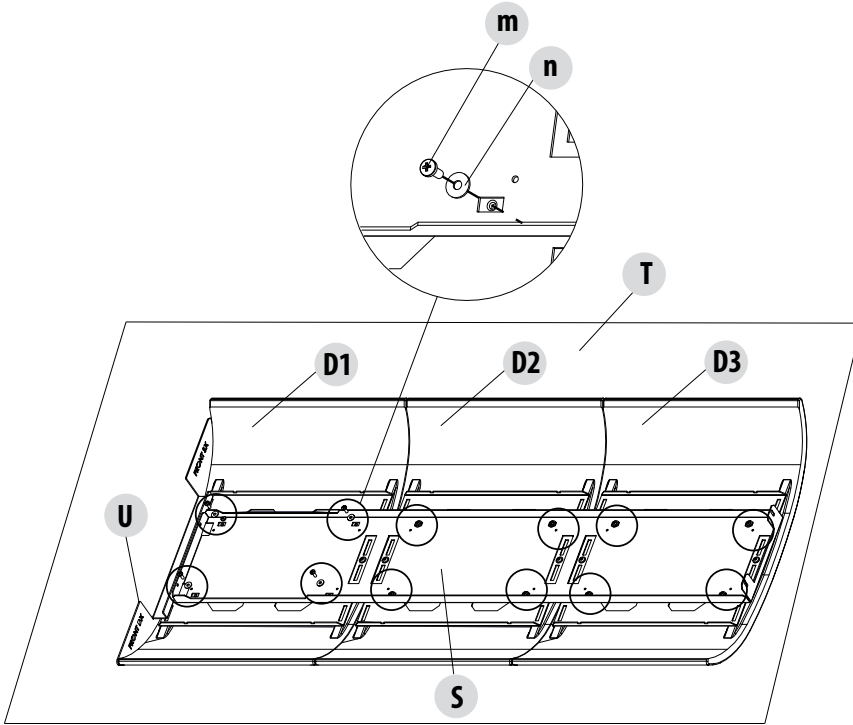

After securing the frame/ceramic panels, remove the two screws "k" and remove the template "U".

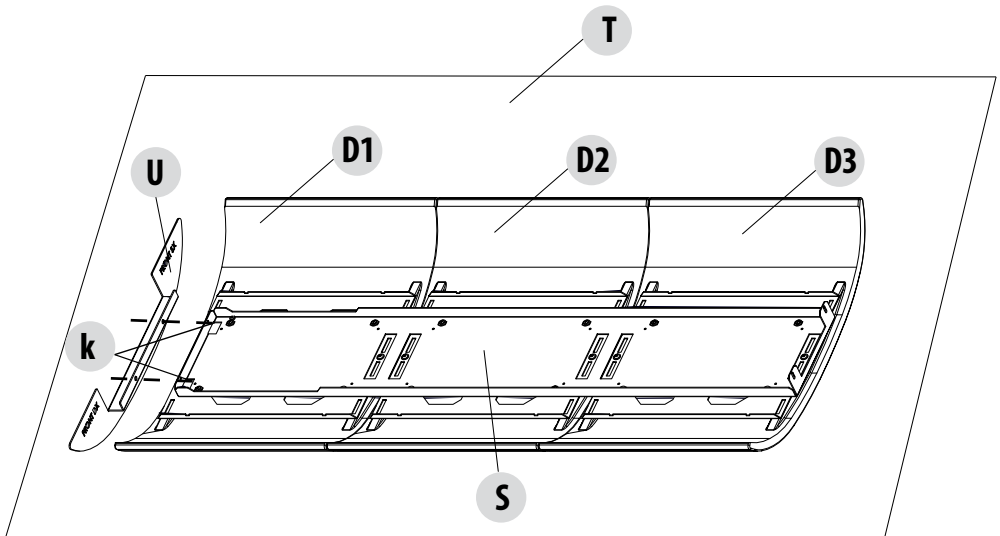

5-SUIT/CLUB STOVE ASSEMBLY

Lift the three ceramic panels with the frame and secure it to the stove's structure.

At the bottom, insert the holes "V" on the frame of the ceramic panels into the hooks "L" fitted on the structure of the stove.

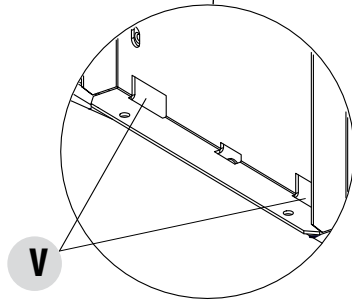
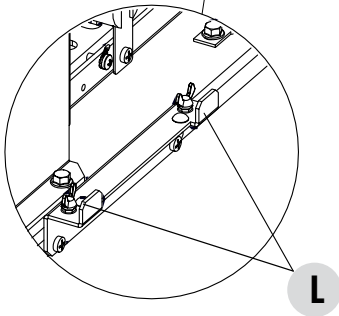
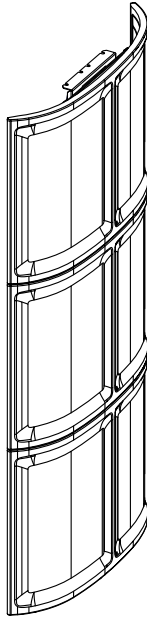
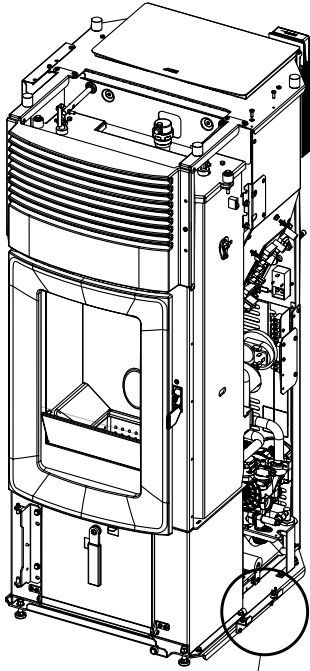

5-SUIT/CLUB STOVE ASSEMBLY

On the top, secure the frame to the structure with the two screws "x" and notched washers "z" that were previously removed with the frame "S".



Attention! The frame with the ceramic panels has slotted holes "f" to adjust the ceramic panels with the front parts of the stove.

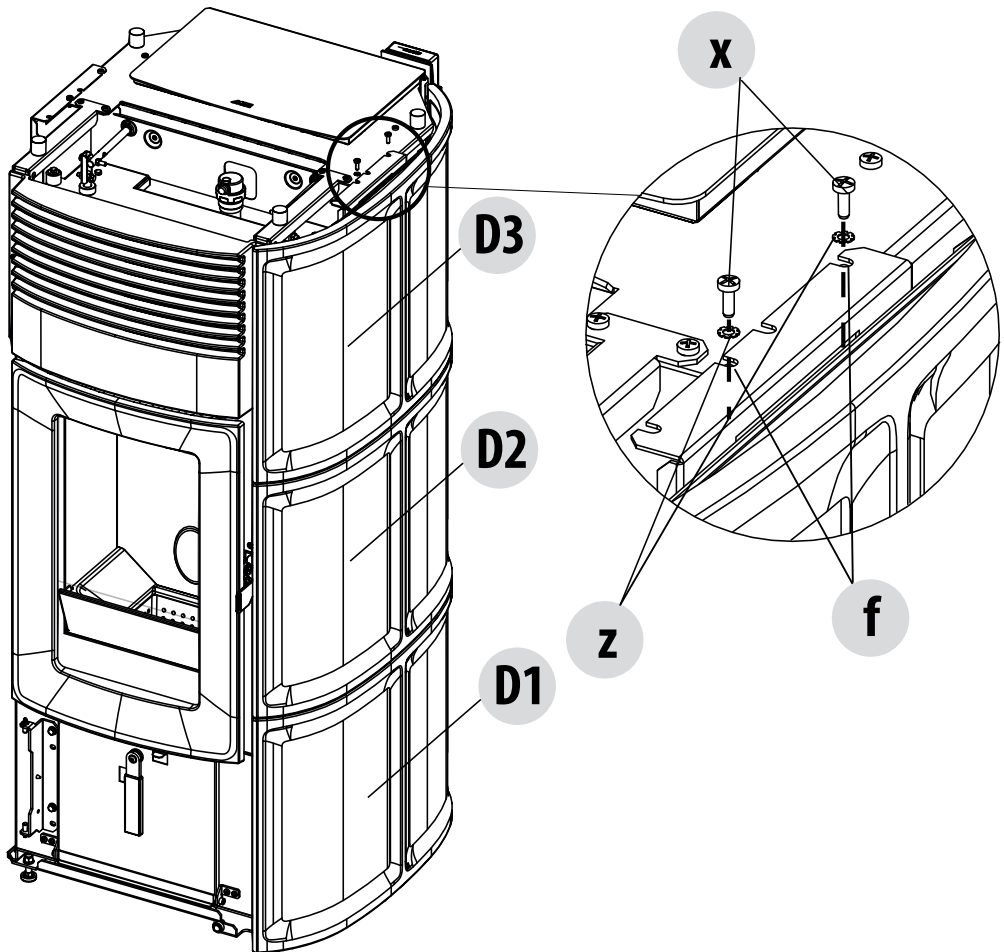

5-SUIT/CLUB STOVE ASSEMBLY

Repeat the same operation also for the ceramic panels marked "S1", "S2", "S3".

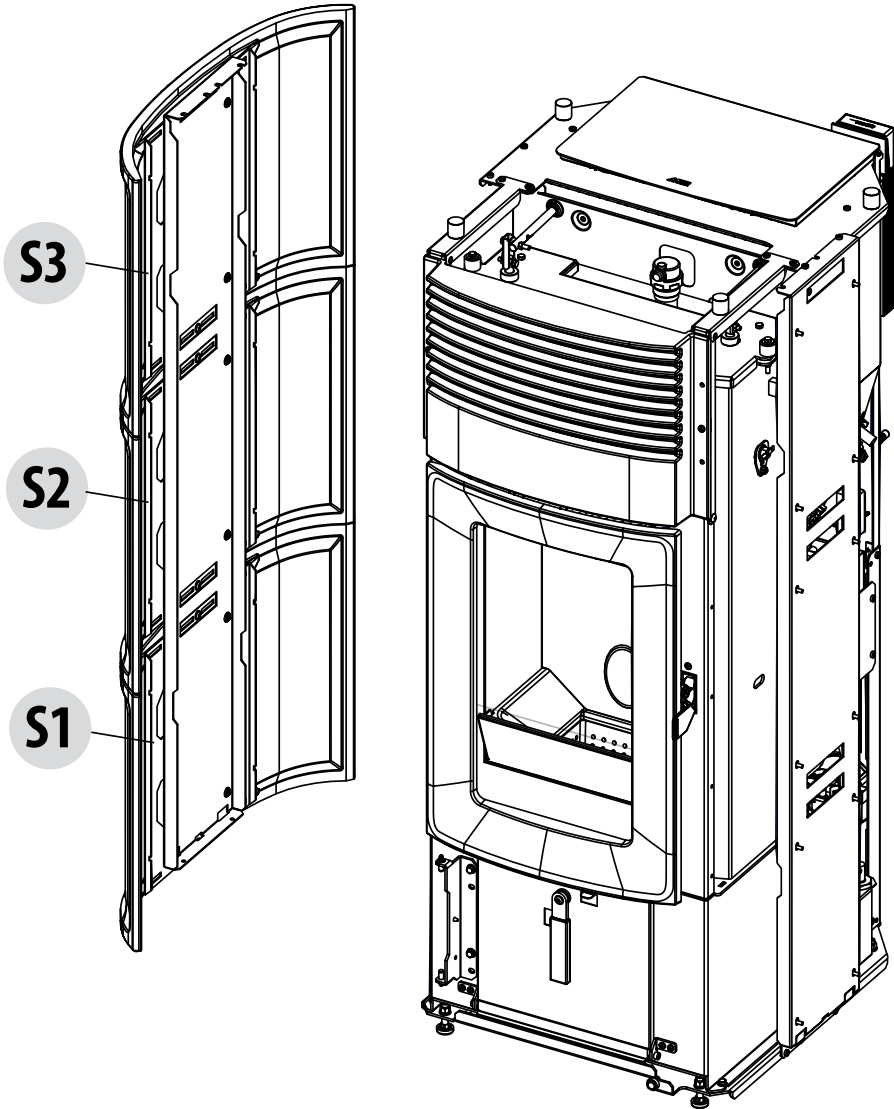

5-SUIT/CLUB STOVE ASSEMBLY

INSTALLING THE FRONT LOWER CERAMIC PANEL

Remove the two screws "j" from the structure of the stove and remove the bracket "0".

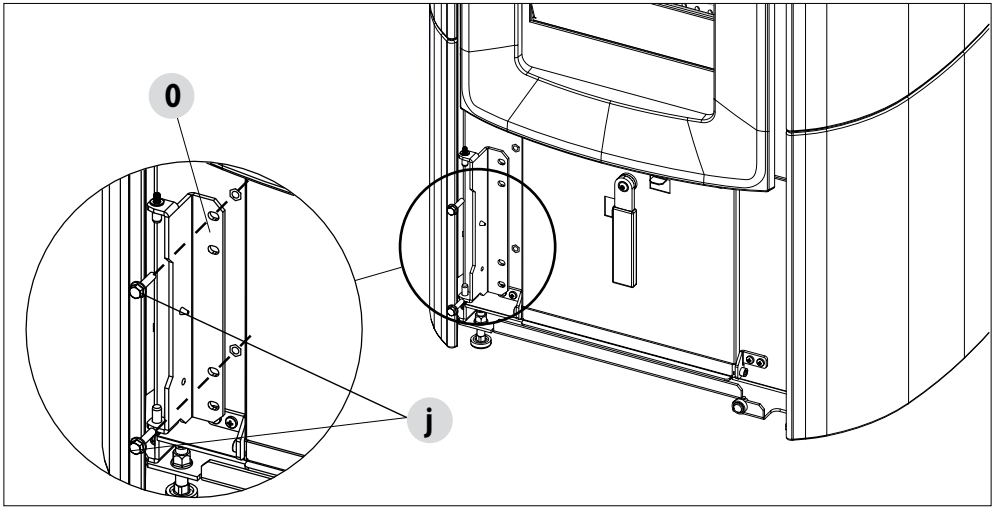

Take the ceramic panel "B" from the package of the ceramic panels.
Remove the M4x16 screw "g" from the lower part of the bracket "0".

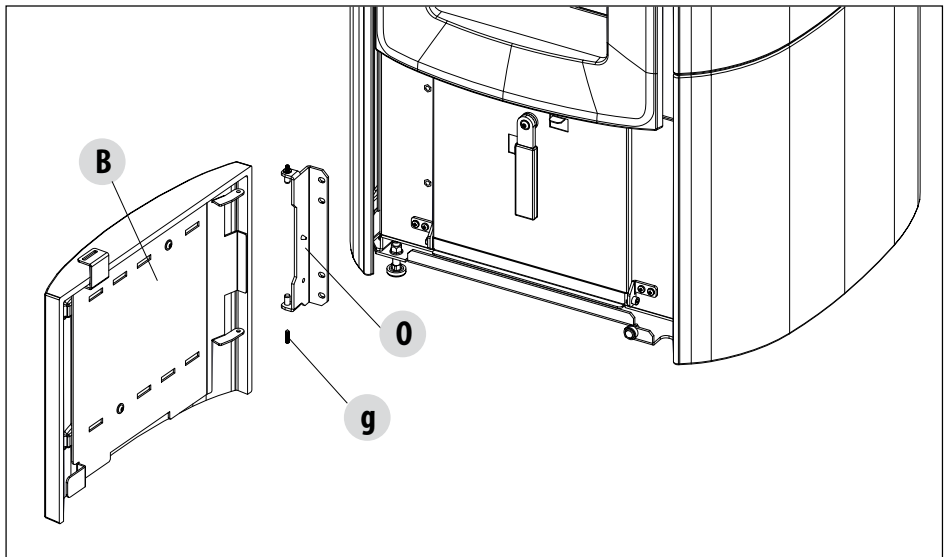

5-SUIT/CLUB STOVE ASSEMBLY

Insert the bracket "O" into the frame of the ceramic panel "B" and secure it in the lower part with the screw "g" you have just removed.

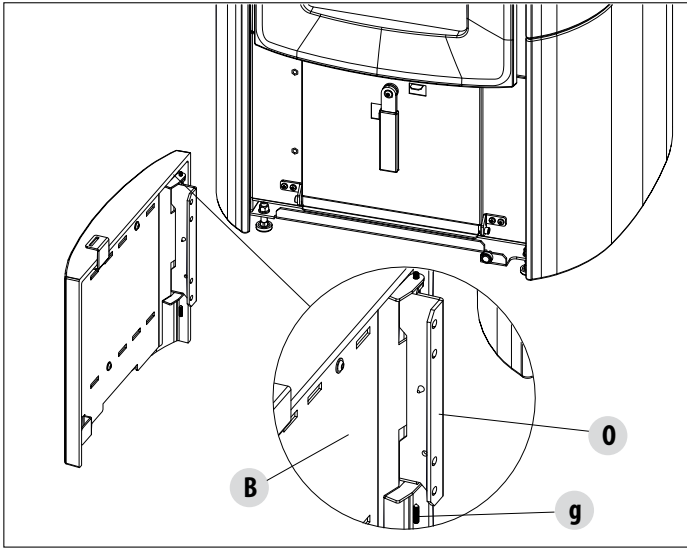

Now secure the ceramic panel "B" to the structure of the stove using the two screws "j".

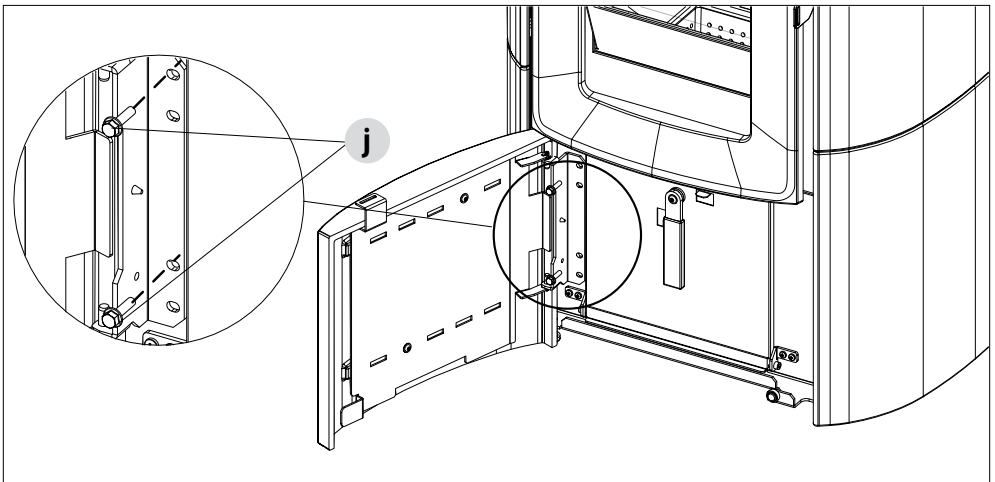

5-SUIT/CLUB STOVE ASSEMBLY

ADJUSTING THE LOWER PANEL

It is possible to adjust the magnet "r" from the screw "v". Then, try to bring the ceramic panel "B" flush with the door of the firebox by adjusting the magnet "r".

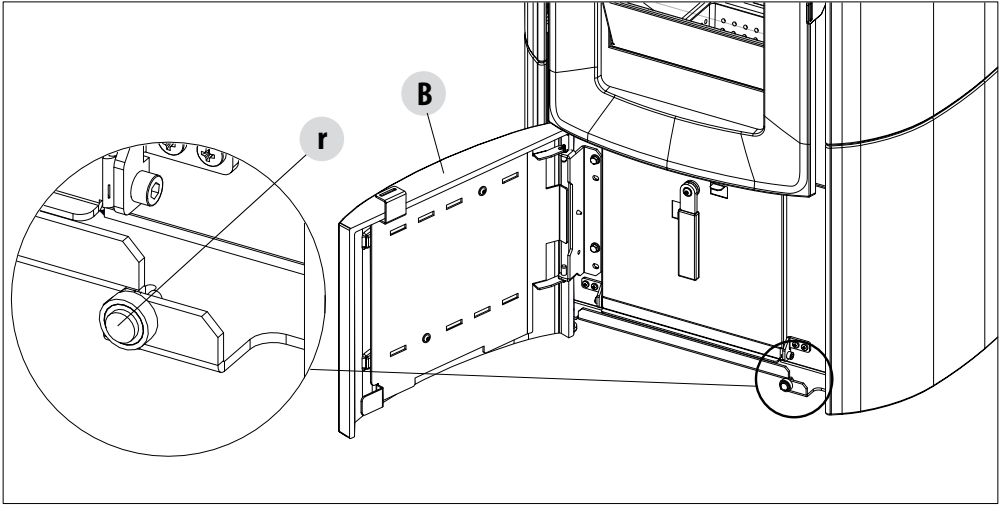

5-SUIT/CLUB STOVE ASSEMBLY

ASSEMBLING THE TOP

At this point, the side panels are assembled, as well as the lower panel. Before proceeding with placing the top "A", perform a final check of the position of the side panels.

Make sure they are in line with the front panels and the door. If necessary, adjust them from the slots on the frame of the side ceramic panels.

It is now possible to place the top "A" onto the rubber spacers "P". Also in this case, the rubber spacers "A" must be adjusted so that the top "A" is raised from the side ceramic panels by 3 mm.

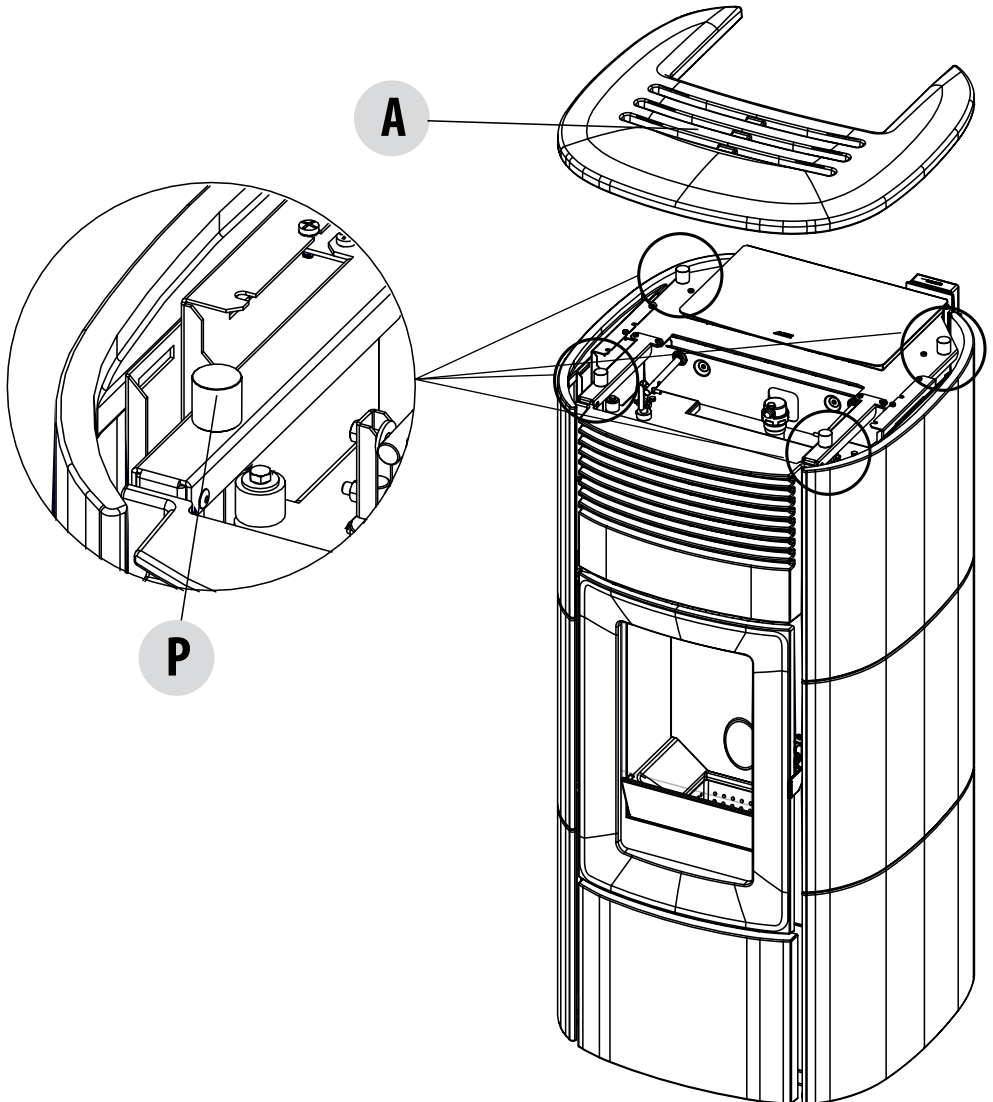

5-SUIT/CLUB STOVE ASSEMBLY

REMOVING THE UPPER PANEL

Panel "F" is already fixed to the stove structure, it may be removed in the event of maintenance, servicing or cleaning. After removing any top, remove screws "k", two on the right and two on the left, and remove the top front panel "F".

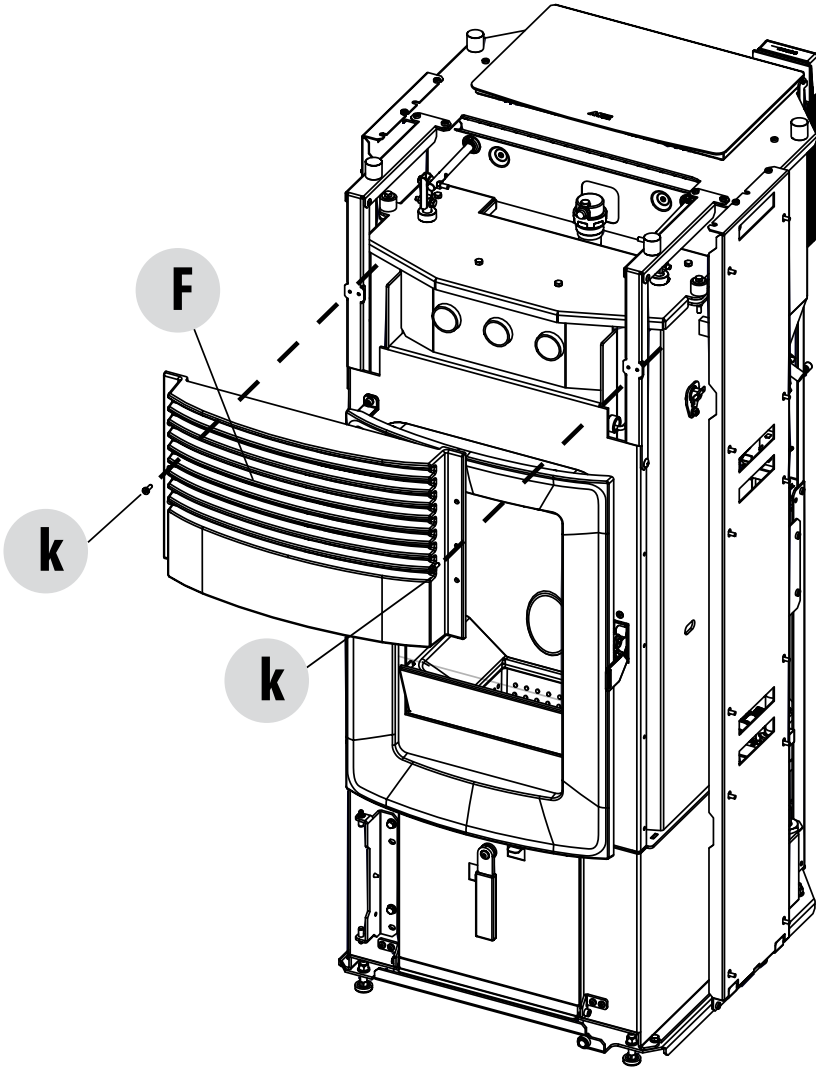

6-MUSA STOVE ASSEMBLY



Live electrical parts: only power the product once it has been fully assembled.

On delivery, the MUSA stove has no metal cladding and has the top fitted, as shown below.

Take the box with the metal sides and prepare them for installation. The sides are fitted with screws for fixing to the structure.

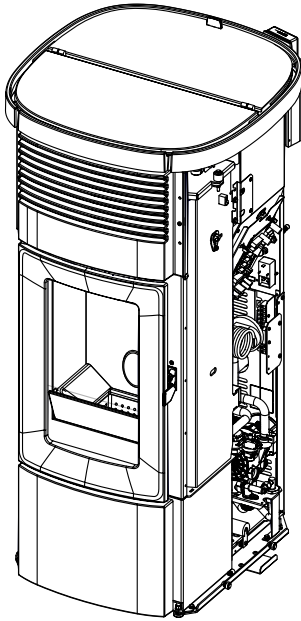

STOVE STRUCTURE

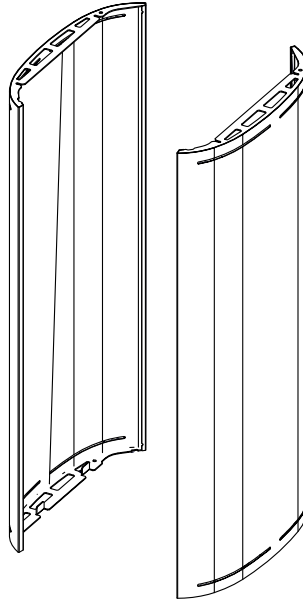

METAL CLADDING

Caution! Carefully handle the metal sides as the paint might be damaged.

POS.	DESCRIPTION	N.
E	METAL SIDE	2
n	M4 NOTCHED WASHER	4
m	M4X12 SCREW	4

6-MUSA STOVE ASSEMBLY

REMOVING THE TOP

Removal of the top is not required for assembling the metal sides. It can be removed for servicing or any needs and if required, to assemble the sides more easily.

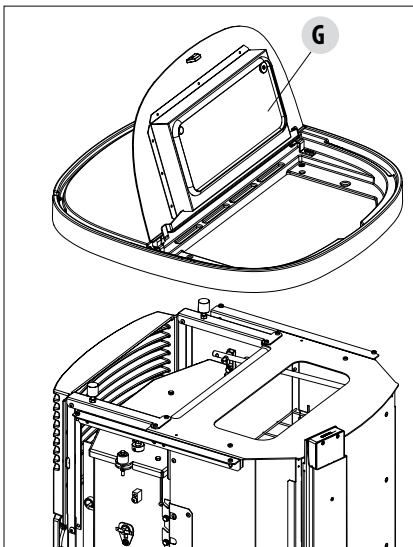
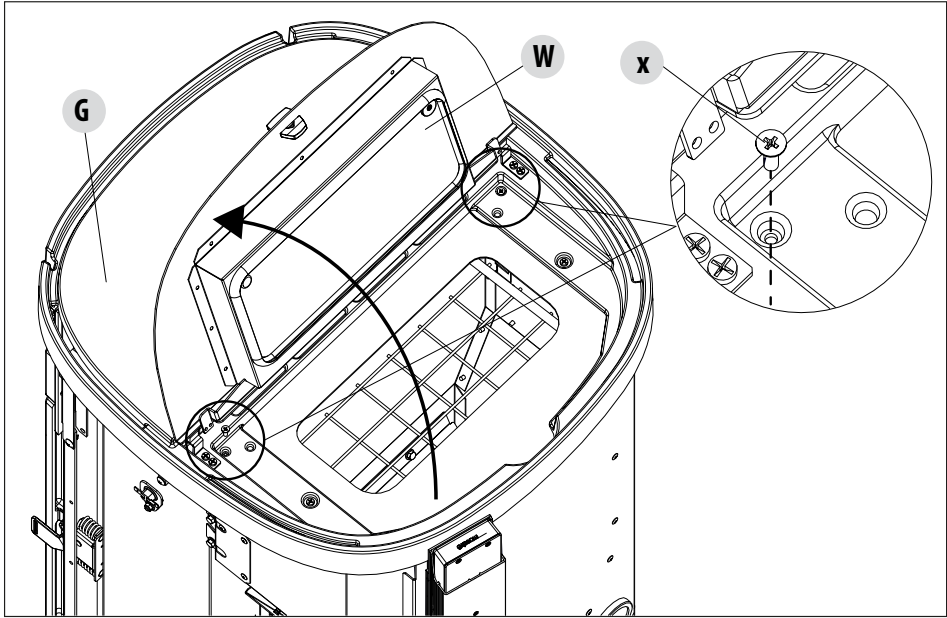

Lift the pellet cover "W", remove the two screws "x" and remove the complete top "G".

6-MUSA STOVE ASSEMBLY

ASSEMBLING THE METAL SIDES

Mount the metal sides by proceeding as follows:

- Pre-fasten on the stove structure the washer "n" and the screw "m" in the part below the top.

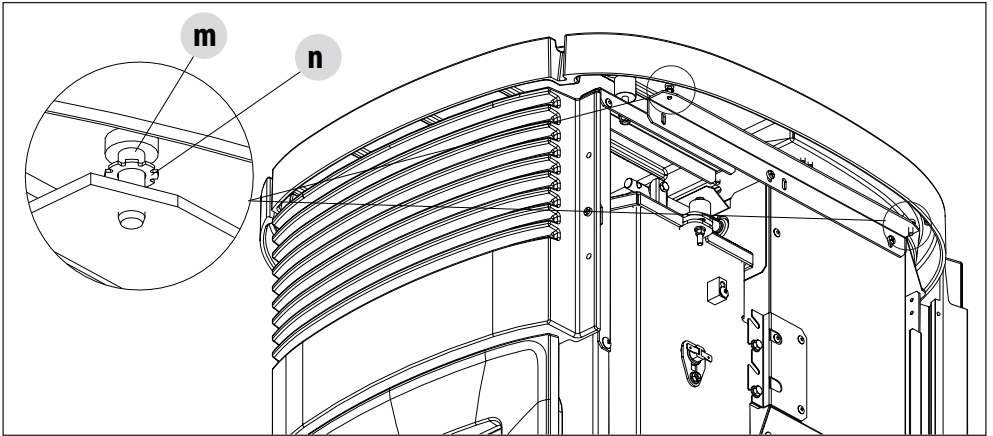

- After inserting the panel in the lower part of the stove (see next page) move panel "E" close to the structure so that the slots "p" house the screw "m" that has been attached to the structure before.

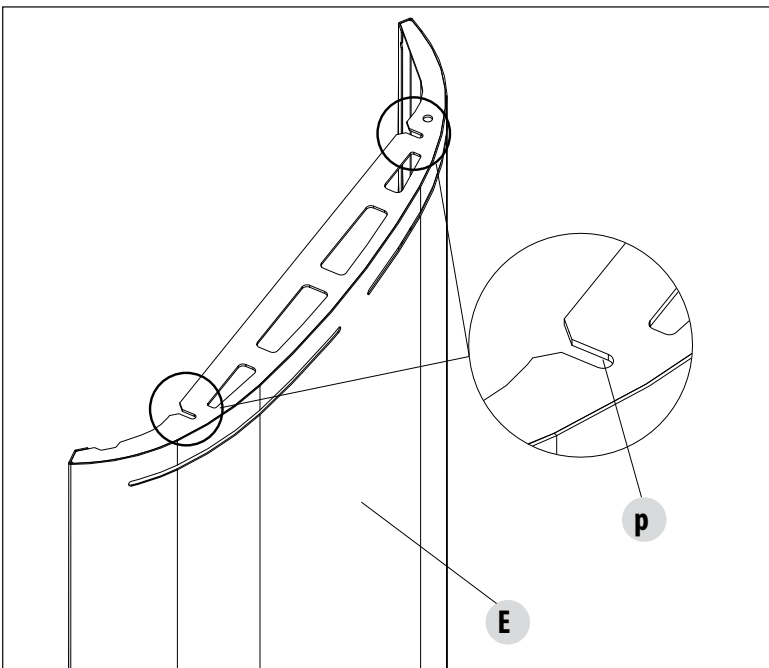

6-MUSA STOVE ASSEMBLY

At the bottom, insert the hook "z" fitted on the structure of the stove into the hole "v" on the side metal panel.

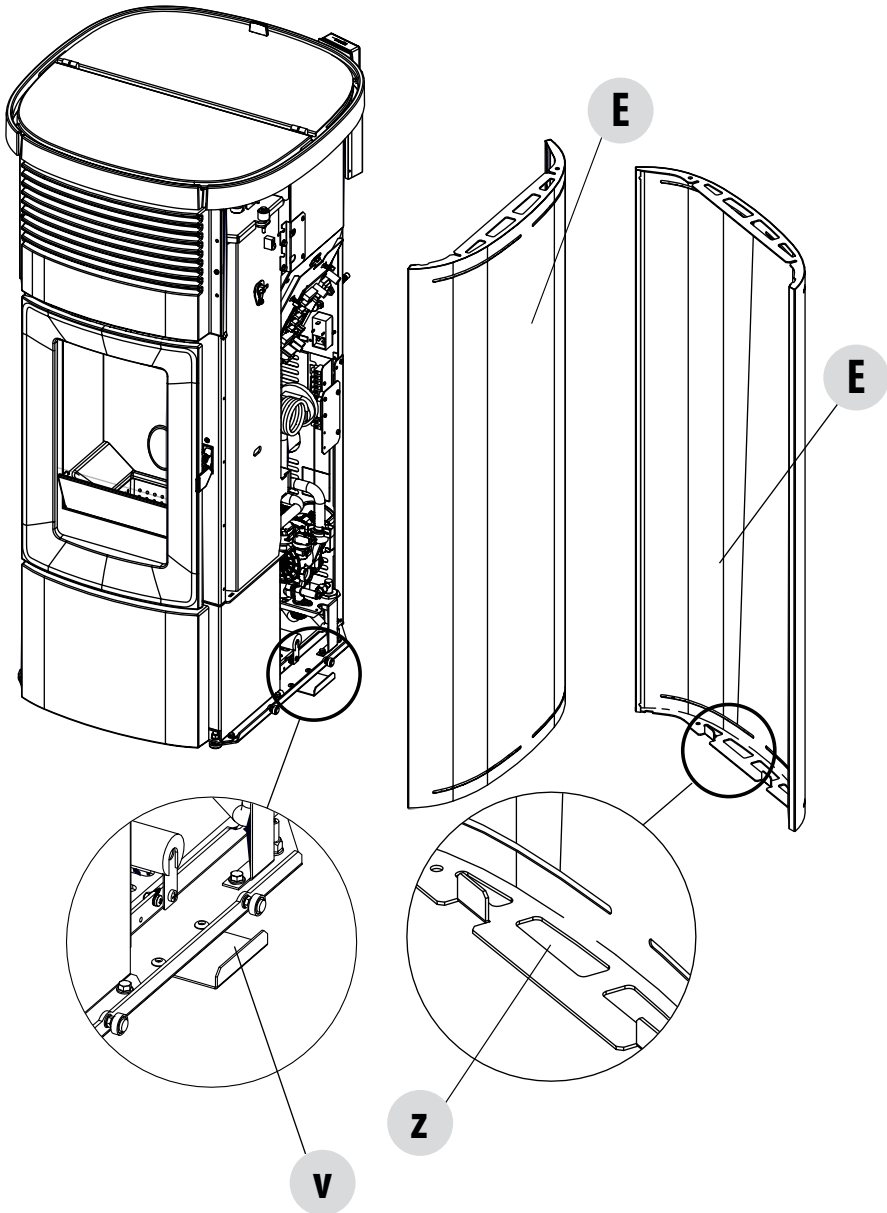

6-MUSA STOVE ASSEMBLY

From above, through the slot on the top, tighten screw "m" which has been secured to the structure before.

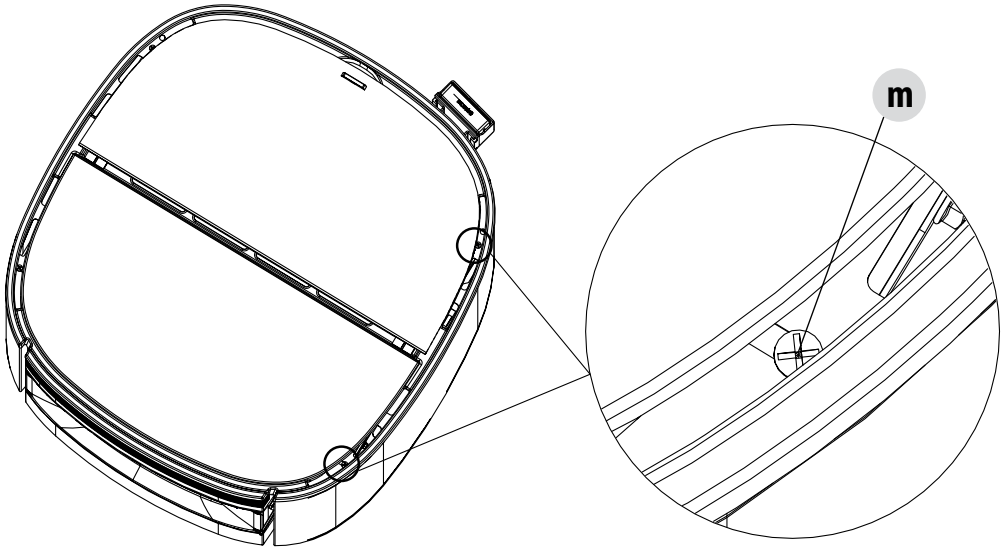

6-MUSA STOVE ASSEMBLY

In the event of assembling the panels without the top, fasten the sides to the structure from above by means of washer "n" and screw "m".

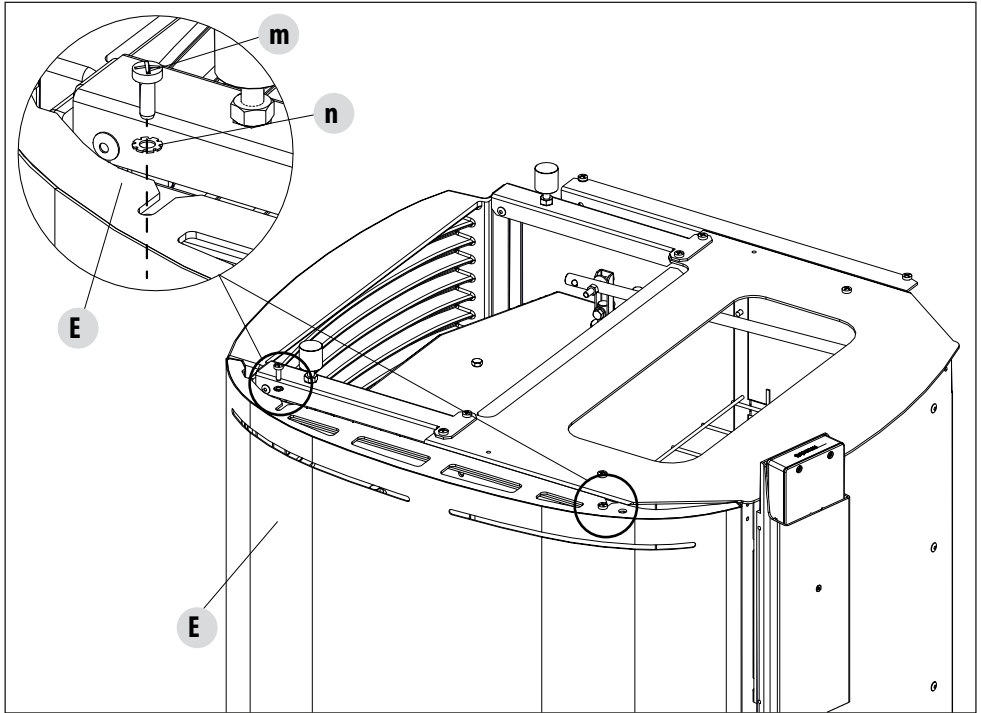

6-MUSA STOVE ASSEMBLY

Proceed with the other side "E" in the same way.

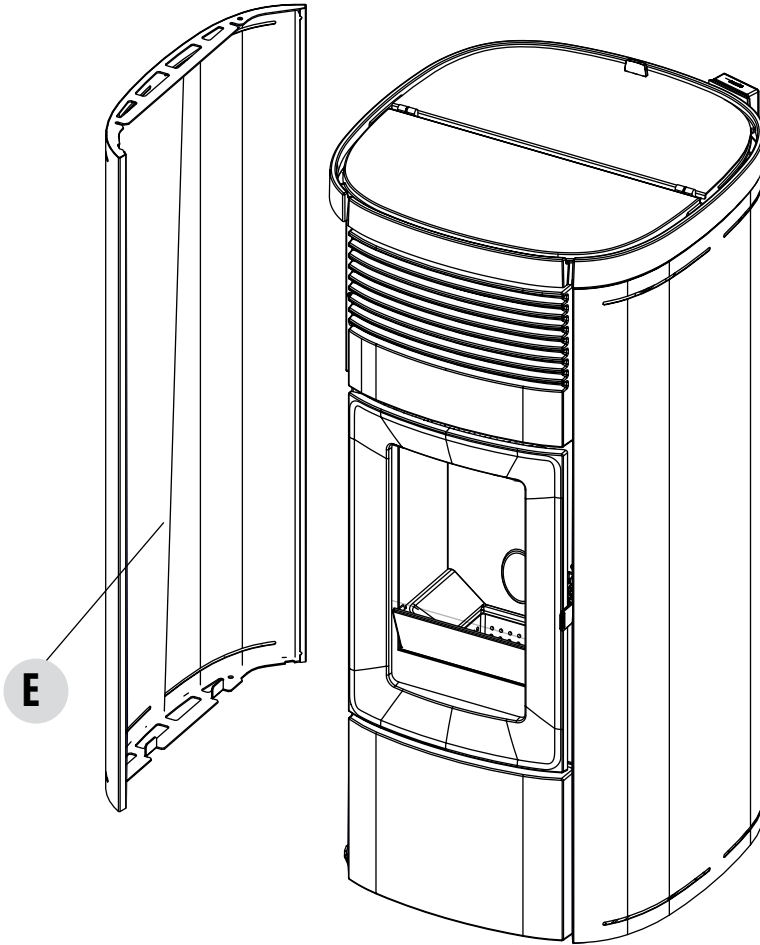

7-REAR PANEL

REAR PANEL

If maintenance must be performed on a component of the stove, the rear panel can be removed (if the distances from the walls allow it), otherwise, the maintenance can be performed by removing the side of the stove.

To remove the rear panel, remove the seven rear screws "a" and pull panel "L" away.

The "L" panel can also be removed with the stove installed since its shape corresponds with the smoke outlet pipe. Plate "L1" supports the flue pipe as it is secured to the stove using the two screws "a". With the stove installed you must only remove plate "L1" if the smoke pipe must be removed, otherwise remove only plate "L".

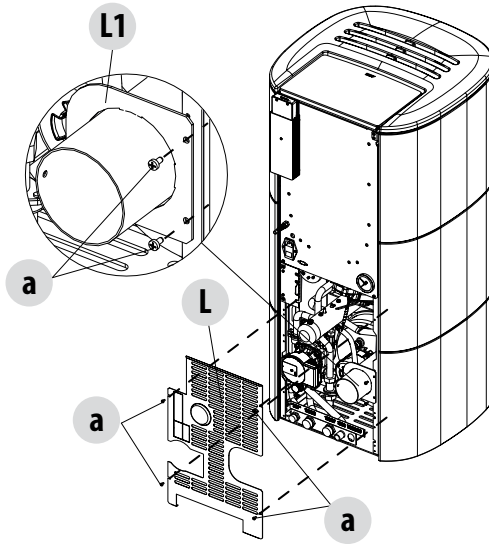

TERMINAL BLOCK ACCESS PANEL

Make the connections to the terminal block by loosening the two screws "k", grasping bracket "S" for the guide and remove the entire unit with the terminal block. Make the connections and reinstall everything.

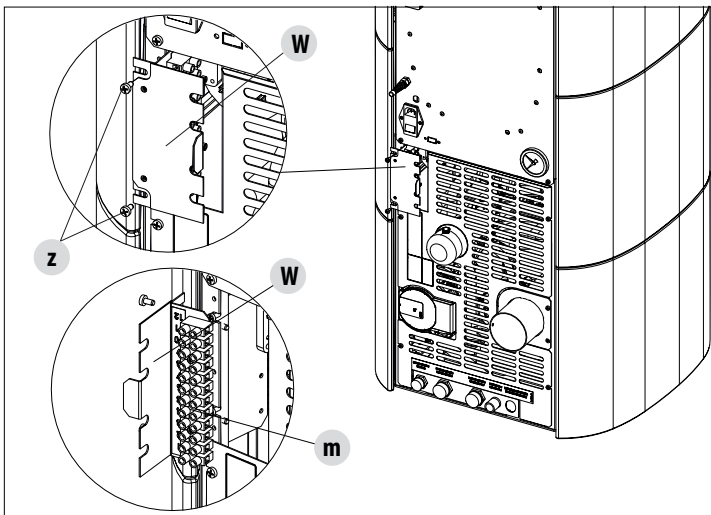

8-DOOR OPENING

OPENING THE DOOR OF THE FIREBOX

To open the firebox door "F", insert the cold handle "Z" into the hole in the handle "P" and pull it towards you.



Attention! Only open the door when the stove is off and cold.

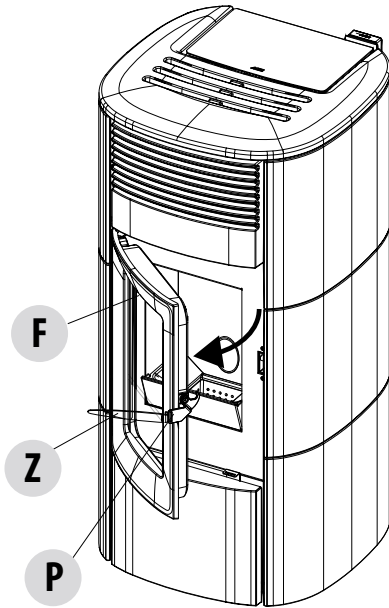

OPENING THE DOOR OF THE FIREBOX

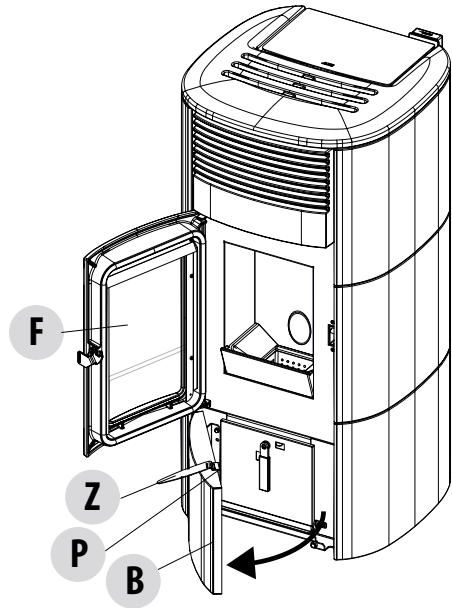

LOWER DOOR OPENING

LOWER DOOR OPENING

To open the lower door "B", insert the cold handle "Z" into the hole in the handle "P" and pull it towards you.



Attention! The lower door "B" can only be opened with the firebox door "F" open.

9-LOADING THE PELLETS

LOADING THE PELLETS

Fuel is loaded from the upper part of the stove by lifting the door "G". Pour the pellets into the hopper.

This is easier if performed in two steps:

Pour half of the contents into the hopper and wait for the fuel to settle on the bottom.

Then pour in the rest.



If loading pellets when the stove is running, open the door of the tank using the stove mitten that comes with the stove itself.

When loading, do not let the pellet bag come into contact with hot surfaces.

Never remove the protection grid inside the hopper.

No other type of fuel other than pellets is to be inserted into the hopper, in compliance with above-mentioned specifications.

Store the spare fuel at an adequate safe distance.

Do not pour pellets directly onto the brazier but only into the hopper.

When the appliance is running and when it is turned off, most of the stove surfaces are very hot (door, handle, glass, smoke outlet pipes, etc.). Therefore it is recommended to avoid coming into contact with these parts.

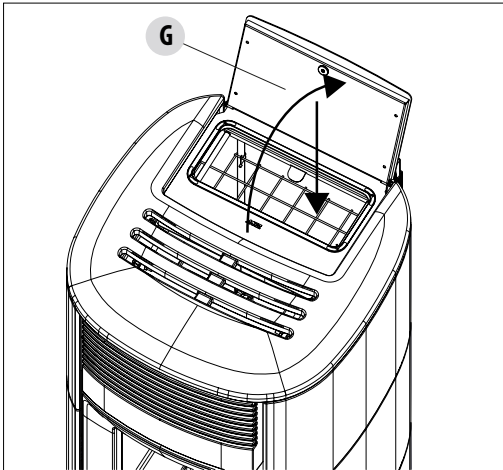

SUITE/CLUB STOVE

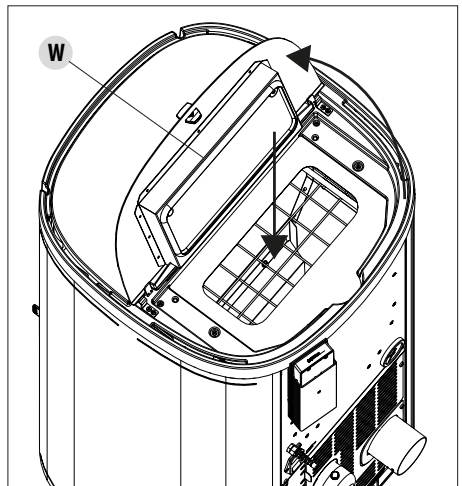

MUSA STOVE

9-LOADING THE PELLETS

SAFETY

PROCEDURE TO FOLLOW IF ANY SMOKE SPILLAGE IS SEEN WITHIN THE ROOM OR THE APPLIANCE SUFFERS FROM AN EXPLOSIVE IGNITION PLEASE TURN OFF THE APPLIANCE, VENTILATE THE ROOM AND CONTACT THE INSTALLER/ SERVICE ENGINEER IMMEDIATELY.

User Training

In ALL cases the installation and commissioning engineer MUST carry out a thorough handover of the appliance to the homeowner / end user. The following elements should be covered to the satisfaction of the end user. Failure to do this may result in unsafe use of the appliance:

- Explanation of the appliance and how it works
- Necessity to maintain ventilation to the appliance and the issues that may arise otherwise
- Fuel usage and supply
- How to light the appliance safely
- What to do in the event of failed ignitions
- What to do in the event of alarms (in particular those generated when the appliance runs out of fuel)
- How to maintain the appliance correctly and the importance of carrying out these tasks each month
- It is good practise to agree a date for the first annual service
- Explain the importance of the CO alarm in accordance with approved document J of the building regs (ONLY FOR UK)
- Explain the need for the flue draft stabiliser and its position within the flue system (ONLY FOR UK)
- Discuss the use of secondary heating systems if applicable
- Explain how the remote control or room stats operate and their optimal positioning
- Explain the need for the appliance data plate in accordance with approved document J of the building regulations (ONLY FOR UK)
- The commissioning process and paperwork should also be explained to the homeowner. A copy of the base settings on the commissioning paperwork should also be left with the appliance (ONLY FOR UK).

10-HYDRAULIC CONNECTION

PLUMBING SYSTEM CONNECTION



IMPORTANT!

The connection of the stove to the plumbing system must be carried out **ONLY** by specialized personnel who are capable of carrying out installation properly, in compliance with current standards in the country of installation. The manufacturer will not be held responsible for damage to persons or things in the event of failed operation if the aforementioned warning is not complied with.

It is important that **ONLY** qualified engineers are used to fit and commission the appliance in ALL cases. The installing engineer **MUST** hold a QCF recognised biomass qualification. Any company using sub-contractors **MUST** ensure they also hold the relevant qualifications (ONLY FOR UK).

CONNECTION DIAGRAM

- A1 Heating water supply 3/4" M
- A2 Heating water return 3/4" M
- A3 Filling the system 1/2"
- A4 System outlet Ø16

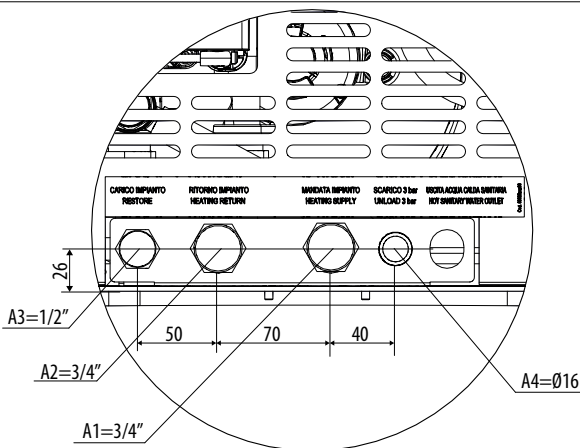
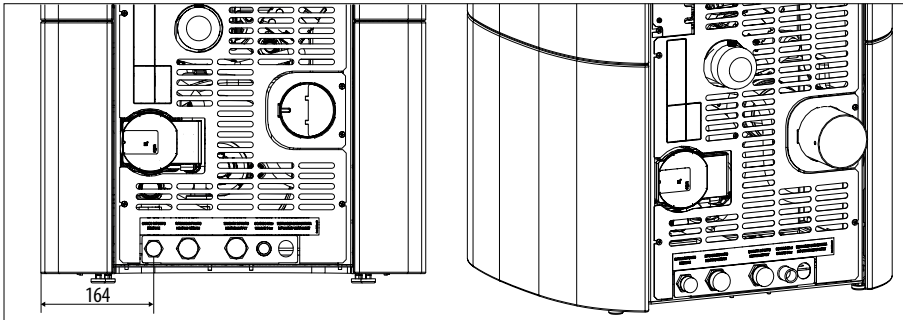

IMPORTANT!!!

CLEAN THE ENTIRE SYSTEM BEFORE CONNECTING THE STOVE, IN ORDER TO REMOVE ALL RESIDUE AND DEPOSITS. Upstream from the stove, always install shutters so as to disconnect it from the plumbing system should it be necessary to move it, or when it requires routine and/or special maintenance. Connect the stove using hoses so that the stove is not too strictly connected to the system, and to allow slight movements.

10-HYDRAULIC CONNECTION

SUITE/CLUB/MUSA STOVES CONNECTION DIAGRAM FOR DOMESTIC WATER PRODUCTION

- A1 Heating water supply 3/4" M
- A2 Heating water return 3/4" M
- A3 System filling/Domestic cold water inlet
- A4 System outlet
- A5 Domestic hot water outlet

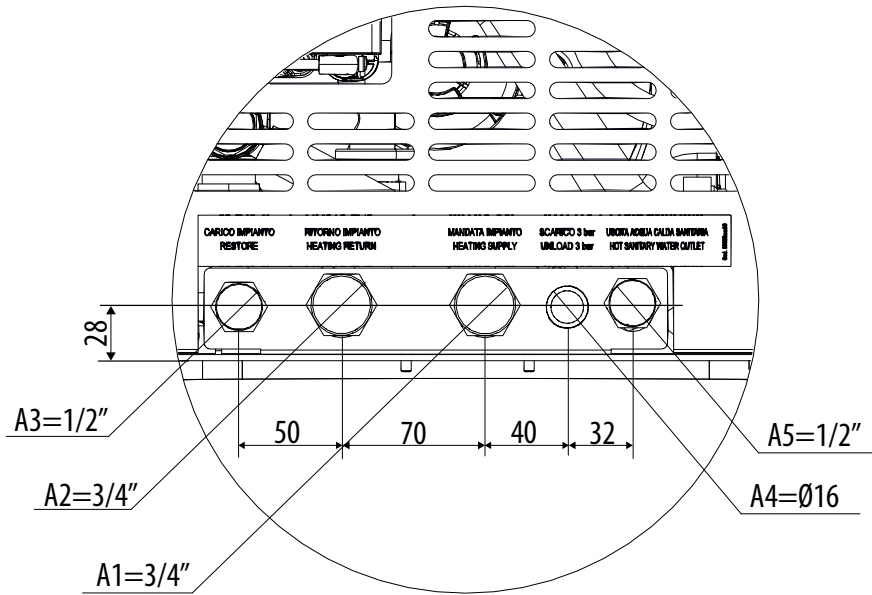
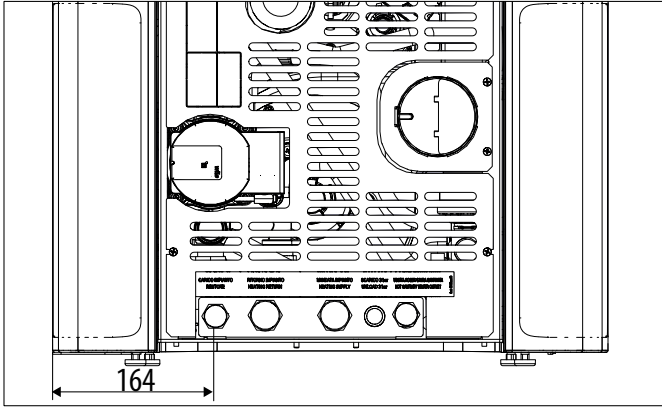

10-HYDRAULIC CONNECTION

DISCHARGE VALVE 3 bar

The safety valve that can be inspected is found on the back of the stove, under the pump. It is MANDATORY to connect the safety drain to a rubber pipe that can withstand a temperature of 110°C (not supplied) and that reaches the outside for any water outlet.



The manufacturer of the appliance is not liable for any flooding caused by the safety valves being triggered if these have not been joined properly to the outside of the product and to a proper collection and evacuation system.

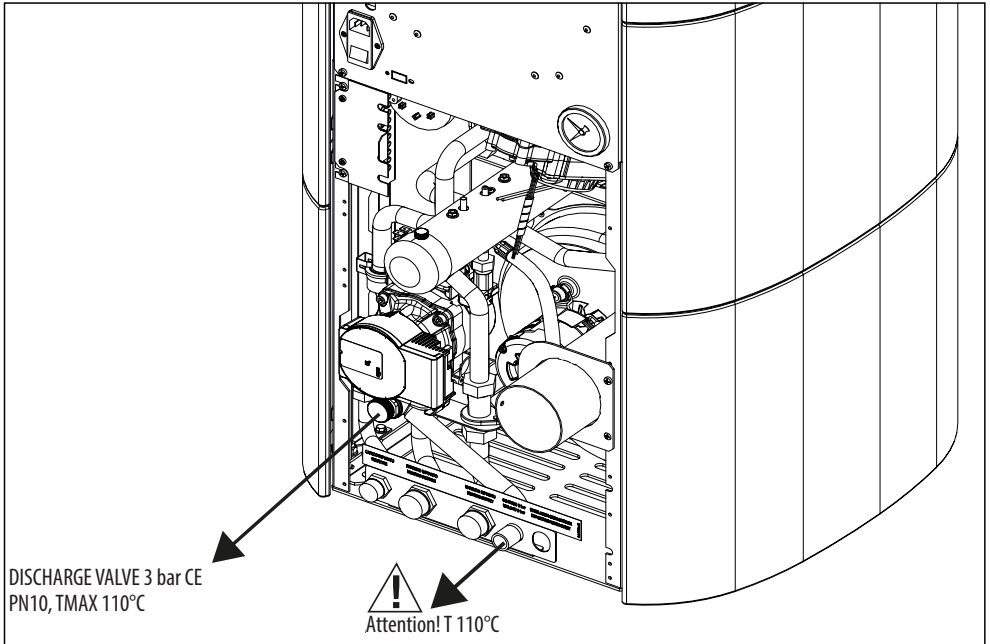

10-HYDRAULIC CONNECTION

CONNECTING THE SYSTEM

Make the connections to the corresponding fittings shown in the diagram on the previous page. Make sure the pipes are not placed under tension or undersized.



IT IS STRONGLY RECOMMENDED TO WASH THE ENTIRE SYSTEM BEFORE CONNECTING THE STOVE IN ORDER TO GET RID OF RESIDUES AND DEPOSITS.

Upstream from the stove, always install shutters so as to disconnect it from the plumbing system should it be necessary to move it, or when it requires routine and/or special maintenance. Connect the stove using hoses so that the stove is not too strictly connected to the system, and to allow slight movements.

The pressure discharge valve (C) is always connected to a water drain pipe. The pipe must be adequate to support the water's high temperature and pressure.

CLEANING THE SYSTEM

It is mandatory for the connections to be easy to disconnect by way of unions with rotating connection.

Install suitable shutters to cut off the tubes from the heating system. Assembling the safety valve on the system is compulsory.

In order to protect the heating system from damage caused by corrosion, incrustation or deposit build-up, it is important to clean the appliance before installation, using suitable products, in compliance with Standard UNI 8065 (water treatment of thermal plants for civil use).

The use of FERNOX PROTECTOR F1 (available at our authorised centres) product is recommended, this provides long term protection against corrosion and calcium build-up for heating systems. It prevents the corrosion of the metal parts of the appliance, i.e. the ferrous metals, copper and copper and aluminium alloys. It also reduces the noise produced by the boiler. Refer to the instructions on the product. Cleaning should be performed by a qualified technician.

We also recommend the use of FERNOX CLEANER F3 and LEAK SEALER F4, always available from our authorised distribution centres.

FERNOX F3 is a neutral product for rapid and efficient cleaning of heating appliances. It has been designed to eliminate residues, oily deposits and incrustations from existing appliances of all ages. It can help restore the heating efficiency of the boiler and reduce the noise it generates.

FERNOX F4 is intended to be used with all heating appliances to seal micro fractures that cause small and inaccessible leaks.

FILLING THE SYSTEM

To fill the system, the stove can be equipped with an end piece (optional) with a non-return valve (D) for manual filling of the heating system (if the optional is not installed, the filling tap on the main boiler will be used). During this operation, any air in the system is released from the automatic vent valve located under the top.

To ensure the valve vents, it is advisable to loosen the grey cap one turn and leave the red cap blocked (see figure). Set the filling pressure of the system WHEN COLD to 1 bar (100 kPa). During operation, if the system pressure drops (due to evaporation of dissolved gases in the water) to values lower than the minimum indicated above, the user must use the filling tap to bring the pressure back up to its normal pressure.

To ensure correct stove operation, the maximum pressure in the system WHEN HOT must not exceed 1.5 bar (150 kPa).



Fit the system with a 2 bar safety valve connected to an accessible outlet.

To monitor the system pressure, the terminal (optional) is equipped with a manometer (M).

Upon completion of this operation, always close the tap.



It is normal to hear noises and gurgling until all the air in the system is released.

10-HYDRAULIC CONNECTION

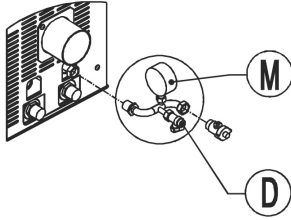

END PIECE WITH A FILLING TAP (D) AND PRESSURE GAUGE (M) (ACCESSORY)

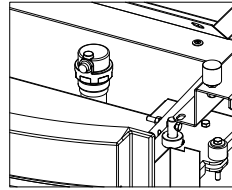

VENT VALVE UNDER THE TOP

WATER CHARACTERISTICS

The characteristics of the water used to fill the system are very important to prevent the build-up of mineral salts and the formation of incrustations along the pipes, in the boiler and in the heat exchangers.

Therefore, please GET YOUR PLUMBER'S ADVICE CONCERNING:

- **Hardness of water circulating in the system, to prevent problems of incrustation and limescale, especially in the domestic water heat exchanger. (> 25° French).**
- **Installation of a water softener (if water hardness exceeds 25° French).**
- **Filling the system with treated water (demineralised).**
- **Possibly providing an anti-condensation circuit.**
- **Installation of plumbing bumpers to prevent banging along the fittings and pipes.**

If you have very extensive systems, with a large amount of water, or which require frequent refilling, the installation of water softening systems.



It should be remembered that incrustations drastically reduce performance due to low thermal conductivity.

11-ELECTRICAL CONNECTION

ELECTRICAL CONNECTION

First connect the power cable to the back of the stove and then to a wall socket.

The main switch must only be activated to switch the stove on; otherwise, it is advisable to keep it switched off.



It is recommended to disconnect the power cable when the stove is not used.

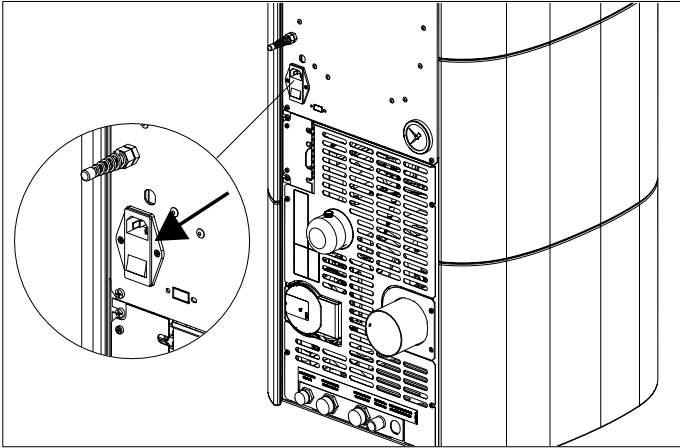

ELECTRICAL STOVE CONNECTION

STOVE POWER SUPPLY

After connecting the power cable to the back of the stove, turn the switch at the back to position (I).

The luminous switch button will light up.

The switch on the back of the stove is used to power the system.

On the rear of the stove there is a fuse holding compartment which is located underneath the supply socket. Use a screwdriver to open the fuse-holder compartment and if necessary replace them (3.15 A delayed)

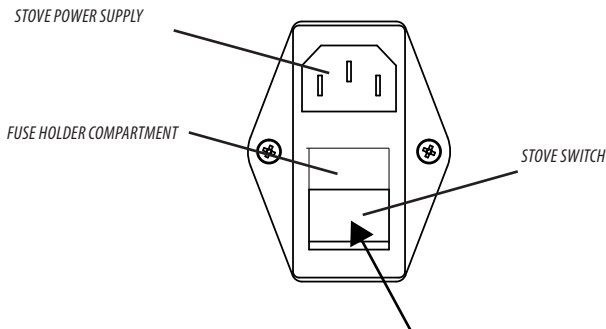

11-ELECTRICAL CONNECTION

USB SOCKET

There is a USB socket on the back of the stove, if a software update is required; the ceramic/metal parts do not have to be removed to reach the socket directly in the circuit board (pos. 20 in the PCB).



Attention!

The USB socket must be used by skilled technicians.

Risk of damaging the product.

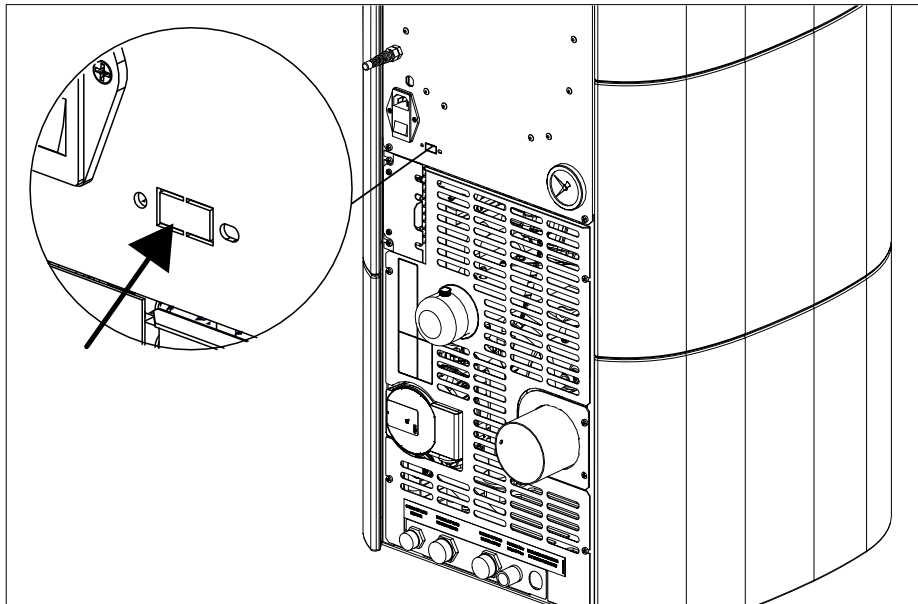



MCZ

MCZ GROUP S.p.A.

Via La Croce n°8

33074 Vigonovo di Fontanafredda (PN) – ITALY

Telephone: 0434/599599 a.s.

Fax: 0434/599598

Website: www.mcz.it

e-mail: mcz@mcz.it