

PELLET BOILER STOVE

## BLADE H 18-22



## CONTENTS

Introduction and readers of this manual	3
Safety information	4
Dimensions	5
Technical data	7
Unpacking	8
Water circuit installation	9
Terminal board	14
Installation	15
Installation of steel lining	19
Installation of ceramic lining	26
Introduction about use	31
Display	32
Operational logic	34
Commands and Menu	37
Stand By	38
Crono	39
Temperatures	42
Ventilation, Pellet Load, Language	43
Beep, Date/Time, Pressure, Technical Menu	44
Maintenance	45
Troubleshooting	48

*The original language of this manual is Italian*

The undersigned EDILKAMIN S.p.A., with registered office in Via Vincenzo Monti 47 - 20123 Milan (Italy) - Tax ID Code and VAT number 00192220192

Hereby declares, under its sole responsibility, that:  
the pellet boiler stoves mentioned below are conforming with EU Regulation 305/2011 and harmonised EU standard EN 14785:2006

PELLET BOILER STOVES, bearing the EDILKAMIN trademark, models BLADE H 18 e BLADE H 22

SERIAL NO.: Rating plate reference  
BLADE H 18 : Performance declaration (DoP - EK no. 154)  
BLADE H 22 : Performance declaration (DoP - EK no. 155)

Moreover, the company hereby declares that:  
the wooden pellet boiler stoves BLADE H 18 e BLADE H 22 comply with the requirements in the following European Directives:  
2014/35/EC - Low Voltage Directive  
2014/30/EC - Electromagnetic Compatibility Directive

Dear Sir/Madam

We thank you for and congratulate you on choosing our product. Before using it, we ask you to read this manual carefully, in order for you to be able to make the most of all its functions in total safety.

This manual is an integral part of the product. We ask you to keep it for the entire lifetime of the product. If you lose it, you can request a copy from your dealer or download it from [www.edilkamin.com](http://www.edilkamin.com)

### Readers of this manual

This manual is addressed to:

- those who will use the product at home ("USER");
- the technician who will install the product ("INSTALLER")

The target person of each page is indicated in a band at the bottom of the page (USER or INSTALLER).

### General information

After unpacking the product, check the condition and completeness of the contents.

In the event of error, immediately contact the retailer where the purchase was made, providing them with a copy of the warranty booklet and the sales receipt.

The appliance must be installed and operated in compliance with local and national law and European regulations. For the installation, and for anything not specifically indicated in the manual, observe local regulations.

The diagrams provided in this manual are for illustration purposes only: they do not always strictly refer to your specific model, and are not binding in any way.

### Identification of the product and warranty.

The product is uniquely identified by a number, the "counterfoil", which is indicated on the warranty certificate.

Please keep:

- the warranty certificate accompanying the product
- the purchase receipt given to you by the retailer
- the declaration of conformity given to you by the installer.

The warranty conditions are given in the warranty certificate accompanying the product.

**First ignition (commissioning)**, in Italy, by an authorised technician is required by UNI 10683, and is recommended in all countries to ensure best results from the product.

This consists of:

- checking the installation documents (declaration of conformity) and the quality of the installation itself
- calibrating the product to suit its actual application
- providing explanations to the end user and issuing the complementary documentation (first ignition - commissioning certificate)

Having the appliance commissioned properly ensures that it will operate to best effect and in complete safety.

Commissioning is required for activation of the Edilkamin manufacturer warranty. The warranty is only valid in the country where the product was bought.

If the appliance is not commissioned by an authorised technician, Edilkamin will not provide warranty service. See the warranty booklet for details. The above terms do not affect the dealer's legal responsibility for the legal warranty.

The warranty, however, covers only demonstrable manufacturing defects and not, for instance, problems resulting from improper installation or calibration.

#### MEANING OF SYMBOLS

In some parts of the manual the following symbols are used:



#### PLEASE NOTE:

carefully read and understand the message in question, since failure to follow the instructions in it could cause serious damage to the product and put the safety of those using it at risk.



#### INFORMATION:

failure to comply with these requirements will compromise product use.



#### OPERATING SEQUENCE:

follow the instructions for the operations described.

- The product is not designed for use by people, including children, with limited physical, sensory and mental abilities.
- The appliance is not designed for cooking purposes.
- The appliance is designed to burn wood pellets from category A1 in the UNI EN ISO 17225-2 standard, in the amounts and manner described in this manual.
- The appliance is designed for indoor use and in areas with normal humidity conditions.
- Keep the product in a dry place out of the weather.
- For the legal and company warranties, refer to the warranty certificate inside the product: specifically, neither Edilkamin nor the retailer are liable for damage resulting from incorrect installation or maintenance.

Safety risks may be caused by:

- installation in non-suitable settings, in particular those that are subject to fire risks. **DO NOT INSTALL THE PRODUCT IN AREAS SUBJECT TO THE RISK OF FIRE.**
- contact with fire and hot parts (e.g. glass panel and pipes). **DO NOT TOUCH HOT PARTS** and, when the stove is switched off and still hot, always wear the glove supplied.
- contact with live electrical equipment (internal). **DO NOT ACCESS THE INTERNAL ELECTRICAL EQUIPMENT WHILE THE APPLIANCE IS POWERED ON.** Electrocutation hazard.
- use of improper ignition aids (e.g. alcohol). **DO NOT IGNITE OR BOOST THE FLAME WITH FLUID SPRAYS OR A FLAME TORCH.** Serious risk of burns, damage and injury.
- use of fuel other than wood pellets. **DO NOT BURN WASTE MATTER, PLASTIC OR OTHER MATERIALS THAN WOOD PELLETS IN THE COMBUSTION CHAMBER.** The product may become soiled, the flue may catch fire, and environmental damage may ensue.
- cleaning the combustion chamber when hot. **DO NOT CLEAN THE**

**HEARTH WITH A VACUUM CLEANER WHILE IT IS HOT.** You could damage the vacuum-cleaner and risk the emission of smoke in the room.

- cleaning the smoke duct with cleaning products. **DO NOT CLEAN THE PRODUCT WITH FLAMMABLE PRODUCTS.** Risk of fire or blowback.
- cleaning the glass pane while hot or with unsuitable cleaning products. **DO NOT CLEAN HOT GLASS WITH WATER. ONLY USE RECOMMENDED GLASS CLEANING PRODUCTS.** Risk of cracking and permanent, irreparable damage to the glass.
- the storage of flammable materials at a distance which is less than the safe distances listed in this manual. **DO NOT PLACE LAUNDRY ON THE APPLIANCE. DO NOT PLACE DRYING RACKS WITHIN THE SAFETY CLEARANCE.** Keep flammable fluids away from the appliance. Fire hazard.
- blocking the aeration vents and air intakes in the room. **DO NOT BLOCK THE AERATION VENTS OR FLUE.** Risk of smoke returning into the room with consequent damage and injury.
- use of the product as a support or ladder. **DO NOT CLIMB ONTO THE PRODUCT OR USE IT AS A SUPPORT.** Risk of damage and injury.
- use of the stove with the combustion chamber open. **DO NOT USE THE PRODUCT WITH ITS DOOR OPEN.**
- incandescent material projected from the open door. **DO NOT throw incandescent material outside the appliance.** Fire hazard.
- use of water in case of fire. **CALL THE AUTHORITIES** if a fire breaks out.
- never operate the product without water in the circuit.
- running it dry can damage it.

If you have doubts, please do not take any action, but contact the retailer or the installer.

For reasons of safety, read the user instructions included in this manual.

BLADE H 18-22 STEEL (cm)

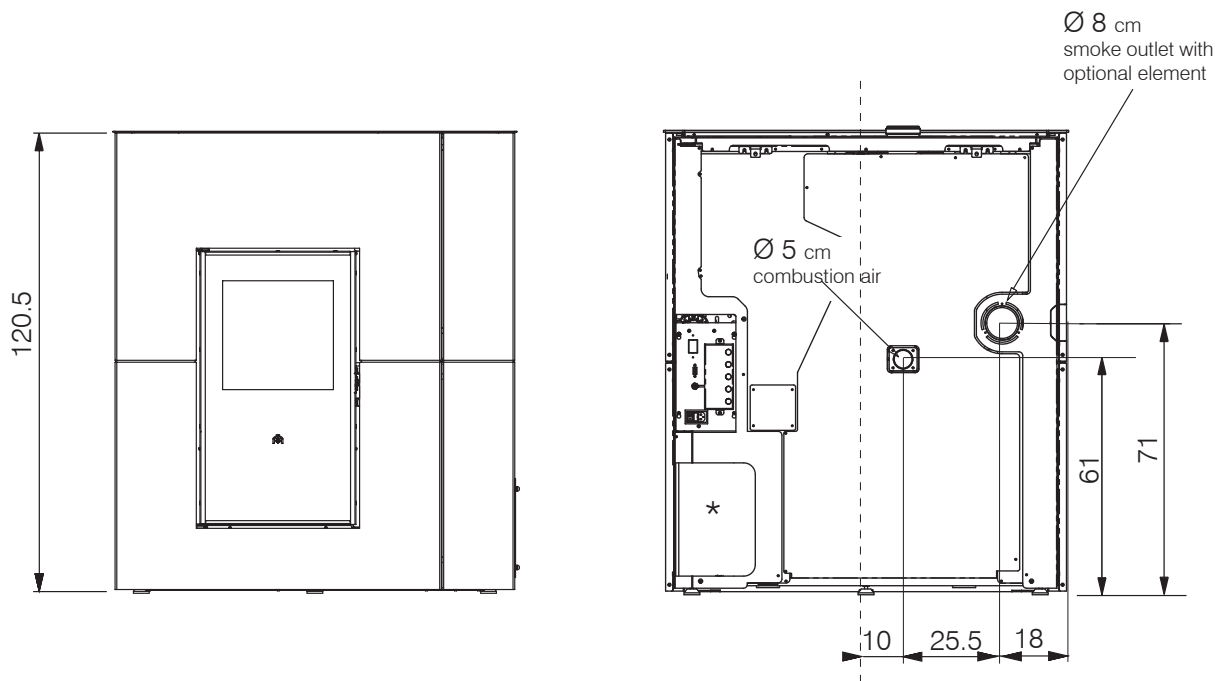

\* space for housing the R, R2 or RW (Blade H22) hydraulic kit. Information on the kit manual.

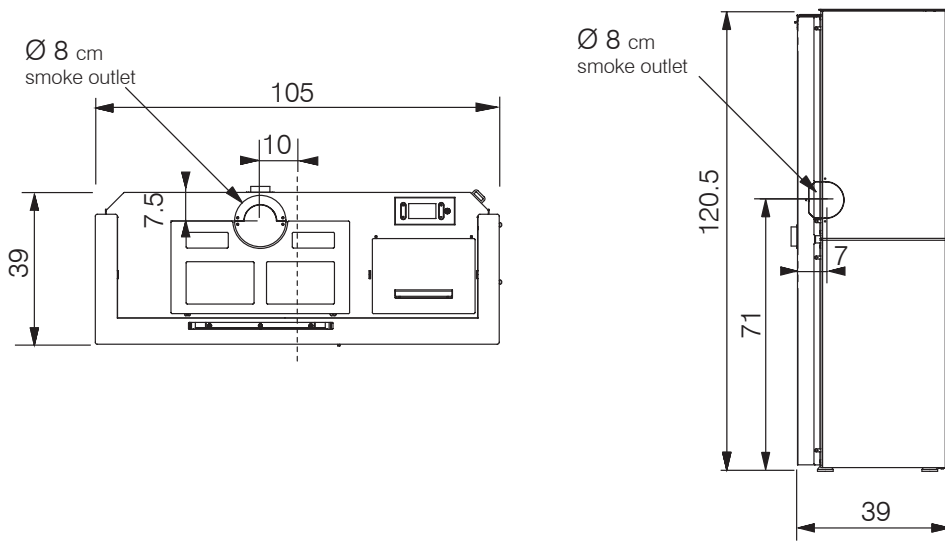

The boiler stove is supplied standard with the top smoke outlet female. An optional kit is available for the rear or side smoke outlet.

BLADE H 18-22 CERAMIC (cm)

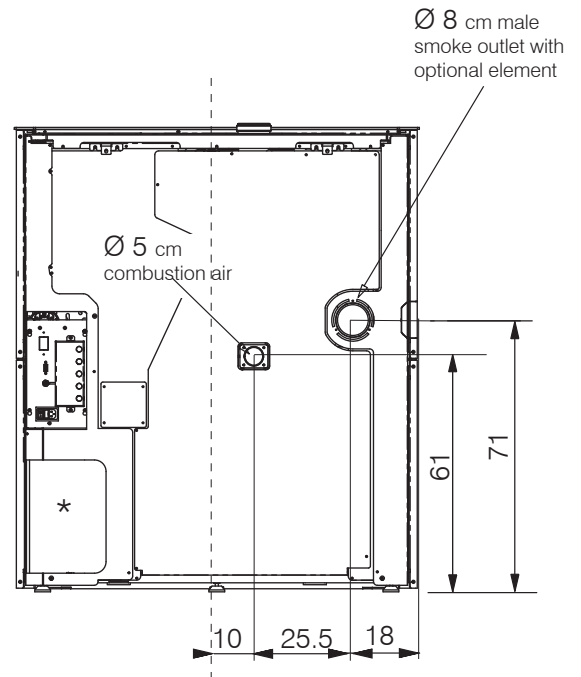
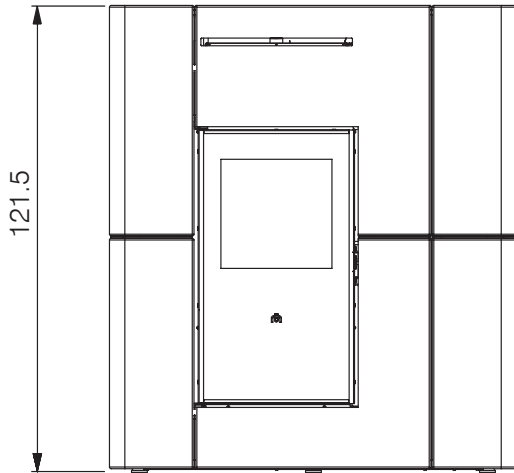

\* space for housing the R, R2 or RW (Blade H22) hydraulic kit. Information on the kit manual.

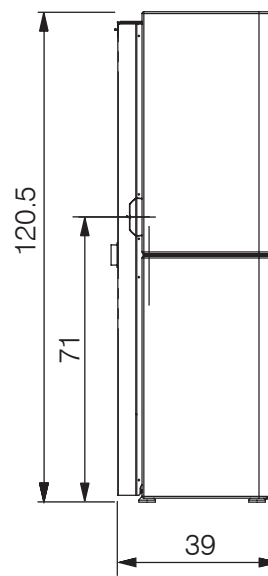
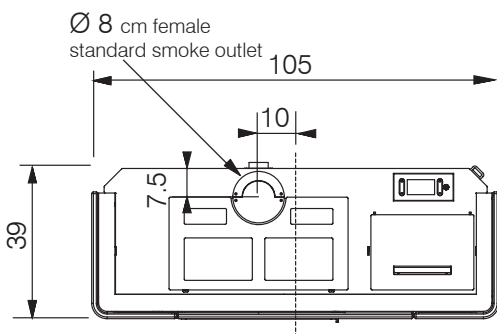

The boiler stove is supplied standard with the top smoke outlet female. An optional kit is available for the rear smoke outlet.

<b>TECHNICAL SPECIFICATIONS as per EN 14785</b>				
	<b>BLADE H 22</b>	<b>BLADE H 18</b>	<b>BLADE H 18-22</b>	
	Nominal power		Reduced power	
Available power	22.5	18.7	4.9	kW
Power available to water	20	16.3	3.8	
Efficiency	92.7	93.3	95.1	%
CO emissions at 13% O <sub>2</sub>	0.012	0.013	0.007	%
Fumes temperature	114	101	54	°C
Fuel consumption	5.1	4.2	1.1	kg/h
Tank capacity	30			kg
Recommended draught	11	11	11	Pa
Autonomy	6	7	26	hours
Water content	20			l
Maximum operating pressure	2			bar
Maximum operating temperature	90			°C
Heatable volume *	585	485		m <sup>3</sup>
Fume duct diameter (female)	80			mm
Air intake duct diameter (male)	50			mm
Weight with packaging (ceramic/steel)	280			kg

\* The heatable volume is calculated for a house insulated pursuant to Italian Law 10/91 and subsequent amendments, and a heating demand of 33 kcal/m<sup>3</sup> hour.

<b>TECHNICAL DATA FOR SIZING THE FLUE</b>			
which must nonetheless satisfy the requirements of this sheet and the product's installation instructions			
	Nominal power		
	<b>BLADE H 22</b>	<b>BLADE H 18</b>	
Fume temperature at smoke outlet	137	122	°C
Minimum draught	0.01		Pa
Fume flow rate	15.1	13.4	rps

<b>ELECTRICAL SPECIFICATIONS</b>	
Power supply	230 V AC +/- 10% 50 Hz
Mean absorbed power	50-80 W
Power absorption during ignition	300 W
Protection rating	Fuse 4 AT 250 V AC 5x20

The above data is for guidance only and was measured during certification by a notified body. EDILKAMIN S.p.A. reserves the right to modify the product without notice for the purpose of improving it.

**PREPARATION AND UNPACKING**

The packaging materials are neither toxic nor noxious and do not require special disposal. The user is responsible for storing, disposing of and recycling them in conformity to the applicable laws.

**PACKAGING****BLADE H STEEL**

One item contains:

- the stove structure;
- the box with the steel claddings.

**BLADE H CERAMIC**

One item contains:

- the stove structure;
- a box with the metal parts;
- two boxes strapped together each containing a ceramic side panel.

Inside the product you will find: the warranty certificate, glove, this manual, power cable, two wall-mounting brackets. The removable handle for opening the door is located on the pallet.

**TO REMOVE THE PALLET (ALL MODELS)**

The stove is secured to the pallet with four brackets: two at the front and two at the back.

Undo the two screws on each bracket



Use appropriate equipment to shift the product while keeping it in the vertical position. Observe all applicable safety regulations.

Take care not to tip the product.

**ADJUSTABLE FEET**

The Blade H boiler stoves have adjustable feet to adapt to uneven floors.

The feet can be adjusted by slightly raising the boiler stove or using a screwdriver from above the foot.

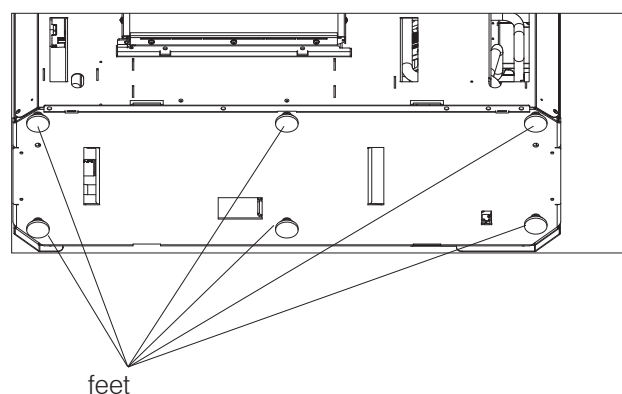

The drawings are for guidance only, useful for the installation, but they may not refer to the specific model.

**WALL MOUNTING**

Mount the stove to the wall with the plates provided (a) and the brackets (b) already mounted on the product, or use alternative systems that guarantee that the product remains stable.

Fix the brackets to the wall using wall plugs.

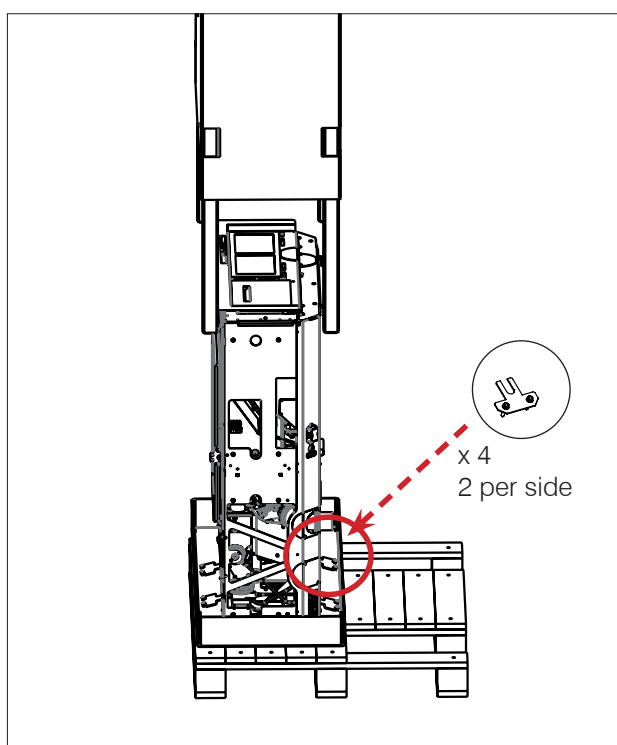
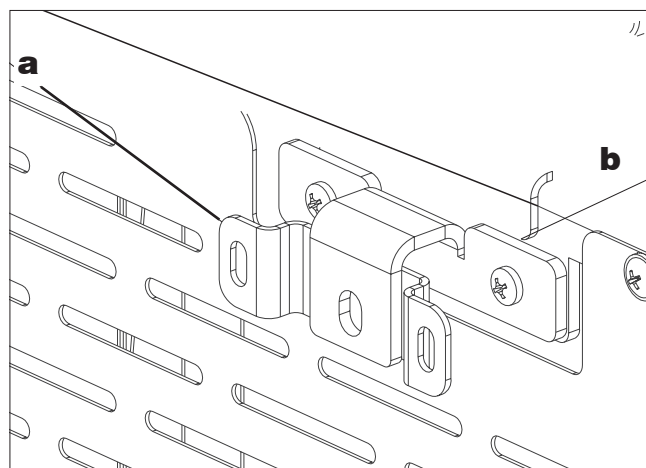



**PLUMBING**

Vyda H and Kira H are provided with a closed expansion tank.

The built-in expansion tank does NOT ensure proper protection of the water in the entire system from thermal expansion.

Therefore, installers should assess whether an additional expansion tank is needed, depending on the type of system.

ALL OTHER HYDRAULIC COMPONENTS MAY BE INSTALLED WITHIN THE BOILER STOVE BY PURCHASING A KIT FROM EDILKAMIN OR IF PREPARED BY THE INSTALLER.

Plumbing depends on the type of system.

However, there are some “general rules”:

- The hydraulic system must operate at a pressure between 1 and 1.5-2 bar at running temperature (hot) in a closed vessel circuit.
- DO NOT install the boiler stove as a replacement in a system with an open expansion tank.
- The presence of an accumulator (tank) is recommended but not mandatory. Its advantage is that it releases the boiler stove from “sudden” requests from the system and can be integrated with other heat sources. It reduces fuel consumption and increases the efficiency of the system. Edilkamin recommends an accumulator of at least 20 l/kW.
- The return temperature of water to the boiler stove must be higher than 50-55° C to prevent the formation of condensation.
- An accumulator (tank) is needed to heat low-temperature radiant panels and must be installed according to the panel manufacturer's instructions.
- The material used in the circuit must be suitable to withstand overheating.
- The installer must determine whether or not to use conditioned products. In Italy, refer to UNI 8065 (Water treatment in heating systems for civil use).
- Direct plumbing to radiators prevents proper operation, owing to the small diameter of their pipes.

Real size templates are available for technicians.

Edilkamin offers four internal kits (optional)

**R KIT**

for installations without the production of instant domestic hot water.

**R2 KIT**

For installations without the production of instant domestic hot water with system separator.

**RW KIT** (Blade H 22)

For installations with the production of instant domestic hot water. Recommended for 22 kW models only.

**PRESSURE GAUGE**

Kits are provided with an electronic reading system for water pressure. Therefore, there is no analogue pressure gauge. Water pressure is shown on the display, on the bottom left (\*) as indicated in the figure below. Edilkamin proposes an analogue pressure gauge as optional.



**i** **check that the swivel nut (G) on the two output pipes of the boiler stove are closed**

**i** **VENT**  
 During normal operations the vent is automatic. During installation, the technician must check the functionality of the automatic vent and assess whether a manual vent needs to be installed.

R-RW KIT Hydraulic connections template in mm

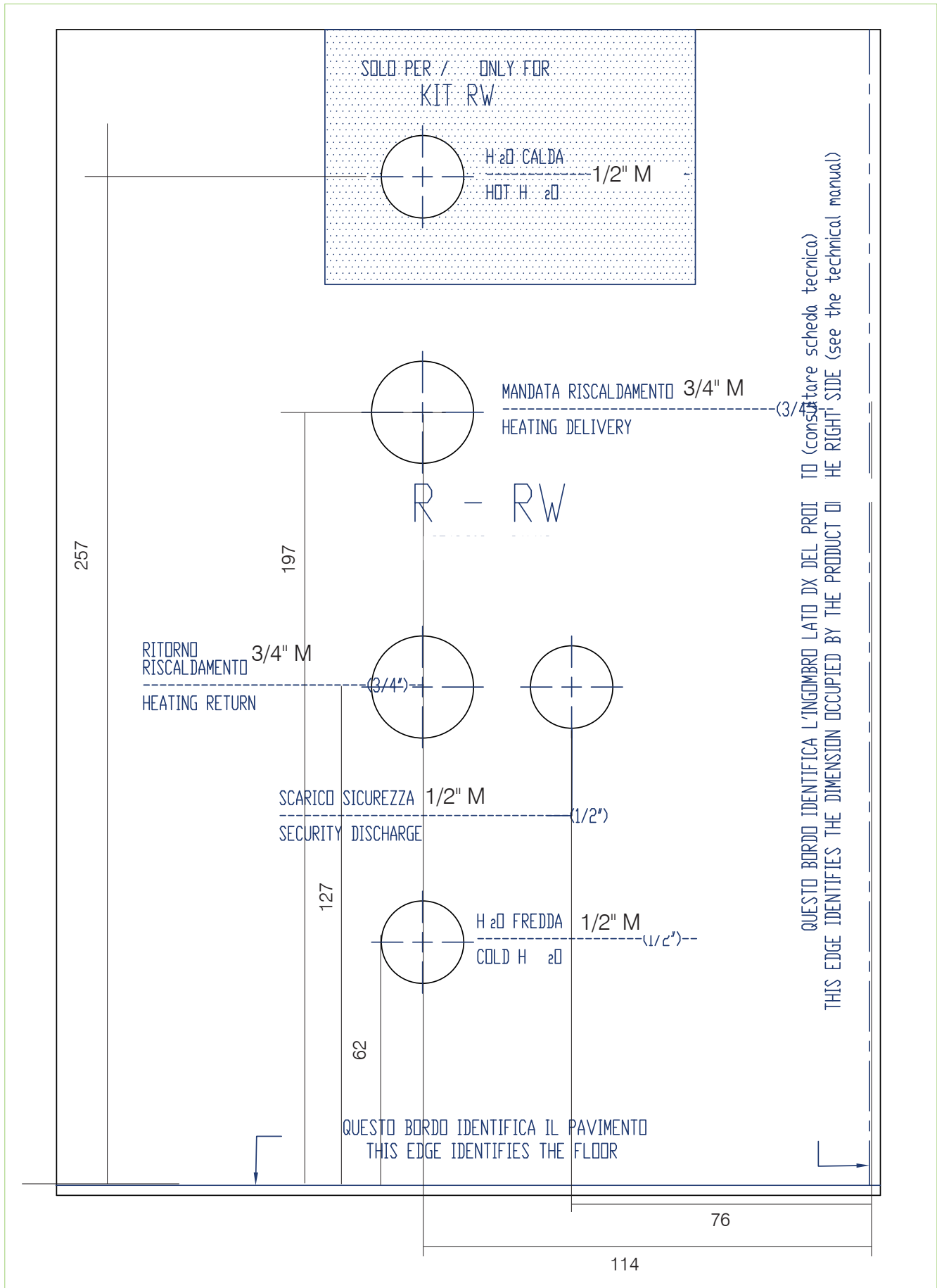

# WATER CIRCUIT INSTALLATION

R2 KIT Hydraulic connections template in mm

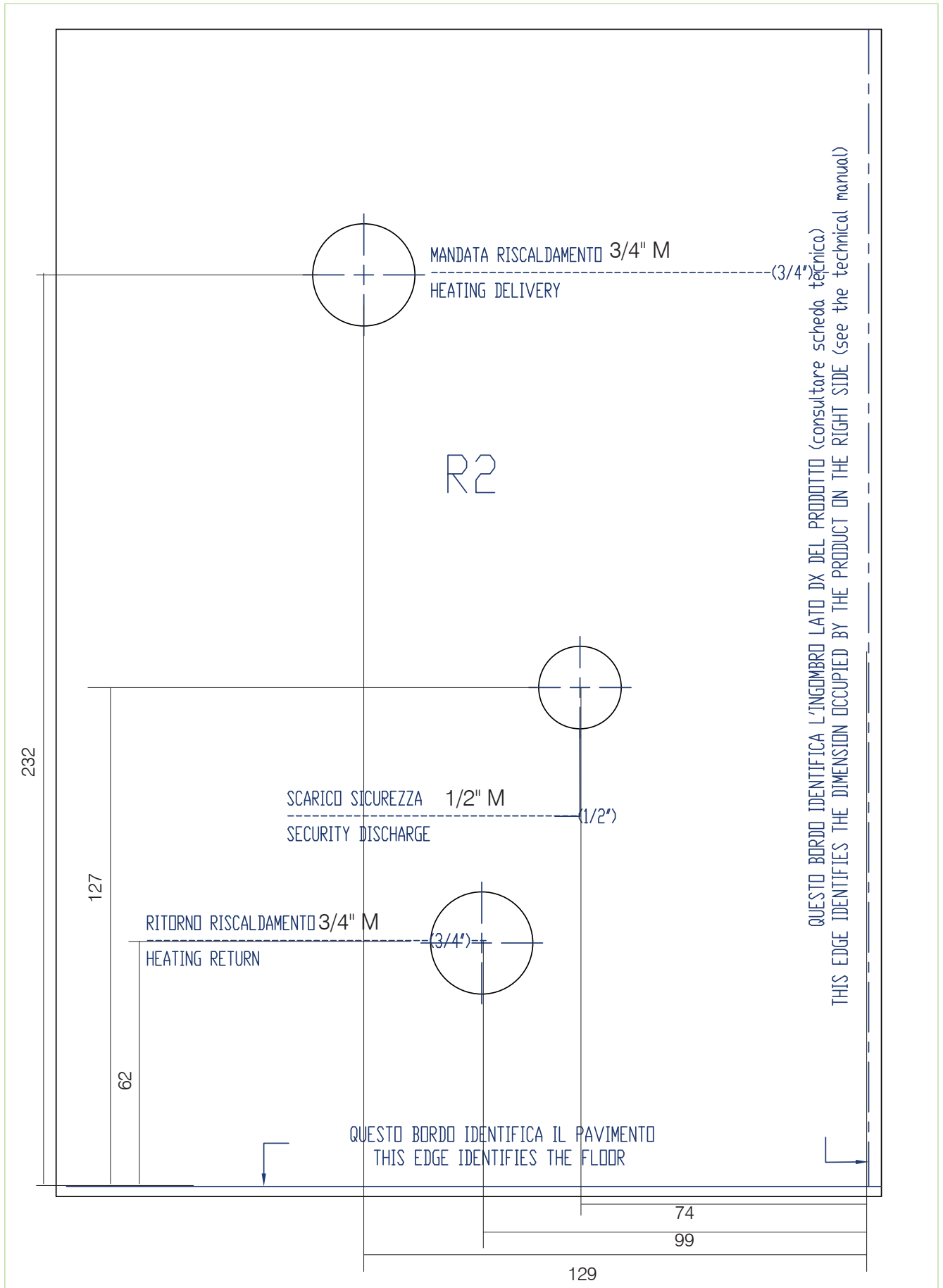

**RIGHT-HAND SIDE HYDRAULIC FITTINGS**

To have the hydraulic fittings on the right-hand side, it is possible to use commercial elbows and “exploit” the “recess” (“indent”) between the pipes’ outlet and the rear of the stove, as shown in the figure below.

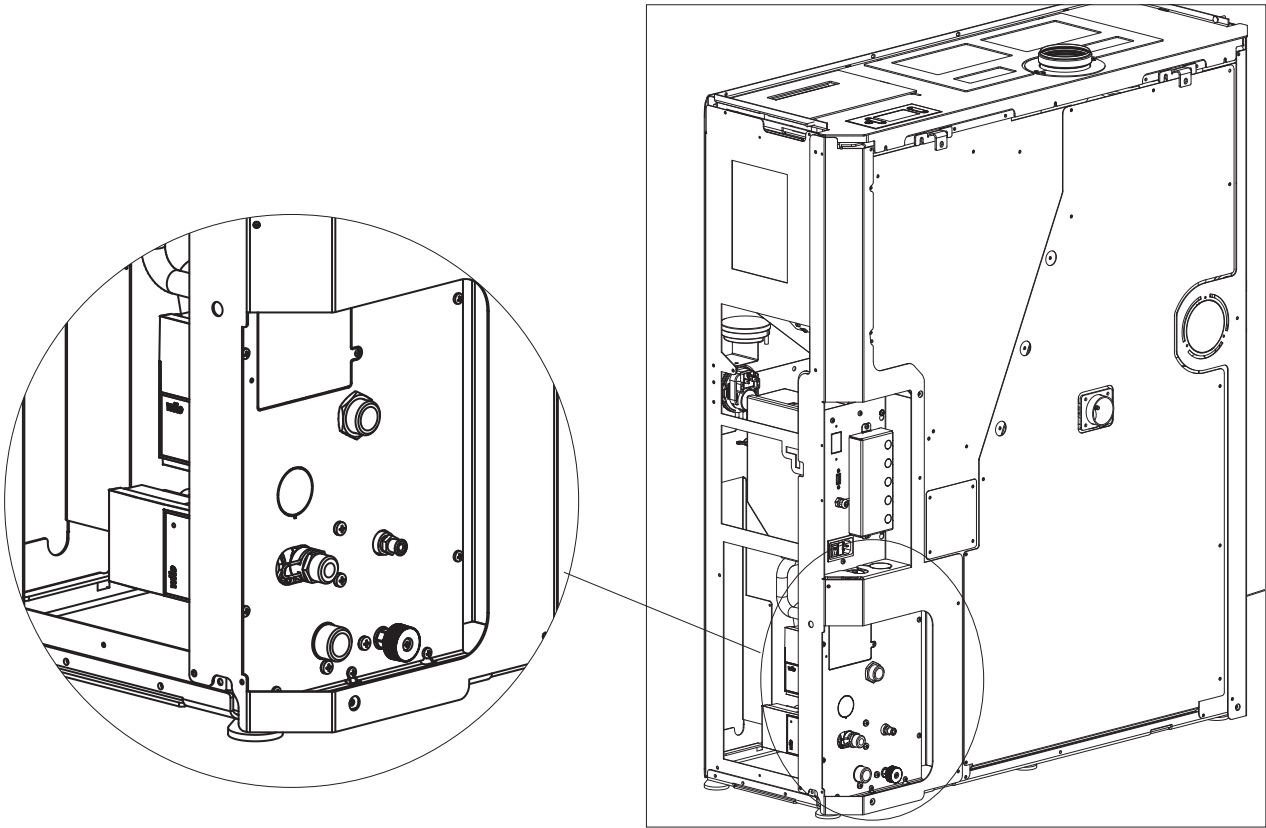

ENGLISH

12



**When installing the kit, remove the rear and verify that the swivel nuts on the boiler stove’s outlet pipes are closed.**

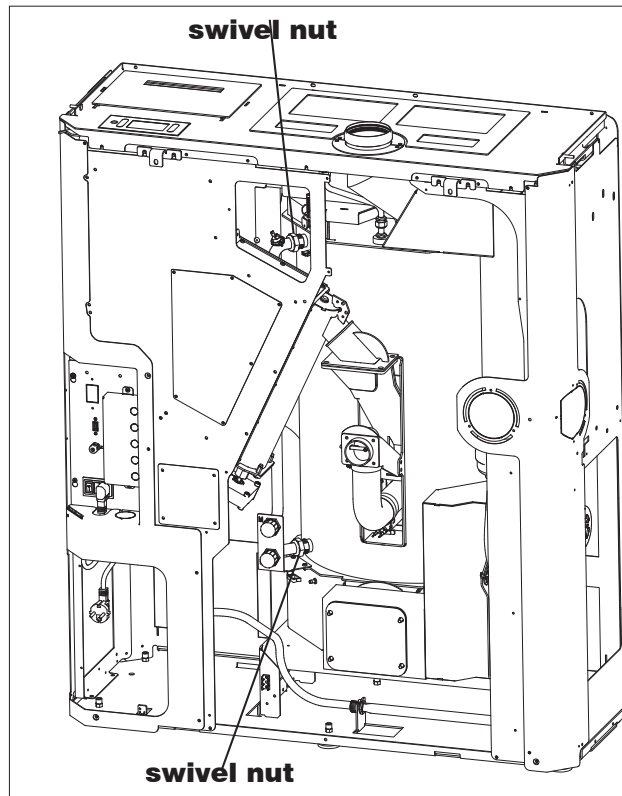

**INSTALLER**

**OPTIONAL HYDRAULIC KIT** All kits are supplied with instructions for their connection to the boiler stove. Edilkamin technicians have a paper template suitable for each product. Make sure the correct one is used for the product being installed.

Position the template so as to be flush with the floor and aligned with the left side of the maximum space occupied by the boiler stove.

Be sure to respect the correct installation clearances away from flammable materials and for maintenance operations.

### EXAMPLES OF HYDRAULIC INSTALLATION

**N.B.:** These diagrams are for guidance only, the correct execution is the responsibility of the plumber and the parameters must be set by the Technical Assistance Centre during first ignition (commissioning).

**These pages only include indications of possible installations and uses which must be defined together with the installer and the Technical Assistance Centre during first ignition.**

### HEATING ONLY

The combinable Kits are:

- Kit R
- Kit R2

The demand for heating can be made:

by the room temperature probe (if the read temperature falls 1°C below the set temperature).

The demand for heating is represented by a radiator on the display.

### HEATING AND INSTANT DOMESTIC HOT WATER

The combinable Kits are:

- Kit R
- Kit RW
- Kit R2

The demand for heating can be made:

by the room temperature probe (if the read temperature falls 1°C below the set temperature);

by the flow switch, following the opening of the hot water tap.

The demand for heating is represented by a radiator or by a tap on the display.

### HEATING AND BOILER FOR DOMESTIC HOT WATER

The Kits combinable with the boiler are:

- Kit R

The demand for heating can be made:

by the room temperature probe (if the read temperature falls 1°C below the set temperature);

by the boiler thermostat/probe demanding domestic hot water.

If there is a request for domestic hot water, the pump of the boiler stove turns on if the temperature of the boiler stove is 5°C above the temperature of the boiler; if this happens the three-way valve deviates to the domestic water supply. The distribution pump is off.

### COMBINATION WITH ACCUMULATOR TANK

The Kits combinable with the accumulator are:

- Kit R

The accumulation probe must be set as accumulator tank probe

The demand for heating can be made:

by the thermostat/probe of the accumulator tank.

The pump of the boiler stove ensures the heat transfer from the boiler stove to the accumulator tank.

The (secondary) booster pump provides heat transfer from the accumulator tank to the system.

The timer programming on the display applies to the (secondary) booster pump.

**TERMINAL BOARD**

On the rear (after having removed the protective cover that is fixed with two screws), there is a bracket with 2 terminal boards and 5 cable glands\*.

One terminal board (10 poles) is low voltage and the other (6 poles) is high voltage. You can find some connection examples below.

\* The cable glands are included in the bag on top of the product structure. According to the connections needed on the terminal board, break the half-part on the cover of the terminal board where the cable is to be connected and block it with the cable gland.

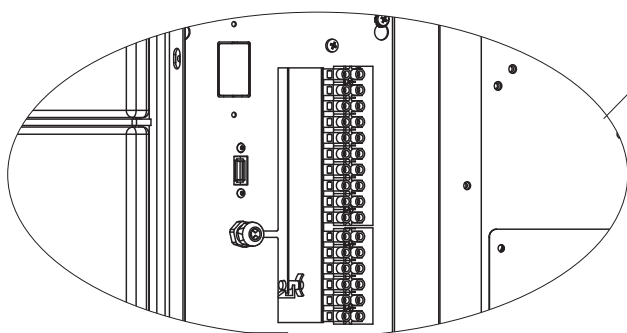
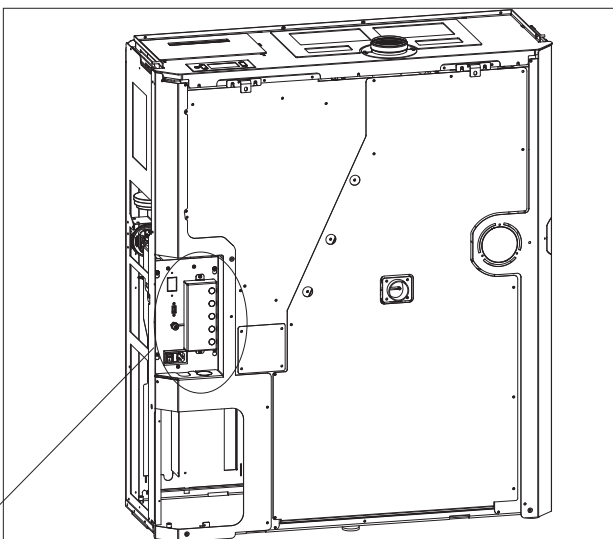

Poles are identified with a number on the product as described below

low voltage terminal board

N <sup>o</sup> POLES	POSSIBLE CONNECTIONS	NOTES
<b>1/2</b>	NTC analogue input	e.g. for a second probe for accumulator tank or boiler for domestic hot water or for an external probe for climatic curve
<b>3/4</b>	NTC probe/accumulator tank thermostat	
<b>5/6</b>	NTC probe/room thermostat	the room probe is supplied already wired as standard
<b>7/8</b>	Home Automation Input. This is an input which receives all home automation contacts	A telephone dialler, for example
<b>9/10</b>	Probe for domestic hot water boiler	

high voltage terminal board

N <sup>o</sup> POLES	POSSIBLE CONNECTIONS	NOTES
<b>1/2/3</b>	Electrical connection for booster/secondary pump (Earth, Neutral/Phase)	
<b>4/5/6</b>	EXTERNAL SOLENOID VALVE (Common, Normally Closed, Normally Open) 4 = Common 5 = Normally Closed 6 = Normally Open	During First Ignition, the technician can set up, into parameters, the connection setting on points 4 and 5, of an external boiler contact or remote alarm.

**REMARKS ON INSTALLATION**

Please note:

- installation must be carried out by authorised technical personnel;
- the appliance must be installed and operated in compliance with local and national law and European regulations. The applicable Italian regulation is UNI 10683;
- if installed in a condominium, the appliance must be approved by the administrator.

Specified below are some general instructions which, however, do not obviate the need to observe the applicable local regulations nor do they affect the installer's liability for the installation.

**Checking the suitability of the installation space**

- The room must have a volume exceeding 15 m<sup>3</sup>.
- The floor must be able to bear the weight of the product and its accessories.
- Level the product (the product is provided with adjustable feet).
- The appliance may not be installed in a bedroom, bathroom or in the same room as other equipment which draws air for combustion from the room itself, or in any area with an explosive atmosphere. Any extraction fans operating in the same room or area as the product, may affect its draught.
- In Italy, check the compatibility pursuant to UNI 10683 and UNI 7129 in the presence of gas-fired products.

**Protection from heat and safety clearances**

The surfaces of the building adjacent to the product must be protected against overheating.

The insulation to be used will depend on the type of surface in question.

The appliance must be installed in accordance with the following safety instructions:

Minimum distance from flammable materials:

- 5 cm from the rear
- 15 cm from the sides

If the material is not flammable, the minimum clearance is guaranteed by the wall-mounting brackets (pre-installed).

Do not place any flammable materials in front of the stove at less than 80 cm.

If connected to a wooden or otherwise flammable wall, the flue must be appropriately insulated.

If installed on flammable or combustible floors, or floors not able to withstand its load, place steel or glass plates beneath the stove to distribute the load.

**Information on the product's positioning**

The product is designed to operate in all climate conditions. In special circumstances, such as strong wind, the safety devices may intervene to switch the appliance off.

Contact the authorised Edilkamin Technical Assistance Centre.

### **FLUE SYSTEM(Smoke duct, flue and chimney pot)**

This chapter has been drawn up pursuant to European standards EN 13384, EN 1443, EN 1856 and EN 1457. The installer must observe both these and any other local regulations.

This manual does not in any way substitute such regulations.

The product must be connected to a flue system which ensures that the smoke produced by combustion is discharged in complete safety.

Before positioning the appliance, the installer must check that the flue is suitable.

### **SMOKE DUCT, FLUE**

The smoke duct (which connects the smoke outlet of the combustion chamber with the flue) and the flue itself must, among other regulatory requirements:

- receive the smoke from a single product (outlets from multiple appliances may not be conveyed into a single flue)
- be routed vertically for the most part
- have no downwards sloping sections
- preferably have a circular internal cross section, or with a ratio of the sides of less than 1.5
- terminate at roof level with a proper chimney pot: the flue may not discharge directly onto the wall or into an enclosed space, even if the space in question is open to the sky
- be made of material with rated fire reaction class A1 as per UNI EN 13501 or analogous national regulations
- be certified, with a chimney plate if metal
- be of uniform cross section or vary in cross section only immediately after the outlet, not at some mid point of its length

### **THE SMOKE DUCT**

Further to the general prescriptions for the smoke duct and flue, the smoke duct:

- may not be made of flexible metal material
- must be insulated, if routed through unheated areas or outdoors
- must not be routed through rooms where the installation of combustion heat generators is prohibited, where there is risk of fire, or which cannot be inspected
- must enable the recovery of soot and be open for inspection
- must have at most 3 bends with a maximum angle of 90°
- if there is a horizontal section, it must be a single one with a maximum length of no more than 3 metres, depending on the draw. Note, in any case, that long sections promote the accumulation of dirt and are harder to keep clean.



**THE FLUE:**

Further to the general prescriptions, the flue must

- only be used to discharge smoke
- be correctly sized to satisfy the requirements of smoke discharge (EN 13384-1)
- must preferably be insulated, in steel with a circular internal section. If rectangular, the corners must have a radius of not less than 20 mm, with a ratio of the internal dimensions of < 1.5
- must normally be at least 1.5 metres in vertical length
- must have a constant cross section
- must be waterproof and thermally insulated to ensure a good draw
- must preferably have a collection chamber for non-combusted matter and condensation.
- if pre-existing, it must be cleaned to prevent any fire hazard
- in general, we recommend fitting a tube inside the existing masonry chimney if its diameter is greater than 150 mm. This recommendation is purely for guidance; the installer must assess while installing, after the calculation of the draw.

**INTUBATED SYSTEM:**

Further to the general prescriptions, the intubated system must:

- operate in negative pressure
- be open to inspection
- be compliant with local regulations.

**THE CHIMNEY POT** must:

- be wind-proof
- have an internal cross section equivalent to that of the flue and a smoke outlet at least double that of the interior of the flue
- extend beyond the back flow zone (in Italy, refer to UNI 10683 point 6.5.8.)
- allow for maintenance of the chimney

For dual flues (which should be spaced at least 2 m apart), the chimney pot receiving the smoke from the solid fuel appliance or that from the higher storey, must be at least 50 cm higher than the other

**AIR INTAKE FOR COMBUSTION**

In general, we suggest two ways to ensure a proper flow of combustion air. Air must come from the outside\* It is also important to ensure a change of heating air and glass cleaning air etc.

**Indirect air intake**

The boiler stove takes air from the outside through the hole on the rear.

Install an air outlet at floor level with an effective surface area (net of the mesh or other protections) of at least 80 cm<sup>2</sup> (10 cm in diameter).

To prevent draughts, we recommend installing the intake behind the product or behind a radiator.

Installing it in front of the appliance will create unpleasant draughts.

**Direct air intake\*\***

Install an air intake of effective area (net of the mesh or other protective equipment) at least equal to that of the air intake at the back of the product.

Connect the air intake to the appliance's air intake with a tube (which may also be of the hose type). Increase the diameter of the pipe if it is not smooth: assess its pressure drops.

We recommend not exceeding a length of 3 m, considering the draw of the flue. For each curve, up to a maximum of two, the length must be reduced by 1 m. You should also consider increasing the diameter of the pipe.

\*The air may be drawn from an adjacent room only if:

- the flow is taken from permanent and unobstructed openings communicating with the outdoors
- the air pressure in the adjacent room is never lower than that of the outdoor pressure
- the adjacent room is not a garage, subject to fire hazard, a bathroom or bedroom
- the adjacent room is not a shared room in the condominium

In Italy, UNI 10683 provides that ventilation is sufficient even if a pressure difference between the outdoors and indoors of no more than 4 PA is guaranteed (UNI EN 13384-1). The installer who issues the declaration of conformity is responsible for ensuring these conditions.

\*\*The direct connection of the air intake does not make the product airtight. It is therefore necessary also to ensure recovery of the air taken in the room by the product (i.e. for the glass cleaning)

**CHECKING THE ELECTRICAL CONNECTIONS (the power socket must be located in an easily-accessible position)**

The product is supplied with an electrical power cord for connection to a 230V 50 Hz socket, preferably one equipped with a trip switch.

Variations in voltage of more than 10% can compromise its operation.

The electrical system must be compliant; check the operation of the earth in particular.

Edilkamin is not responsible for malfunctions resulting from an improperly earthed system.

The power line must be of adequate section for the power of the appliance.

The power cable must not come into contact with the flue or other hot parts of the stove.

Power up the product by setting its switch from 0 to 1.

There is one 4 A fuse on the socket with switch located at the rear of the product.

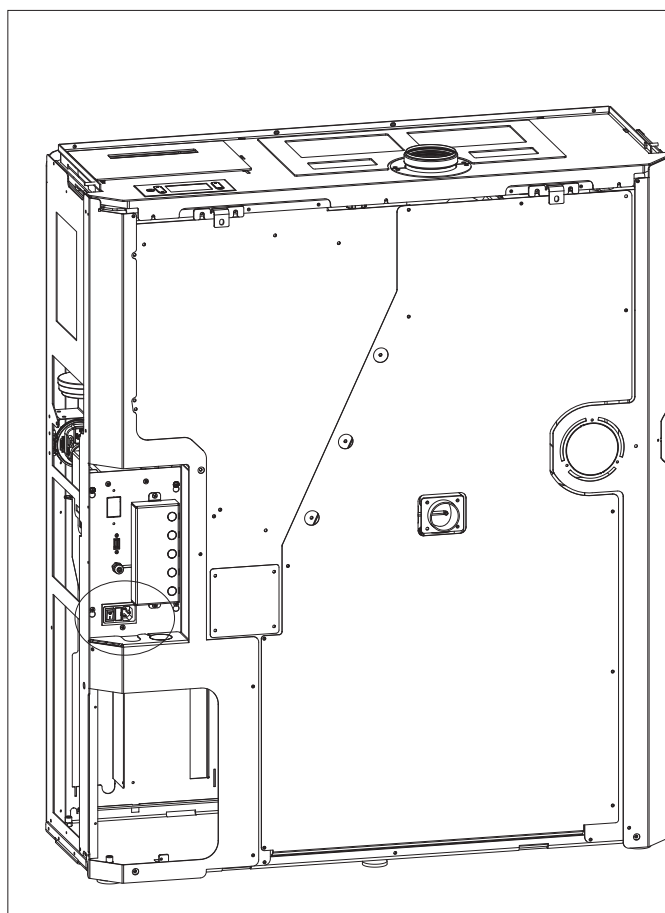
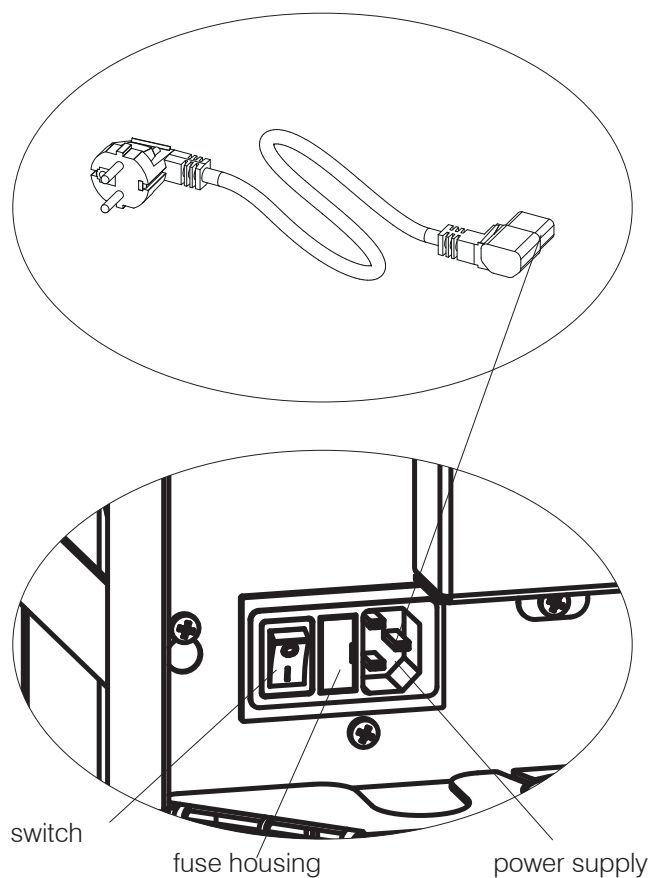

Description	Reference in the figures below	Quantity																							
Top left-hand side panel with pre-cutting for side fume discharge	(1)	1																							
Bottom left-hand side panel	(2)	1																							
Top right-hand side panel	(3)	1																							
Bottom right-hand side panel	(4)	1																							
Aesthetic top edge	(5)	Right-hand profile	(6)	1	Left-hand external profile	(7)	1	Front external profile	(8)	1	Central spacer	(9)	2	<b>Small hardware</b>			Self-tapping screw with washer 4.2x13 black	(a)	8	Countersunk hex screw M5x16	(b)	18	Self-tapping screw 4.2x9.5	(c)	9
Right-hand profile	(6)	1																							
Left-hand external profile	(7)	1																							
Front external profile	(8)	1																							
Central spacer	(9)	2																							
<b>Small hardware</b>																									
Self-tapping screw with washer 4.2x13 black	(a)	8																							
Countersunk hex screw M5x16	(b)	18																							
Self-tapping screw 4.2x9.5	(c)	9																							

“Right” and “left” refer to the product when viewed from the front.

The above-mentioned elements, once they have been mounted, will be positioned (“exploded”) as shown in the figure below. The mounting operations are described in the figures appearing on the following pages.

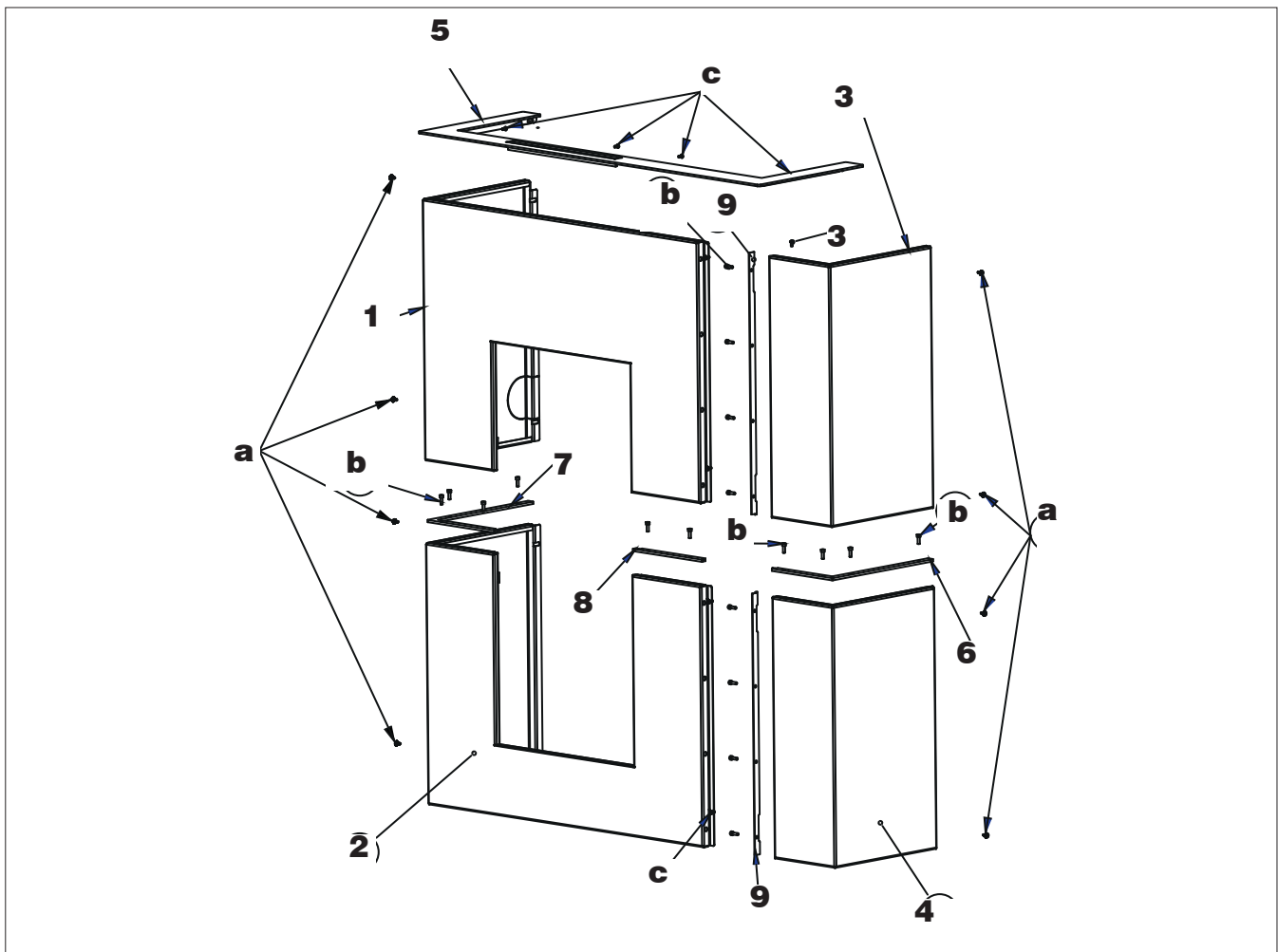



**Levelling feet**

The product is equipped with feet that can be adjusted with a screwdriver from inside the product BEFORE mounting the claddings, or by slightly raising the product.



BEFORE INSTALLING THE CLADDING, SECURE THE PRODUCT TO THE WALL WITH THE BRACKETS PROVIDED TO MAKE SURE IT DOES NOT TIP OVER.

**Assembling the left-hand side panel (1 and 2)**

Screw on the bottom left-hand side panel, the external left-hand profile and the left-hand front profile. Slot in the top left-hand side panel (the screws are used to attach the top side panel) to obtain the complete left-hand side panel

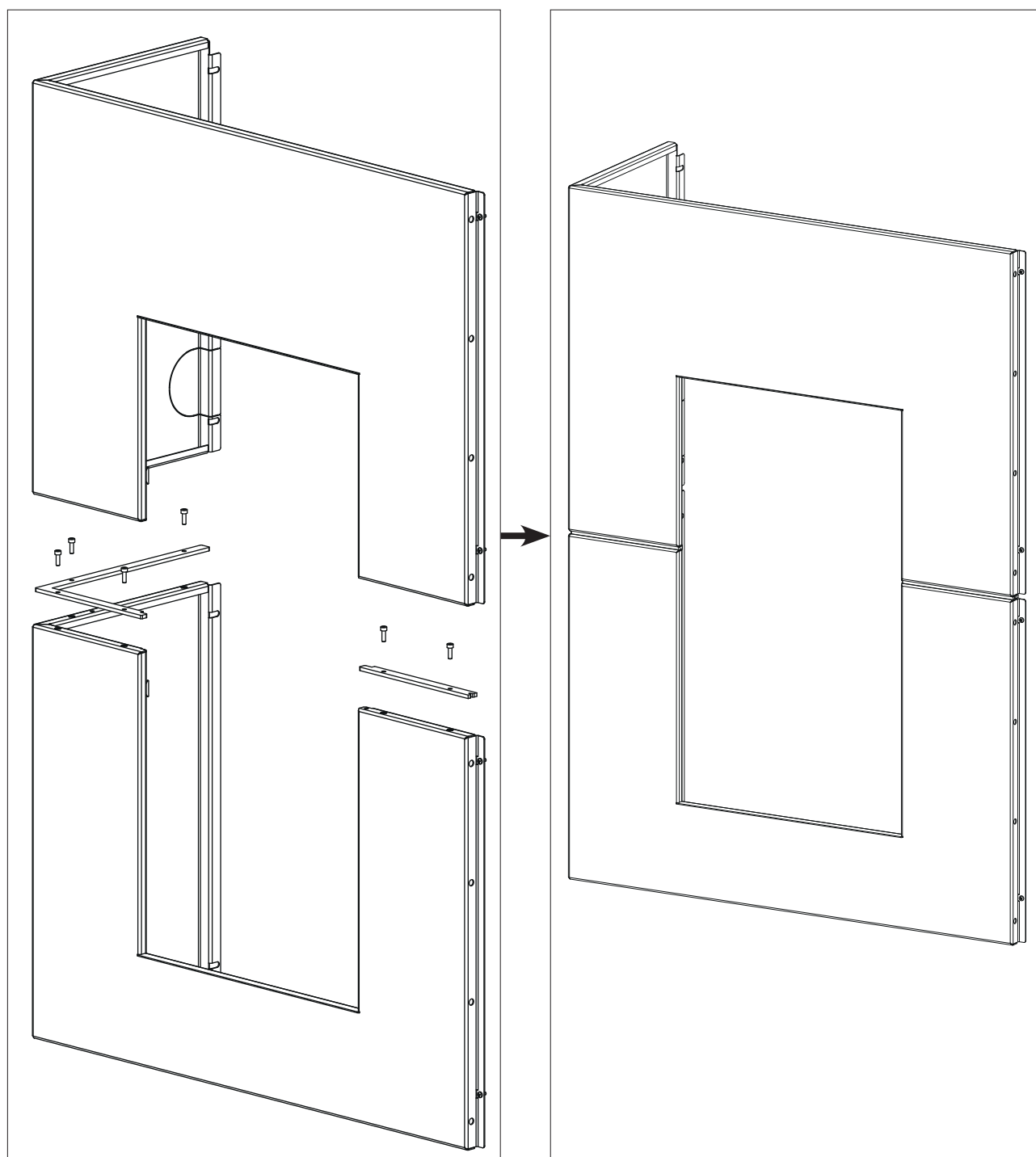

**Fitting of the assembled left-hand side panel**

Slot the left-hand side panel into the two top front "recesses" and rest it on the bottom.

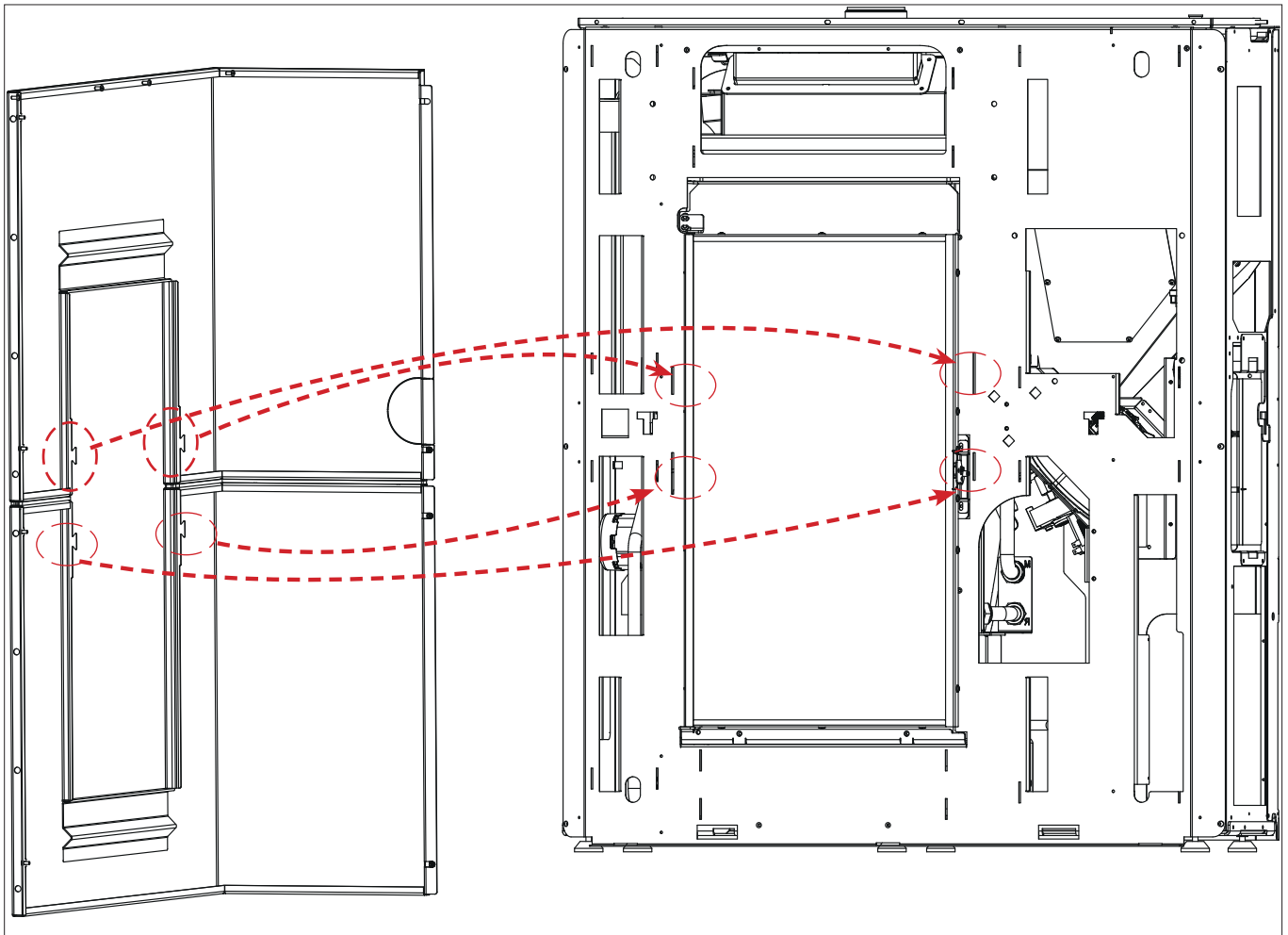

Screw it on the structure on the left-hand side (3 screws) and front (4 screws).

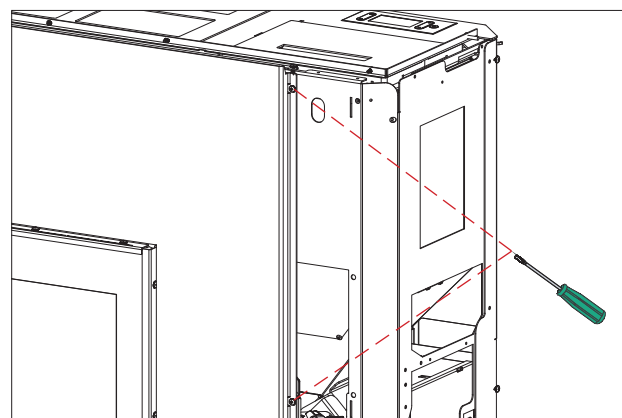
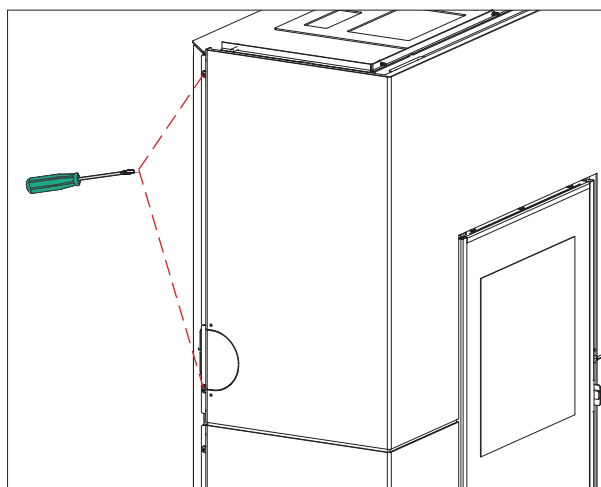

**Assembling the right-hand side panel (3 and 4)**

Screw on the top right-hand side panel, the external right-hand profile and the right-hand front profile. Slot the top right-hand side panel. Screw on the central spacers until obtaining the complete right-hand side panel.

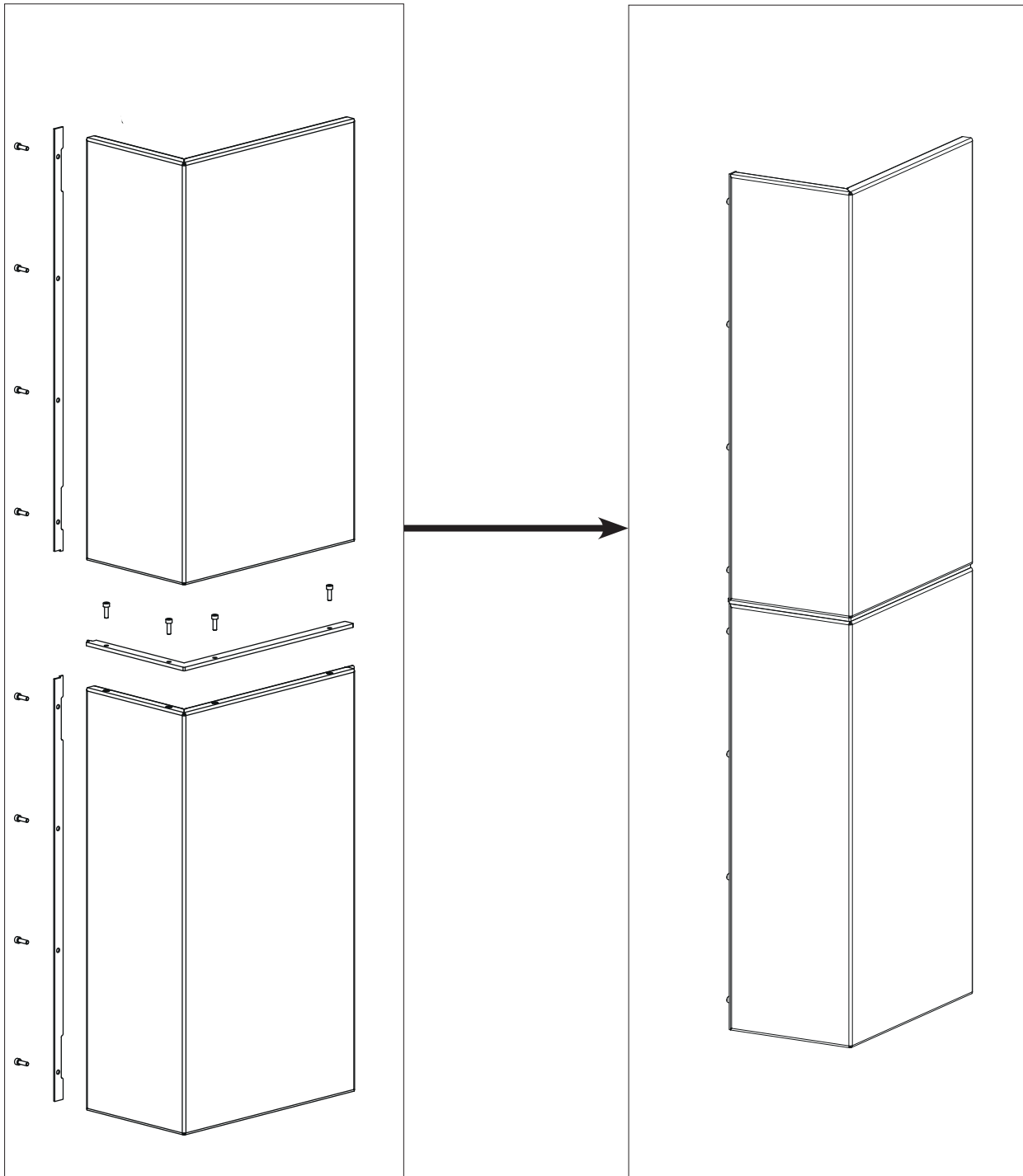

Insert the assembled right-hand side panel.  
Fasten it to the top and right-hand sides with a screw.

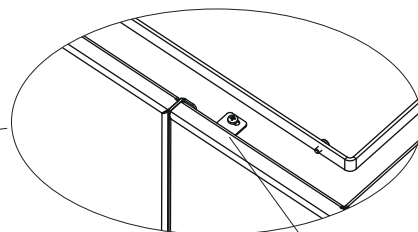
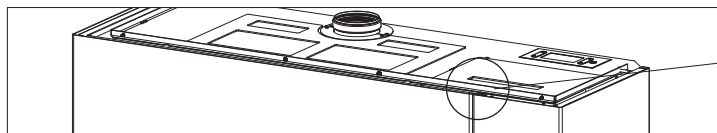
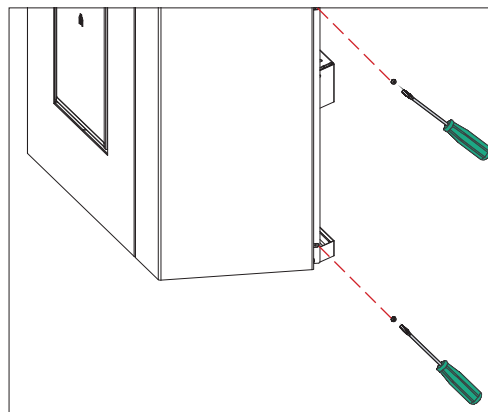
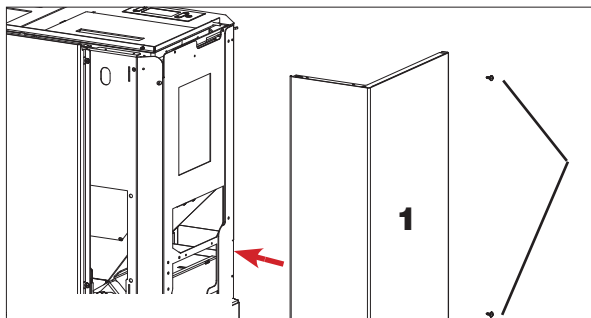

screw on top



**Mounting the aesthetic top edge**

Place the aesthetic top edge by slotting it into the two pins to the right and left and fastening it with the 4 screws on the front.

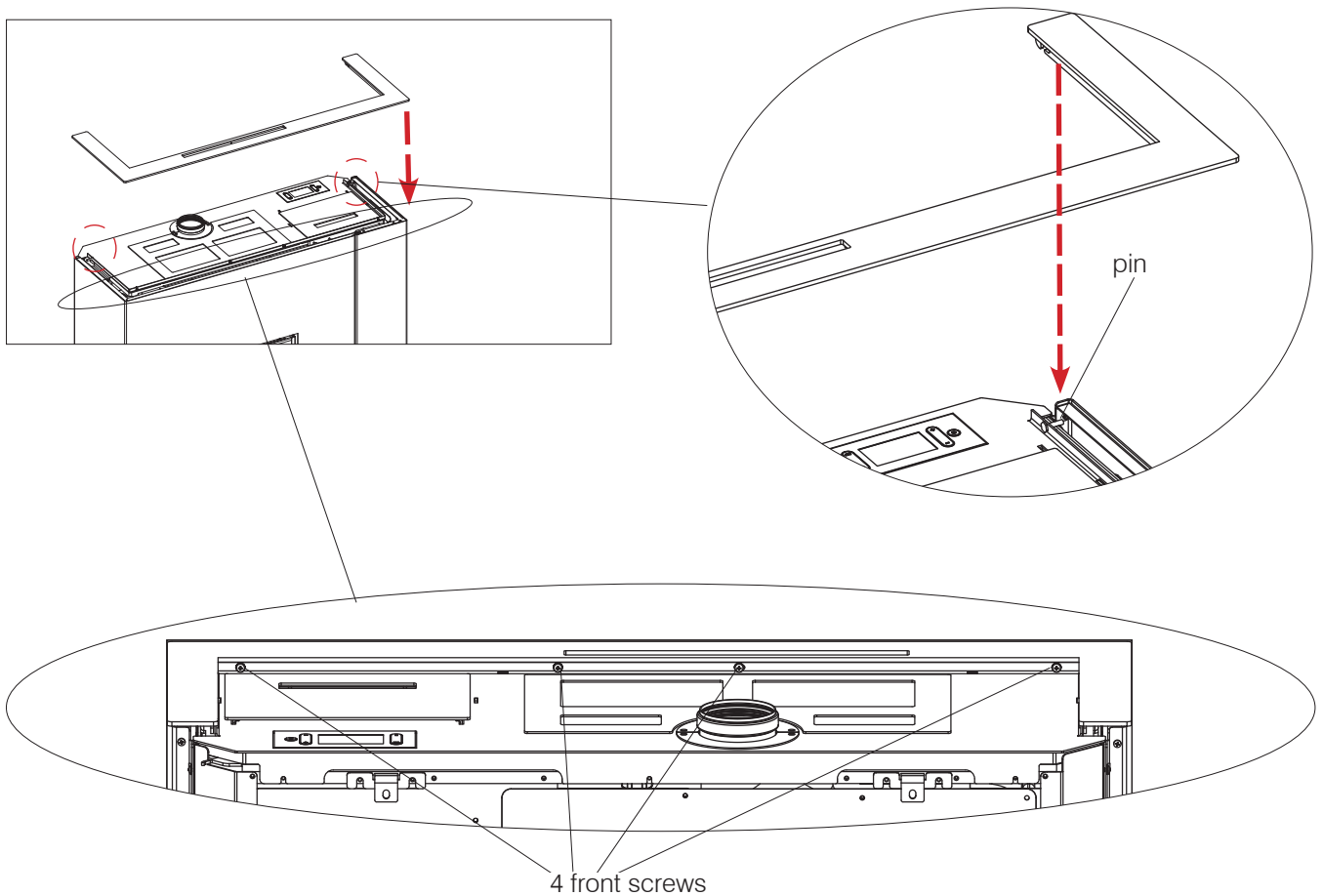

**The mounted cladding product appears as shown below.**

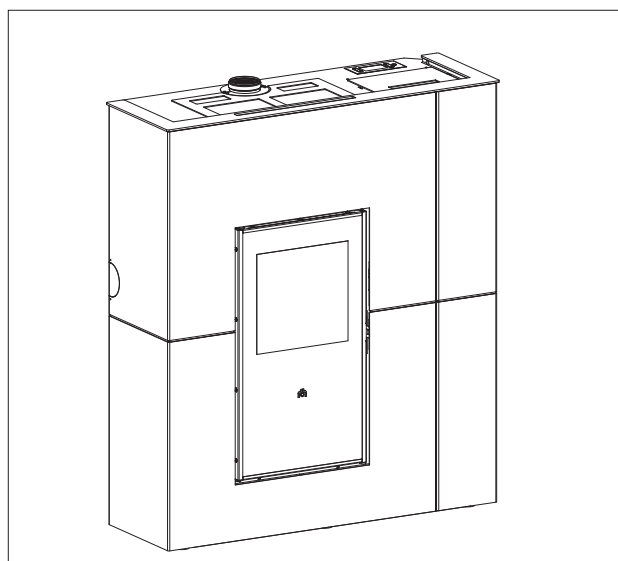

The Blade H ceramic cladding is divided as shown below:

- a box with the metal parts (A), indicated in the table below (3-4-5-6);
- two boxes (B)-(C) strapped together each containing a ceramic side panel.

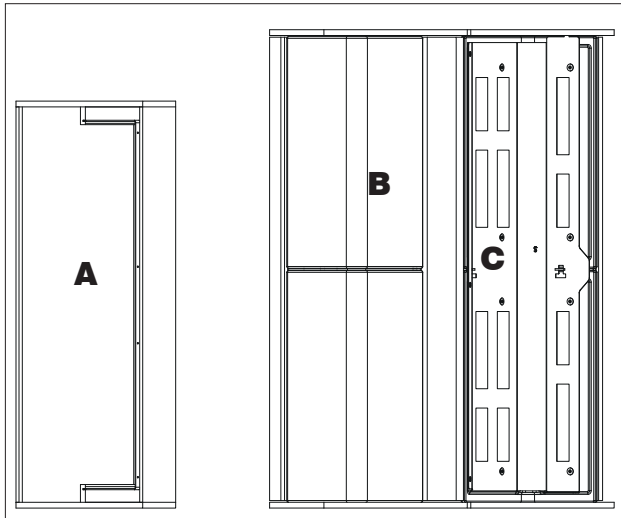

The position of each ceramic side panel is engraved on the inside of the panel (S = left; D = right)

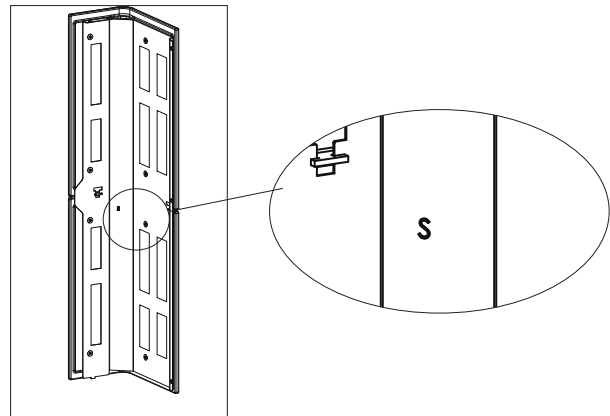

Description	Reference in the figures below	Quantity
Right-hand ceramic side panel	(1)	1
Left-hand side panel	(2)	1
Steel top front panel	(3)	1
Steel bottom front panel	(4)	1
Aesthetic top edge	(5)	1
Filler profile between the top and bottom front panels made of steel	(6)	1
Small hardware		

“Right” and “left” refer to the product when viewed from the front.

The above-mentioned elements, once they have been mounted, will be positioned as shown in the adjacent figure.

The mounting operations are described in the figures appearing on the following pages.

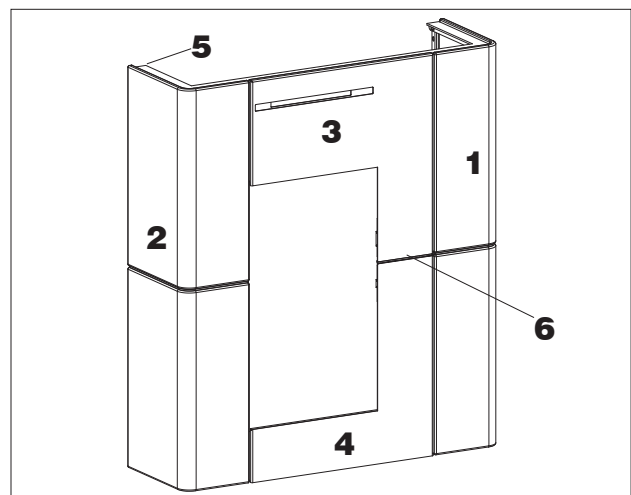

**Levelling feet**

The product is equipped with feet that can be adjusted with a screwdriver from inside the product BEFORE mounting the claddings.



BEFORE INSTALLING THE CLADDING, SECURE THE PRODUCT TO THE WALL WITH THE BRACKETS PROVIDED TO MAKE SURE IT DOES NOT TIP OVER.

**Before mounting the cladding, for the ceramic version, orient the deflector with the hot air outlet towards the FRONT. This can be done by loosening the four fastening screws and turning it.**

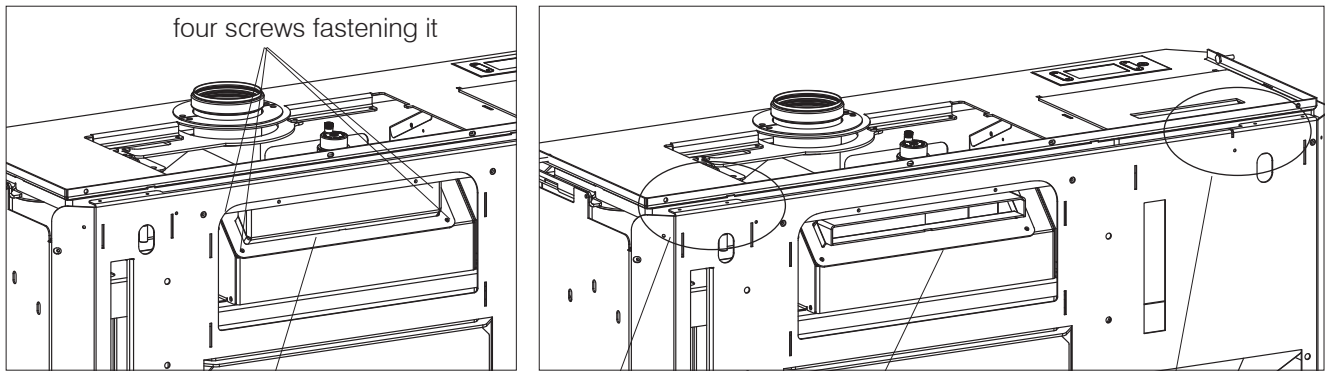

four screws fastening it

hot air outlet

hot air outlet oriented towards the FRONT

Insert the grub screws provided. They will be necessary for adjustment operations.

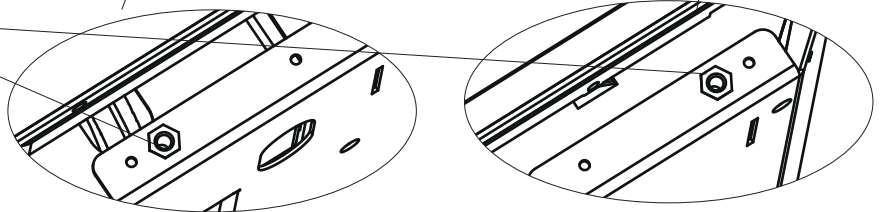

**Fitting the steel bottom front panel (3)**

Insert the bottom front panel and screw it on

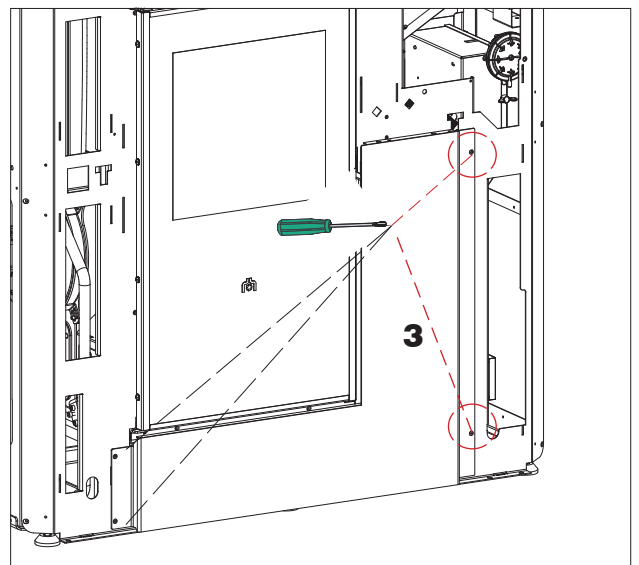
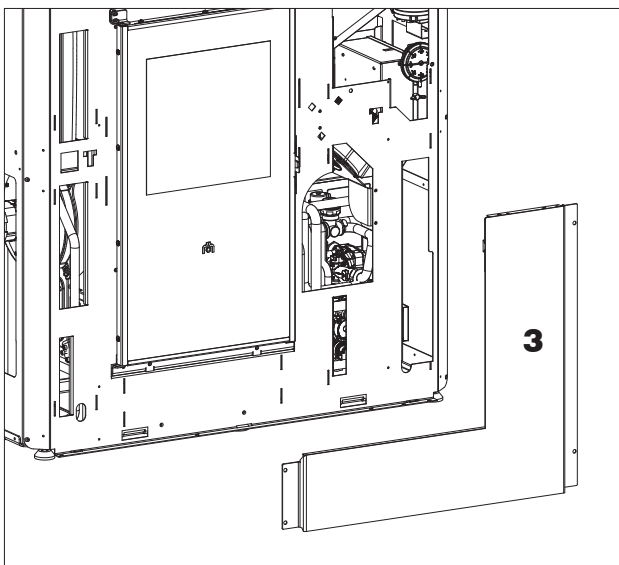

**Fitting the filler profile between the top and bottom front panels made of steel (6)**

Insert the profile by slotting in the pins

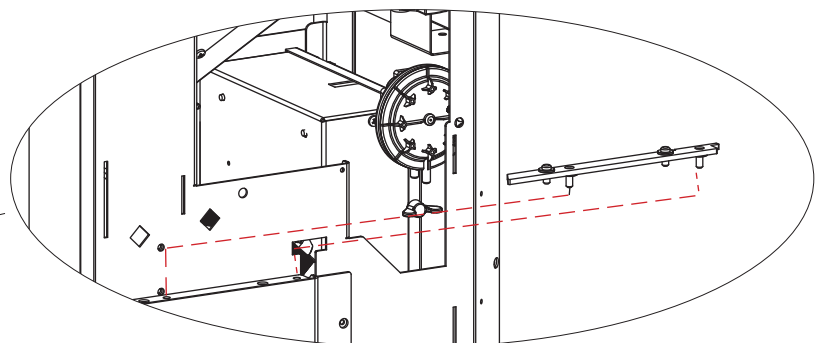
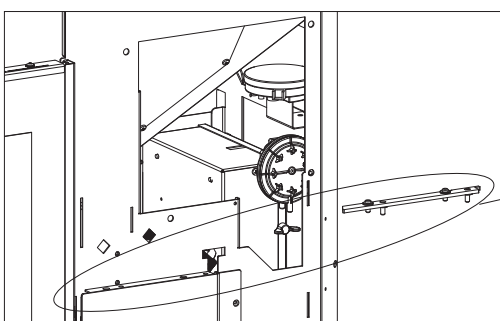

**Fitting the steel top front panel (4)**

Insert the top front panel and screw it on

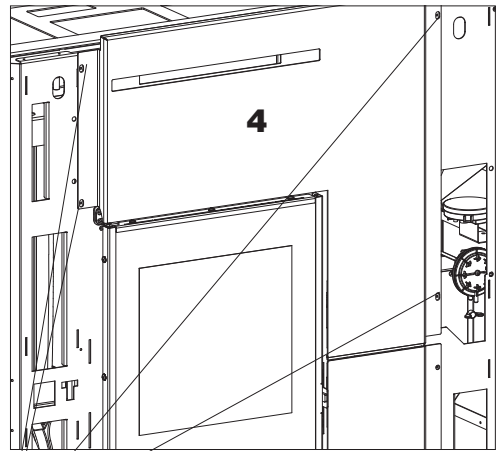
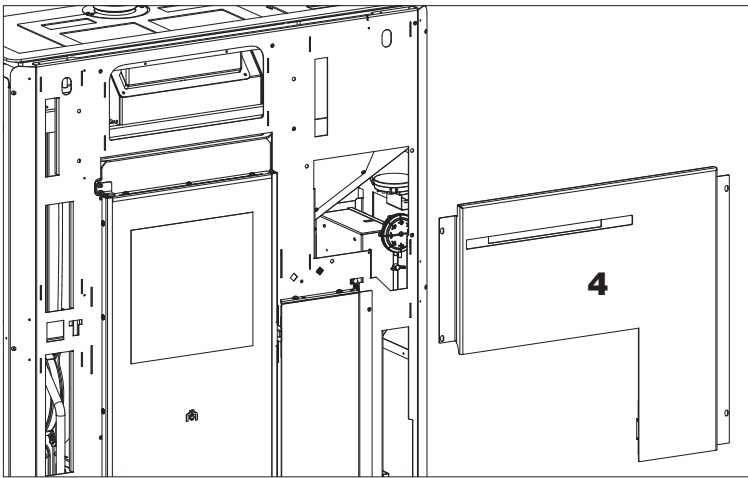

screws

**Fitting the ceramic side panels (1)-(2)**

Slot in a side panel towards the bottom.

Fasten it with two screws on the top then with three screws on the side. Repeat the operation for the other side panel.

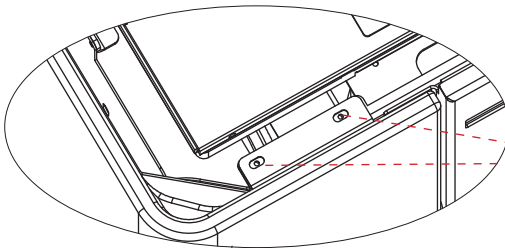

two top screws

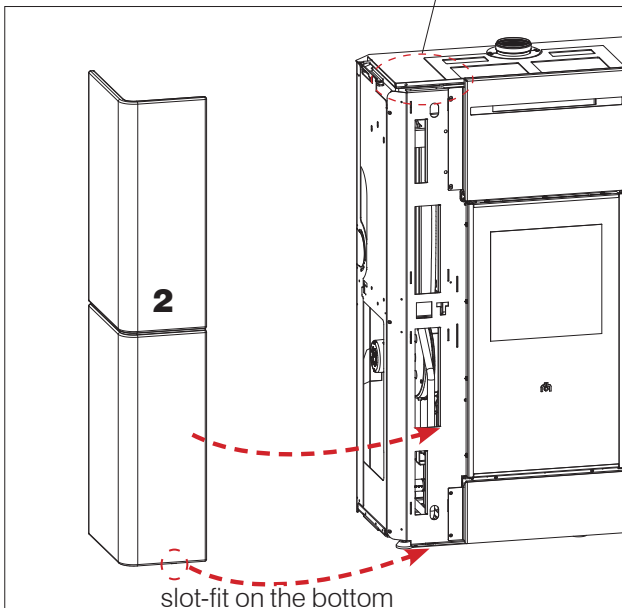

slot-fit on the bottom

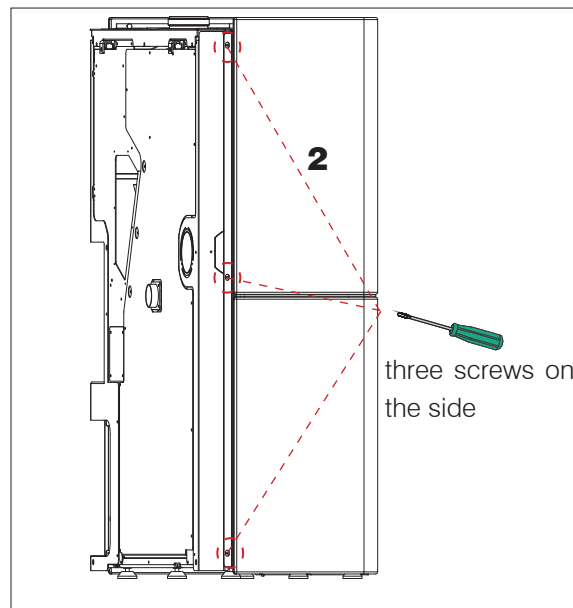

three screws on the side

**Possible adjustments for improved alignment**

To perform any necessary adjustments it is necessary to intervene:

1. on the upper slots where the ceramic elements are screws on;
2. on the side slots where the ceramic elements are screwed on;
3. on the front slots where the top steel front panel is screwed on (the bottom one cannot be adjusted)
4. Any necessary adjustments can be made by intervening on the grub screws inserted near the upper slots. Adjust the height of the side panel by tightening/loosening the grub screws with the Allen key provided.

1 upper slots where the ceramic elements are screws on

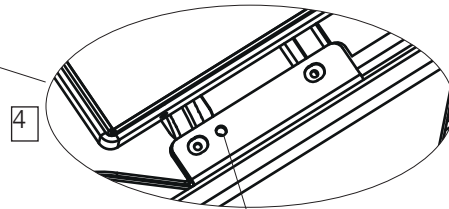
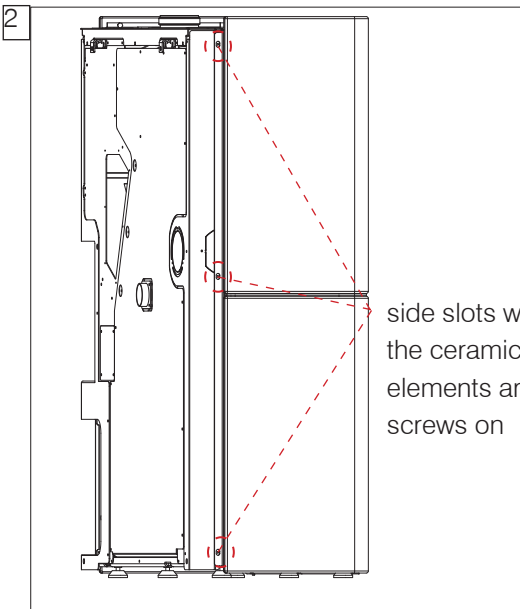
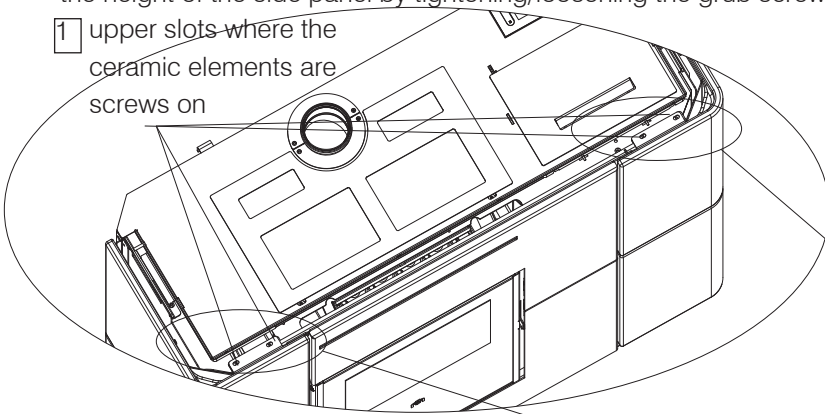

Any necessary adjustments can be made by intervening on the grub screws inserted near the upper slots. Adjust the height of the side panel by tightening/loosening the grub screws with the Allen key provided.

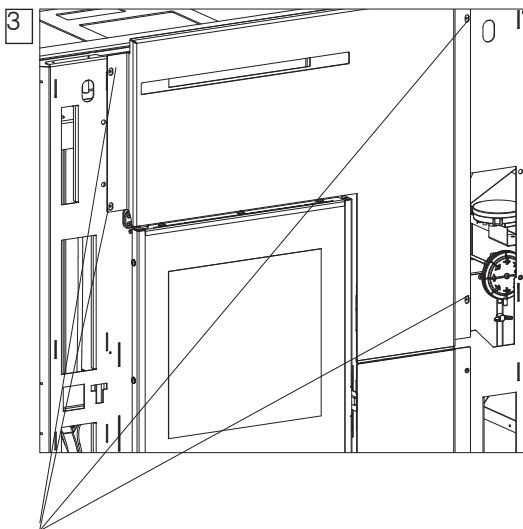

front slots where the upper steel front panel is screwed on

**Mounting the aesthetic top edge (5)**

Place the aesthetic top edge by slotting it into the two pins to the right and left and fastening it with the screws on the front.

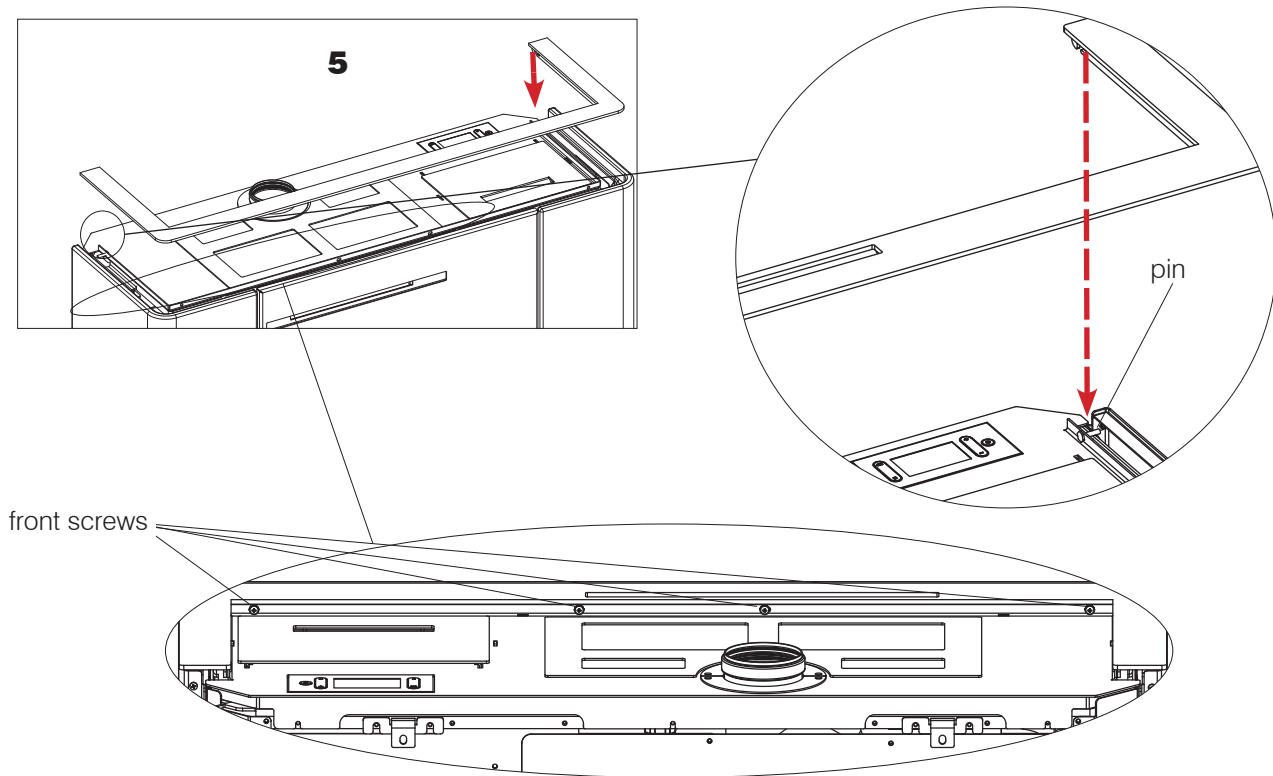

**The product with the cladding mounted appears as shown in the adjacent picture.**



**FIRST IGNITION (COMMISSIONING) PHASES**

- Make sure you have read and understood this manual.
- Remove all flammable materials from the appliance (manuals, labels, etc.). In particular remove any labels from the glass.
- Make sure the technician has carried out first ignition for the product, and also filled the pellet reservoir for the first time. Refer to the “Various Menus” chapter under the “Pellet loading” paragraph.



When ignited the first few times, there may be a slight smell of paint which will disappear in a short time.

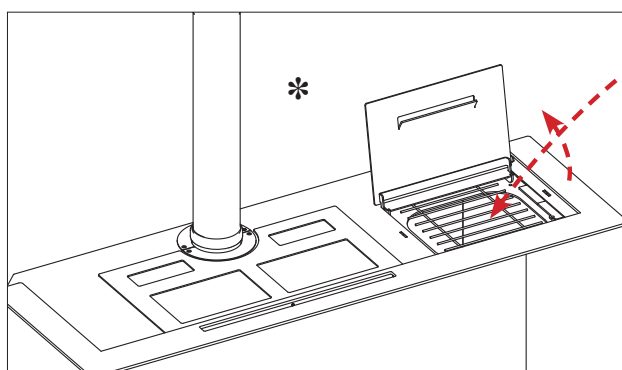

**LOADING THE PELLETS INTO THE TANK.**

To access the tank, open the lid.



When the boiler stove is hot, DO NOT MAKE CONTACT between the pellet bag and the top grille. Use the glove provided when loading the stove while it operates and is therefore hot to the touch. Take care not to touch the fume exhaust pipe when hot.

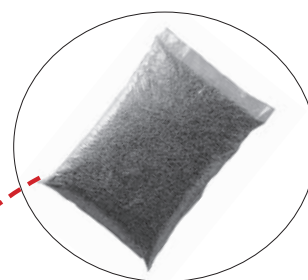

**FUEL**

Use Class A1 wood pellets conforming to the UNI EN ISO 17225-2 standard or similar local regulations envisaging, for example, products with the following characteristics:  
 diameter 6 mm  
 length 3–4 cm  
 humidity < 10%

For reasons of safety and environmental compatibility, DO NOT burn, among other, plastic, painted wood, coal or bark.

Do not use the stove as an incinerator.



Caution  
 Using fuels other than those specified can damage the appliance.



**VENT**

During normal operations the vent is automatic. During installation, the technician must check the efficiency of the automatic vent (located beneath the upper grille) and assess whether a manual vent needs to be installed.

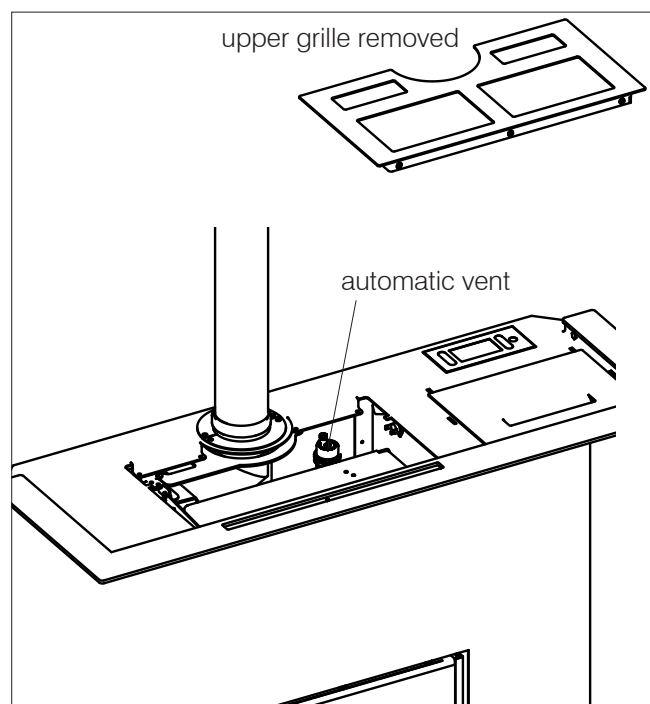

**INTERFACE** The only interface is the display on the top of the stove

The views display the functions and are described in the following sections.

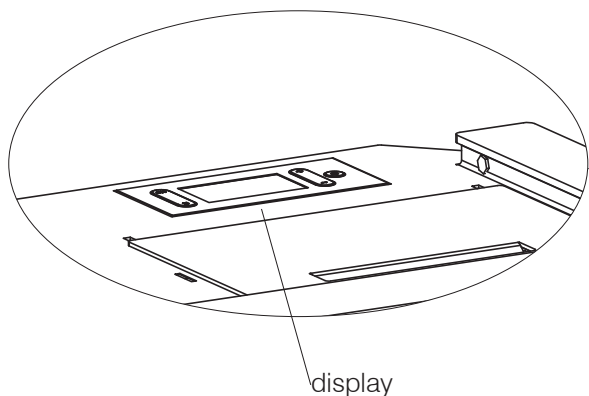

display

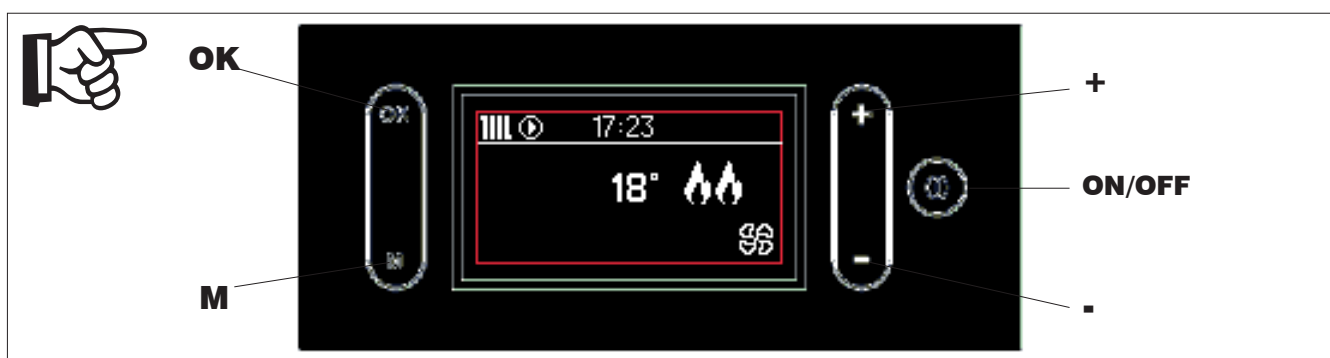
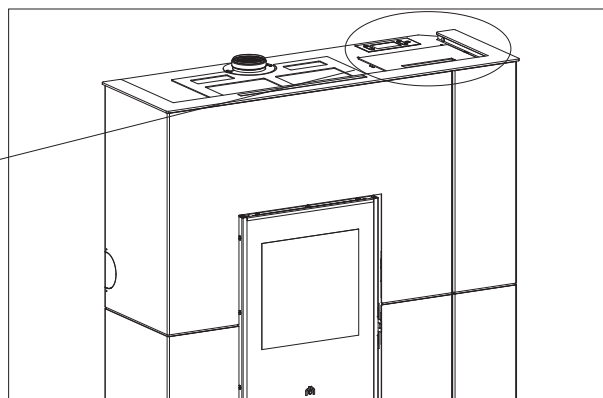

**BUTTONS**

The display has 5 buttons:

**ON/OFF** to switch from the OFF mode to the ON mode. In the menu, it can be used to confirm and return to the main screen.

**+/-** to increase/decrease the set values or scroll between the Menu options.

**M**: to access the Menu or exit the Menu options.

**OK** to confirm an operation (2 seconds) or to access a Menu option.

**Display power saving**

The back-lighting goes off after 1 minute if the display is not used. The display switches off after 3 minutes if it is not used. Press any button to activate it again.

**If at the first switch-on operation** the language is not set, the adjacent language selection screen will appear. Choose the language with the +/- buttons and confirm with OK.

You are now asked to confirm or set the Time and Date.

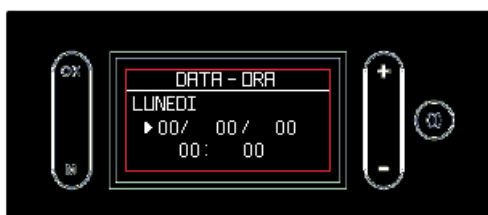

After confirming the setting, the display will show the next field.



Set the values with the +/- keys and confirm with OK. The day of the week is calculated automatically using a perpetual calendar.

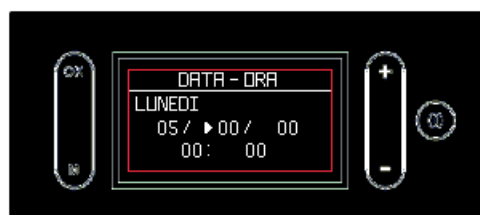



**THE READING AREA OF THE DISPLAY** is

divided in two parts:

- **the status bar**, above the horizontal line;
- **main area**, under the horizontal line.

The views display the functions and are described in the following sections



**The status bar** contains:

- the symbols of the heat request (radiator, tap, pump activation);
- the current time

Example of domestic hot water request

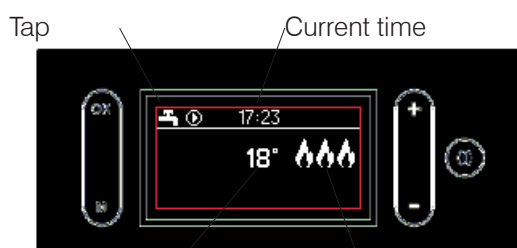

**The main area** contains:

- the room temperature\*
- the operating power of the product (from 1 upwards), which is represented by the flame symbols
- the fan speed, which is represented by the filled blades symbol (if absent, the fan is off).

\* The product is programmed by default with a delta of +/- 1 °C to optimise comfort.

The technician can change this setting during commissioning to suit the needs of the application.

The display shows the temperature rounded down. This means that 20.1°C and 20.9°C are indicated as "20".

E.g., with the room temperature set to 20° C, the product will enter modulation mode/switch off when a temperature of 21° C is reached and will switch on again below 19° C.

Power indication

Room temperature

If you are using a room thermostat instead of the room probe provided as standard, the display will appear as below. The heat demand is indicated by the radiator symbol.



**SIMPLIFIED USE after first ignition**

In default mode, with the product connected to the power supply, press the ON/OFF button on the display to "activate" the boiler stove and adjust the desired room temperature with the +/- buttons. The boiler stove will switch on and off and will adjust its power automatically to keep the set temperature.

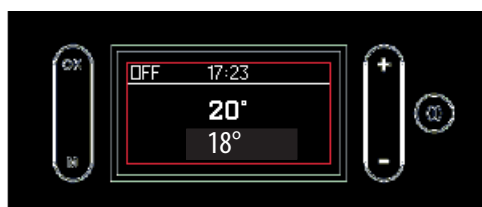

By pressing the "M" button you access the Menu screen

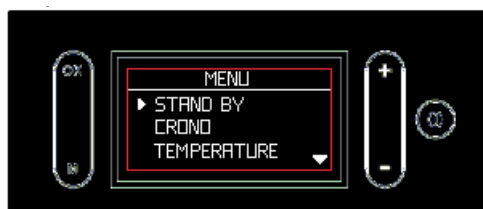

the product operates with the **POSSIBLE MODES** (described below):

- **OFF MODE**
- **ON MODE**
- **STAND BY MODE**
- **ALARM MODE**

**OFF MODE**

The product is “disabled” and does not produce heat. The product may turn on only for the anti-freeze function (described on this page). You can set the product to the OFF mode by pressing the ON/OFF button on the display. Also an external contact (crono, phone dialler) may switch the boiler stove to the OFF mode.

Pressing the +/- keys has no effect. Pressing the M key displays the Menus.

The display shows the current time, room temperature and the status in relation to which the product is OFF.

The product can be in the OFF mode in these cases:

- due to manual operation of the user (with probe)

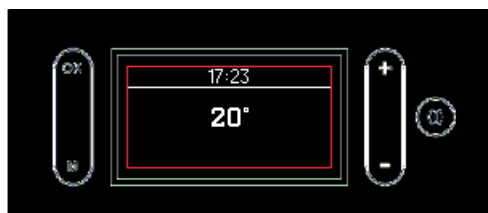

- due to manual operation of the user (with thermostat)

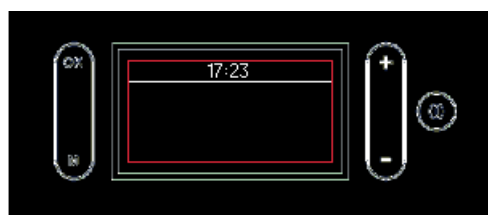

- due to crono



- due to Black Out

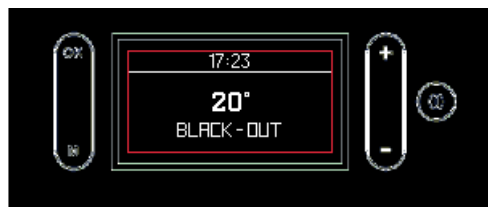

**ANTI-FREEZE (selectable from the Menu only by the Technical Assistance Centre during commissioning)**

Can only be activated from OFF and STAND-BY modes.

The function preserves only the heating circuit, not the domestic hot water circuit.

The anti-freeze has two levels:

- level 1: pump on
- level 2: pump and boiler stove on; it is activated by the anti-freeze mode “level 1” if the probe temperature reads a temperature which is below the Anti-freeze Setpoint.

The activation of the anti-freeze (both level 1 and level 2) is indicated by the symbol “frost” on the display.



From the OFF screen, press and hold the ON/OFF button to go to the ON screen.

**ON MODE**

The product is “active” and can produce heat. The product can be on/in ignition.

The display shows

- the current time
- the current room temperature (top number in the main area)
- the set room temperature (bottom number in the main area)
- the power level (represented by the flames)
- the fan level (represented by the filling in of the blades)

If the timer programming is active (Crono), the text “TIMER” appears on the right.

The figure below shows the various possibilities.

On without heating demands (Stand By Off)



On with thermostat Off (Stand by Off)



On with Timer (Stand by Off)

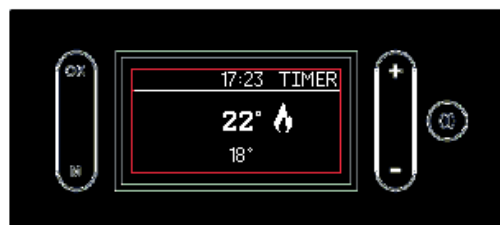

On with heating demand



On with thermostat demand



On with Timer



On with domestic hot water demand



**ON MODE with STAND BY**

In ON mode with STAND BY (the product is “active” but with stand by function enabled) the product turns on only with heating demand. If the Stand By function is active, the display shows the same information as in the ON state without flame (on the top left you will see “STB”).

The LCD shows the following information:

- product mode (STB)
- the current time
- the room temperature (or the mode of the room thermostat)
- the activation of the timer programming if present (Timer/Crono)

The figure below shows the various possible screens on the display

STAND BY



STAND BY WITH THERMOSTAT



STAND BY WITH TIMER



While in stand-by mode, and ON, the product turns on only if there is a heat request.

If the product was operating, it switches to minimum power and waits for the set time before going off.

If the product was in the ignition phase, it completes the ignition phase and switches to minimum power and waits for the set time before going off.

If the product was OFF and is switched to ON, the stove goes immediately to stand-by without ignition.

**ALARM MODE**

In case of Shutdown due to alarm, the display shows the type of alarm. See the paragraph “Troubleshooting”

From the display, you can:

- **Switch from OFF to ON modes, by pressing and holding the ON/OFF button**
- **Set the desired room temperature with the +/- buttons (see below)**



Switching on and off will take a few minutes, during which the flame must appear or go off. Just wait without taking any action. During ignition, the display shows the text "START". During switch-off, the display shows the text "OFF".

In default mode, with the product connected to the power supply, press the ON/OFF button on the display to "activate" the boiler stove and adjust the desired room temperature with the +/- buttons. The boiler stove will switch on and off and will adjust its power automatically to keep the set temperature.

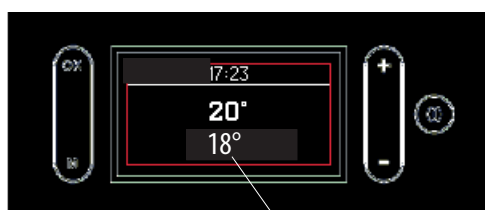

desired room temperature

By pressing the "M" button you access the Menu screen

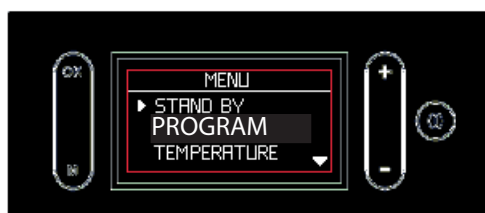

Accessing the **Menus**, you can set the following (described on the following pages)

- **Stand By**
- **Crono (PROGRAM)**
- **Temperature**
- **Ventilation (AIR VENTILATION)**
- **Pellet Load- SCREW LOAD** (shown only when the product is OFF)
- **Language**
- **Beep**
- **Date / time**
- **Info** (technician only)
- **Pressure**
- **Technical menu** (technician only)

## Menu

Press the “M” button to display the menu.

When the menu displays, the buttons have the following functions:

“+” : scroll up

“-” : scroll down

press and release “OK”: enter menu option

press and release “M”: quit menu option

Press the ON/OFF button to confirm and return to the main screen.



## Stand by (figures on the side)

When the Stand by function is active, the product shuts off when the temperature setpoint is reached and turns on again when the room temperature drops.

When the Stand By function is not active, the product sets itself to minimum power when the temperature setpoint is reached.

To access the function from the main menu (as indicated in the Menu section above), press the M button. Scroll using the +/- buttons and select the function by pressing the “OK” button.

Use the “+/-” buttons to select OFF or ON.

To exit without saving, press the “M” button.

If you selected ON, the display shows the minutes for which the product will continue running at minimum power even when the temperature setpoint has been reached.

Use the “+/-” buttons to increase or decrease this time in minutes.

Confirm by pressing the “OK” button for two seconds.

The display will return to the previous menu level.

Press ON/OFF to quit without saving

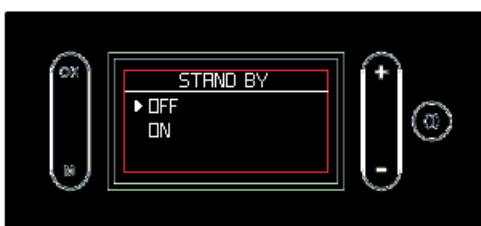

**Crono - PROGRAM**(figures on the side)

When the Crono function is active, the user sets a temperature setpoint and a time zone for which that setpoint is specified.

The setting takes different steps, which can also be not consecutive:

- activate/deactivate Crono mode
- setting of three different temperature levels (T1 must always be lower than T2 and T2 than T3)
- choose if you want to apply the same timer in Crono mode, 7 days a week, 5 days a week, weekend only or different day by day and match one of the three temperatures to the time period

You can also display the time periods and the set temperatures (“DISPLAY” selectable with the “OK” button from the Crono function).

The ON/OFF button allows you to always return to the main screen.

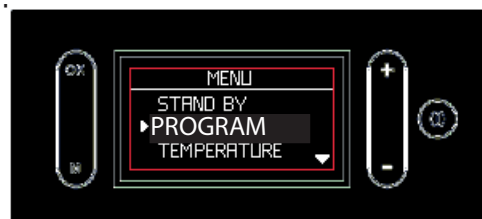
**Activation/deactivation of the Crono function, “ACTIVE” on the display** - (figure below)

To access the Crono function from the main menu, press the M button. Scroll using the +/- buttons and select the function by pressing “OK”. To select “ACTIVATE” press “OK”.

Use the “+/-” buttons to select On/Off, i.e. activate/deactivate the function.

To exit without saving, press the “M” button.

Confirm by pressing the “OK” button for two seconds. If the Crono function is active, the text “Timer” will appear on the right.

**Setting the temperature levels “TEMP” on the display** (figures on the side)

To enter the setting (“TEMP” on the display) press the “OK” button.

The Crono has three adjustable setpoints: T1, T2, T3.

You access the temperature by pressing OK.

You can change the temperature with “+/-”. Press OK to confirm.

Press “+/-” to shift between levels.

T1 must always be lower than T2 and T2 than T3: if you try to set a T1 temperature that is greater than T2, T1 temperature will automatically match T2.

Confirm by pressing the “OK” button for 2 seconds.

NOTE when the arrow is on the temperature, you can move from one T to the next using +/- . When the arrow is on a number (e.g. 16), you can increase/decrease using +/- .

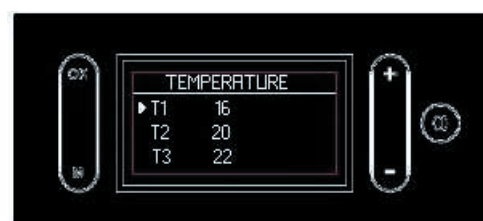

**Setting of the time periods, “SET” on the display** (figure on the side)

From Crono, press the “OK” button to enter the “SET” function.

The first screen allows you to choose whether to apply the time periods for 7/7 days, 5/7, weekend only or day by day.

The second screen (accessible by pressing the “OK” button from the first screen) allows you to choose the temperature level between T1, T2 and T3.

Press OK to set the start and end of the time period to which you wish to apply the chosen temperature level. This is done in steps of 30’.

The buttons have the following functions:

“+/-”: move **the cursor** indicating the time forwards/backwards. Hold the button down to scroll through the times more quickly.

“OK”: confirm time and increase the temperature level or OFF

“M”: return to the previous Menu

ON/OFF: return to the main screen.

The ignition times are indicated by the white square. In zones with white squares, the appliance is ON.

Once the time zones have been set, press “OK” for two seconds to confirm.

You return to the previous screen.

The settings will not be saved otherwise.

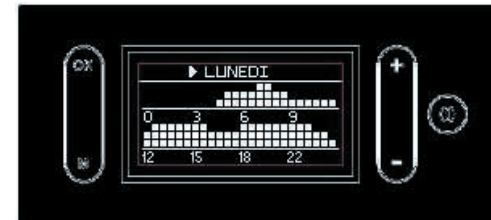
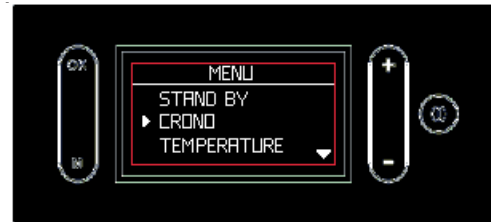

time can be set with the “+/-” buttons

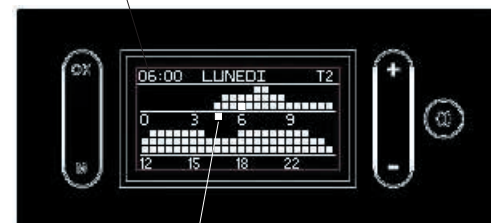

**cursor**



**Display the Crono function, “SHOW”** (figures on the side)

From Crono, press the “OK” button to enter the “DISPLAY” function.

The buttons have the following functions:

“+”: to scroll through the days ahead

“-”: to scroll through the days back

“OK”: return to the previous menu

“M”: return to the previous menu

ON/OFF: return to the main screen.

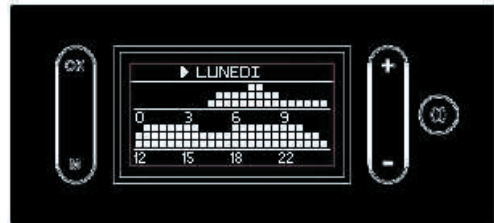
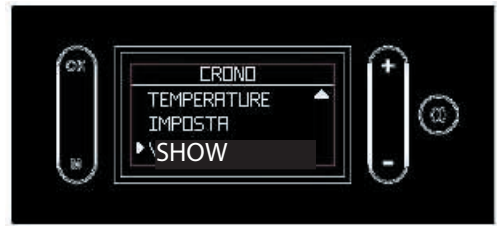

**Setting the water Temperature (“TEMPERATURE” on the display)**

Allows you to set the boiler temperature and the accumulator temperature. If the external probe is active, it allows you to set the climatic curve instead of the boiler temperature.

To access the function from the main menu (as indicated in the Menu section above), press the M button. Scroll using the +/- buttons and select the function by pressing the “OK” button.

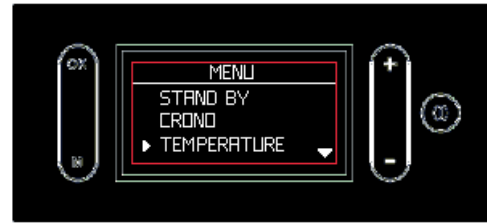

Choose the option with the “+/-” buttons, press “OK” to change the setting

You can set the water temperature in the boiler stove (BOILER on the display)

current water temperature in the boiler stove  
desired water temperature

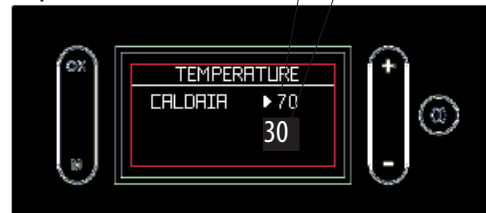

In presence of external probe, the water temperature is automatically calculated according to the outside temperature. You can set the curve as shown in the figure at the side (CURVE on the display)



In presence of accumulator tank, you can set its temperature as shown in the figure at the side (PUFFER on the display)

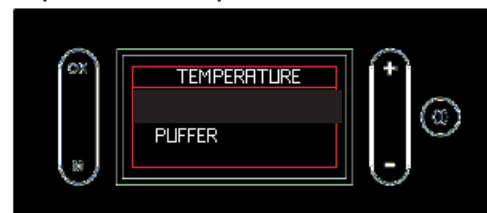

The domestic hot water boiler is set as shown at the side (BOILER on the side of the display)



**Fan setting (“VENTILATION” on the display)**

To access the function from the main menu (as indicated in the Menu section above), press the M button. Scroll using the +/- buttons and select the function by pressing the “OK” button.

Allows you to set the ventilation:

- manually, by setting a speed from 1 upwards
- in automatic mode (“AUTO”): the boiler stove varies ventilation according to the power
- in OFF mode: the ventilation is off

Choose the option with the “+/-” buttons, press “OK” to change the setting



**Load Pellets - SCREW LOAD**

Allows you to load pellets after the worm screw has emptied following a no-pellets alarm.

Used by the technician during commissioning.

Available only in the OFF state. If you attempt to activate the function in other states, access is not granted.

To access the function from the main menu (as indicated in the Menu section above), press the M button. Scroll using the +/- buttons and select the function by pressing OK.

Use the “+/-” buttons to activate/deactivate the function.

Press “M” to quit without saving.

Confirm by pressing the “OK” button for 2 seconds.



**Language**

Selects the language.

This appears the first time the display is electrically activated or by entering the menu.

To access the function from the main menu (as indicated in the Menu section above), press the M button. Scroll using the +/- buttons and select the function by pressing OK.

Use the “+/-” buttons to select the language.

To exit without saving, press the “M” button.

Confirm by pressing the “OK” button for two seconds.



**Beep**

Allows you to enable/disable the beep.  
 To access the function from the main menu (as indicated in the Menu section above), press the M button. Scroll using the +/- buttons and select the function by pressing OK.  
 Use the "+/-" buttons to select On/Off.  
 Press "M" to quit without saving.  
 Confirm by pressing the "OK" button for 2 seconds.

**Date/Time**

Sets the current date/time.  
 This appears the first time the display is electrically activated or by entering the menu.  
 To access the function from the main menu (as indicated in the Menu section above), press the M button. Scroll using the +/- buttons and select the function by pressing OK.  
 Use the "+/-" buttons.  
 Press "M" to quit without saving.  
 Confirm by pressing the "OK" button for 2 seconds.



**Info**

These readings should only be done when requested by the technician.  
 The technician understands the diagnostic meaning of the messages and numbers, and may ask you to read them if you experience problems.



**Pressure**

Allows you to activate/deactivate the visualisation of pressure on the display.

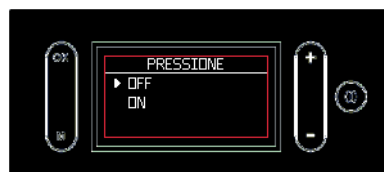

**Technical menu**

Accessible only to an authorised technician with the appropriate password.

**Disconnect the product from the power supply.  
Failure to service the product properly will prevent it from working properly.  
Any problems due to failure in servicing the stove will void the warranty.**

**DAILY MAINTENANCE**

These operations must be done with the product off, cold and preferably disconnected from the mains.

A suitable vacuum cleaner is required.

The entire procedure takes just a few minutes.

Operations are represented in the figures whose numbers correspond to the instructions on this page.

Do not dump the cleaning residue into the pellet tank. Once it is refitted, make sure that the ash tray is properly placed in its housing, to avoid glass breakage when closing.

Make sure that the grate is properly placed in its housing after maintenance operations, if not, the stove may have ignition problems.



**Using the stove without cleaning the grate can cause the gas in the combustion chamber to ignite and detonate.**

**DAILY MAINTENANCE**

1. Raise the aesthetic grille (if it is hot, use the glove) and activate the cleaning brush beneath the pellet loading cover.
2. Open the combustion chamber door (P) using the removable handle.
3. Empty the ash tray (B) and grate (C) into a non-flammable container (the ashes may still contain embers and/or hot parts) or vacuum if cold. Vacuum out the interior of the combustion chamber, the bed, and the compartment around the grate into which the ash falls.
4. Scrape the grate with the provided scraper and clean out any obstructed holes.
5. If necessary, clean the glass when cold using a dedicated product (e.g. Glasskamin), which your dealer should have.

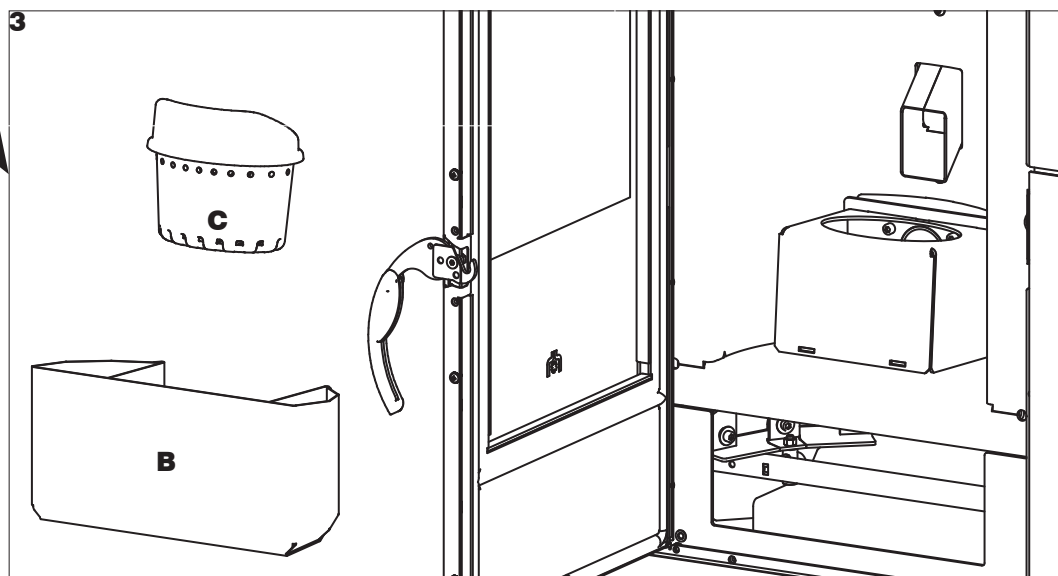
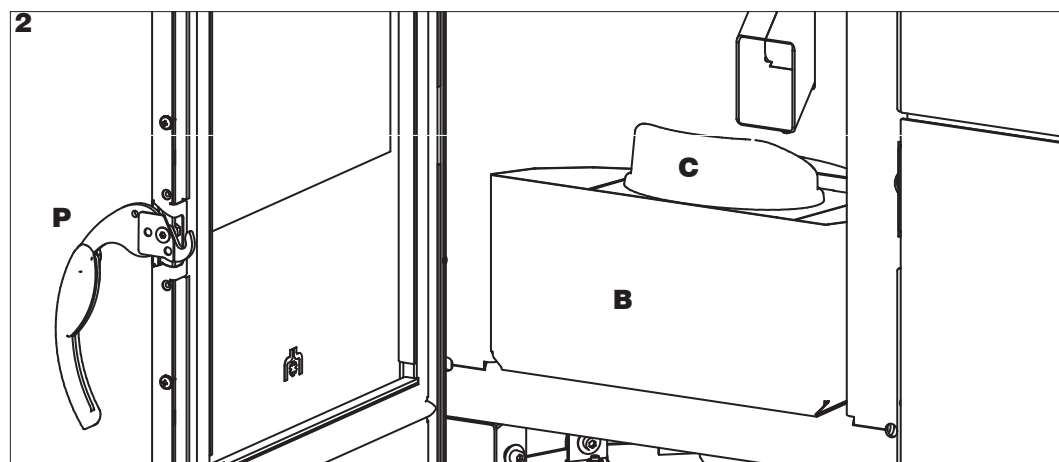
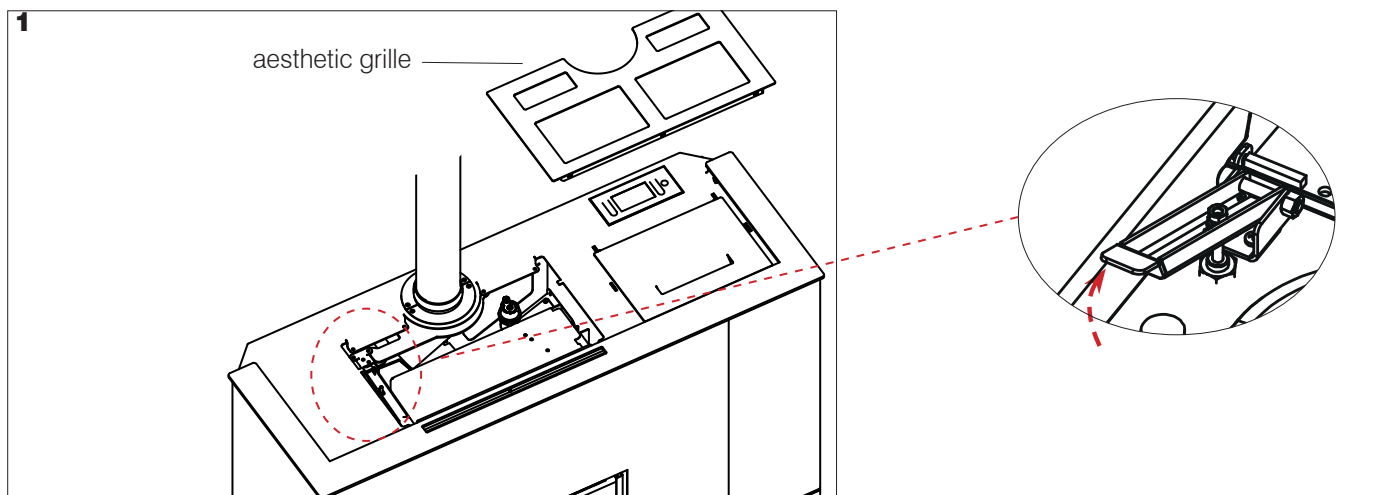

ENGLISH

**WEEKLY MAINTENANCE**

When the product is off and cold, after having activated the cleaning brush as in routine maintenance, you should vacuum the inspection plate under the combustion chamber (\*)

To do so, remove the deflector (D) which is only resting on it.

Put back the deflector after cleaning.

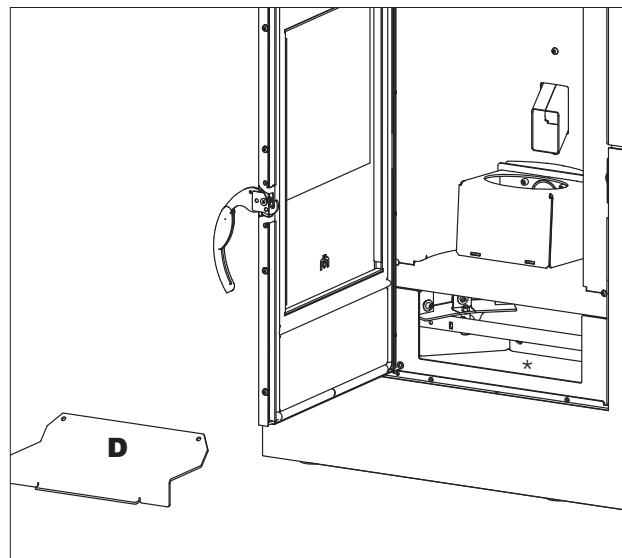
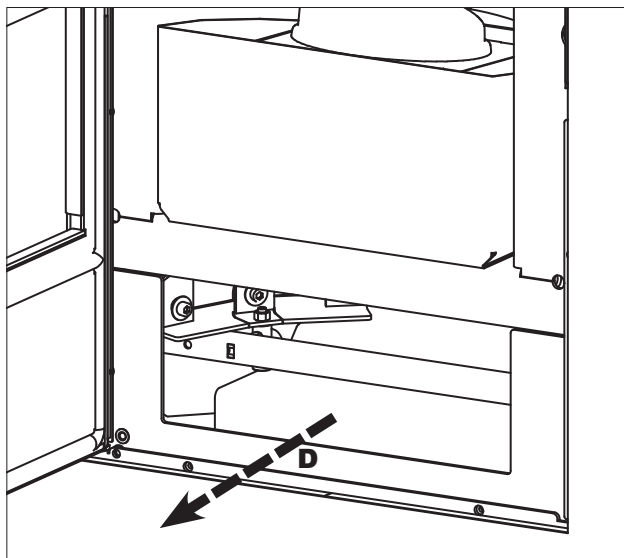

**SEASONAL MAINTENANCE**

**(to be carried out by the technical assistance centre)**

This consists of cleaning the stove inside and out.

**If the product is used intensively, we recommend cleaning the smoke flue every 3 months.**

You should clean the chimney system at least once a year (check local regulations for details).

If you fail to regularly clean and inspect the system, there is an increased risk of the chimney pot catching fire.

We recommend against using compressed air to clean the combustion air inlet.

**SUMMER SHUTDOWN**

During the period of disuse, keep the stoves doors, hatches and lids closed. We recommend emptying out the pellet tank. Place the package of dessicating salts inside the combustion chamber.

**SPARE PARTS**

for any spare parts, contact your retailer or technician. Using non-original spare parts may damage the appliance and relieves Edilkamin of all liability for damage that may arise from doing this. Do not make unauthorised modifications.

**DISPOSAL**

At the end of its service life, dispose of the product as required by regulations.



In accordance with art. 26 of Legislative Decree no. 49 of 14th March 2014, "Implementation of Directive 2012/19/UE on the disposal of electrical and electronic devices (RAEE)".

The crossed-out dustbin symbol displayed on equipment or its packaging indicates that the product at the end of its life must be collected separately from other waste.

At the end of its useful life, the user should therefore deliver the product to a suitable local sorted collection centre for electrical and electronic devices.

Sorted collection for recycling, treatment and environmentally compatible scrapping contributes to the prevention of negative effects on the environment and health, and promotes the re-use and recycling of the materials of which the equipment is made.

If problems occur, the product shuts itself off automatically.  
The display will show the reason (see below).



**Do not disconnect from the power supply.**

**To start the product up again, allow the shut-down procedure to complete, then press the ON/OFF button.**

**Before starting the product up again, check the reason for the shutdown and CLEAN THE GRATE.**

**The product is equipped with a safety valve but, if the grate is not cleaned regularly as explained above, ignition may involve a small detonation. If white smoke forms in the combustion chamber for a long time, disconnect the mains supply and wait 30 minutes before opening the door and emptying out the grate.**

#### SHUTDOWN MESSAGES AND THEIR SOLUTIONS:

MESSAGE	PROBLEM	SOLUTION
<b>H01</b>	displays when the combustion air intake is below the set level	<ul style="list-style-type: none"> <li>• Check that the combustion chamber door is closed</li> <li>• Check the regular maintenance of the stove</li> <li>• Check that smoke discharge and combustion air ducts are clean.</li> </ul>
<b>H02</b>	displays when the logic board does not detect the correct smoke fan speed	<ul style="list-style-type: none"> <li>• Contact the technician</li> </ul>
<b>H03</b>	displays when the thermocouple detects a smoke temperature lower than the set value and interprets this as the absence of flame	<ul style="list-style-type: none"> <li>• Check that there are pellets in the tank</li> <li>• Check if the water temperature has increased due to the closing of a valve (contact the technician)</li> <li>• Contact the technician</li> </ul>
<b>H04</b>	displays when ignition times out unsuccessfully	<p>There are two possibilities:</p> <p>NO flame:</p> <ul style="list-style-type: none"> <li>• Check that the grate is seated properly and is clean</li> <li>• Check that there are pellets in the tank and grate</li> <li>• Use a piece of solid paraffin to light the stove (contact the technician first)</li> </ul> <p>Flame present:</p> <ul style="list-style-type: none"> <li>• Contact the technician</li> </ul>
<b>H05</b>	Shut down due to air flow rate sensor breakage	<ul style="list-style-type: none"> <li>• Contact the technician</li> </ul>
<b>H06</b>	displays when the logic board determines that the smoke temperature probe is broken or disconnected	<ul style="list-style-type: none"> <li>• Contact the technician</li> </ul>



MESSAGE	PROBLEM	SOLUTION
<b>H07</b>	Shut-down due to exceeding maximum smoke temperature	<ul style="list-style-type: none"> <li>• Check the type of pellet (contact the technician if in doubt)</li> <li>• contact the technician</li> </ul>
<b>H08</b>	Switching OFF due to excessive overheating of the product	<ul style="list-style-type: none"> <li>• see H07</li> </ul>
<b>H09</b>	Shut down due to gear motor breakage or seizure	<ul style="list-style-type: none"> <li>• Contact the technician</li> </ul>
<b>H10</b>	Switching OFF due to circuit board overheating	<ul style="list-style-type: none"> <li>• Contact the technician</li> </ul>
<b>H11</b>	Switching OFF due to the intervention of the safety pressure switch	<ul style="list-style-type: none"> <li>• Ensure the stove and flue are clean</li> <li>• Contact the technician</li> </ul>
<b>H12</b>	Room temperature probe failure.	<ul style="list-style-type: none"> <li>• Contact the technician</li> </ul>
<b>H13</b>	Shut-down due to breakage of the reading water temperature probe of the boiler stove	<ul style="list-style-type: none"> <li>• Contact the technician</li> </ul>
<b>H14</b>	Shut-down due to breakage of the water temperature probe in the boiler	<ul style="list-style-type: none"> <li>• Contact the technician</li> </ul>
<b>H15</b>	Shut-down due to exceeding maximum water temperature in the boiler stove	<ul style="list-style-type: none"> <li>• Contact the technician</li> </ul>
<b>H16</b>	Shut-down due to breakage of the pressure switch for reading water pressure of the boiler stove	<ul style="list-style-type: none"> <li>• Contact the technician</li> </ul>
<b>H17</b>	Shut down due to breakage of external probe	<ul style="list-style-type: none"> <li>• Contact the technician</li> </ul>
<b>H18</b>	Shut-down due to breakage of the water temperature probe in the accumulator tank	<ul style="list-style-type: none"> <li>• Contact the technician</li> </ul>

**WATER OVERHEATING (SHUT-DOWN WITHOUT ALARM)**

If the water in the boiler stove reaches a temperature of 85°C, the boiling stove shuts down without switching to alarm mode. The text STBY appears on the display next to the room temperature.

The product is working, but it must be serviced by an authorised Edilkamin technician.

**MAINTENANCE (SIGNAL THAT DOES NOT CAUSE SHUT-DOWN)**

A wrench symbol is shown on the display after 2000 hours of operation.

The product is working, but it must be serviced by an authorised Edilkamin technician.







**EDILKAMIN**

TECNOLOGIA DEL FUOCO

[www.edilkamin.com](http://www.edilkamin.com)