

HAAS  
+  
SOHN

## HSP 6 Helena 465.32 RLU

**Equipment sheet**  
Pellet stove

**GB**

# Notes in the text



Of utmost importance there are the notes entitled **WARNING**. The notes entitled **WARNING** advise you on **serious danger of damage to the heating device or of an injury**.



The note entitled **Notice** advises you on possible damage to your heating device.



The note entitled **Important** calls your attention to the information important for the operation of your heating device.



The note itself calls your attention to the information important for the operation of your heating device in general.

# Contents

<b>1. Technical data</b> .....	1
<b>2. Dimensions</b> .....	2
2.1. HSP 6 Helena 465.32 RLU .....	2
2.2. HSP 6 Helena 465.32-C RLU .....	2
<b>3. Cleaning work</b> .....	3
3.1. Cleaning the surface .....	3
3.2. Cleaning the glass panel .....	3
3.3. Clean combustion chamber "function instruction" Error F040 .....	3
3.4. Cleaning the combustion pot - weekly .....	3
<b>4. Maintenance work</b> .....	5
4.1. Cleaning the flue gas passes .....	5
4.2. Cleaning the pellet container - annual maintenance .....	9
<b>5. Replacement parts list</b> .....	10
5.1. Replacement parts list HSP 6 Helena 465.32 RLU (without trim parts) .....	10
5.2. Detail A1 .....	12
5.3. Replacement parts list HSP 6 Helena 465.32 RLU .....	13
5.4. Replacement parts list HSP 6 Helena 465.32-C RLU .....	14
<b>6. Circuit diagram</b> .....	16



# 1. Technical data

	<b>HSP 6 Helena 465.32 RLU</b>	<b>HSP 6 Helena 465.32-C RLU</b>
Heat output range:	2,4 – 8,3 kW	2,4 – 8,3 kW
Nominal heat output:	8,0 kW	8,0 kW
Height:	1201 mm	1201 mm
Width:	550 mm	560 mm
Depth:	500 mm	513 mm
Weight:	118 kg	164 kg
Diameter of flue elbow:	80 mm	80 mm
Flue gas temperature:	206 °C	206 °C
Testing transport pressure at nominal output:	11 Pa	11 Pa
Testing transport pressure at partial output:	5 Pa	5 Pa
Flue gas flow rate in g/s	5,6 g/s	5,6 g/s
CO level in flue gas (%) (min./max.)	0,001/0,023 %	0,001/0,023 %
Efficiency:	90/95 %	90/95 %
CO level in flue gas:	<15 mg/Nm <sup>3</sup>	<15 mg/Nm <sup>3</sup>
NOx level in flue gas:	143 mg/Nm <sup>3</sup>	143 mg/Nm <sup>3</sup>
OGC level in flue gas:	<5 mg/Nm <sup>3</sup>	<5 mg/Nm <sup>3</sup>
Proportion of dust in flue gas:	9 mg/Nm <sup>3</sup>	9 mg/Nm <sup>3</sup>
Contents of storage container (pellet tank):	about 17 kg	about 32 kg
Duration of burn with one charge (min./max.):	about 10 h/30 h	about 20 h/60 h
Permitted fuel: Low-dust wood pellets	diameter: 6 mm	diameter: 6 mm
to Ö-Norm M 7135, DIN plus, EN plus-A1	length: max. 30 mm	length: max. 30 mm
Room heating capacity to Ö-Norm M 7521:	max. 230 m <sup>3</sup>	max. 230 m <sup>3</sup>
Room heating capacity to DIN 18893, constant heating:	250m <sup>3</sup> /145m <sup>3</sup> /98m <sup>3</sup>	250m <sup>3</sup> /145m <sup>3</sup> /98m <sup>3</sup>
Room heating capacity to DIN 18893, timed heating:	165m <sup>3</sup> /95m <sup>3</sup> /65m <sup>3</sup>	165m <sup>3</sup> /95m <sup>3</sup> /65m <sup>3</sup>
Electricity supply:	230 V (50 Hz)	230 V (50 Hz)
Electricity supply input:		
in normal operation:	max. 50 W	max. 50 W
Electric ignition (for max. 15 minutes on ignition):	max. 380 W	max. 380 W
Electronics fuses: (F3)	T 0,315 A, 250 V	T 0,315 A, 250 V
Fuses for the ignition, screw conveyor motor, induced draught, (F1)	T 3,15 A, 250 V	T 3,15 A, 250 V

## Safety distances

Minimal distances from flammable materials:	side:	15 cm
	rear:	10 cm
	front (radiation area):	80 cm

# 2. Dimensions

## 2.1. HSP 6 Helena 465.32 RLU

Dimensions

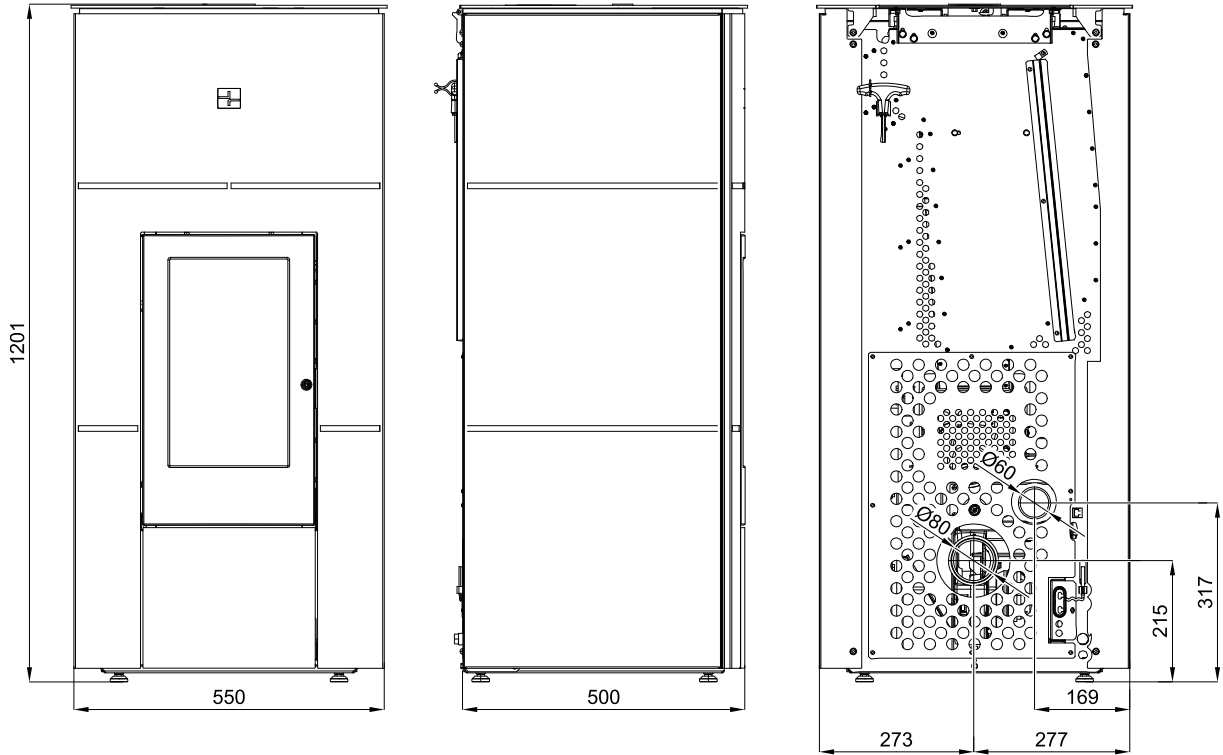

## 2.2. HSP 6 Helena 465.32-C RLU

GB

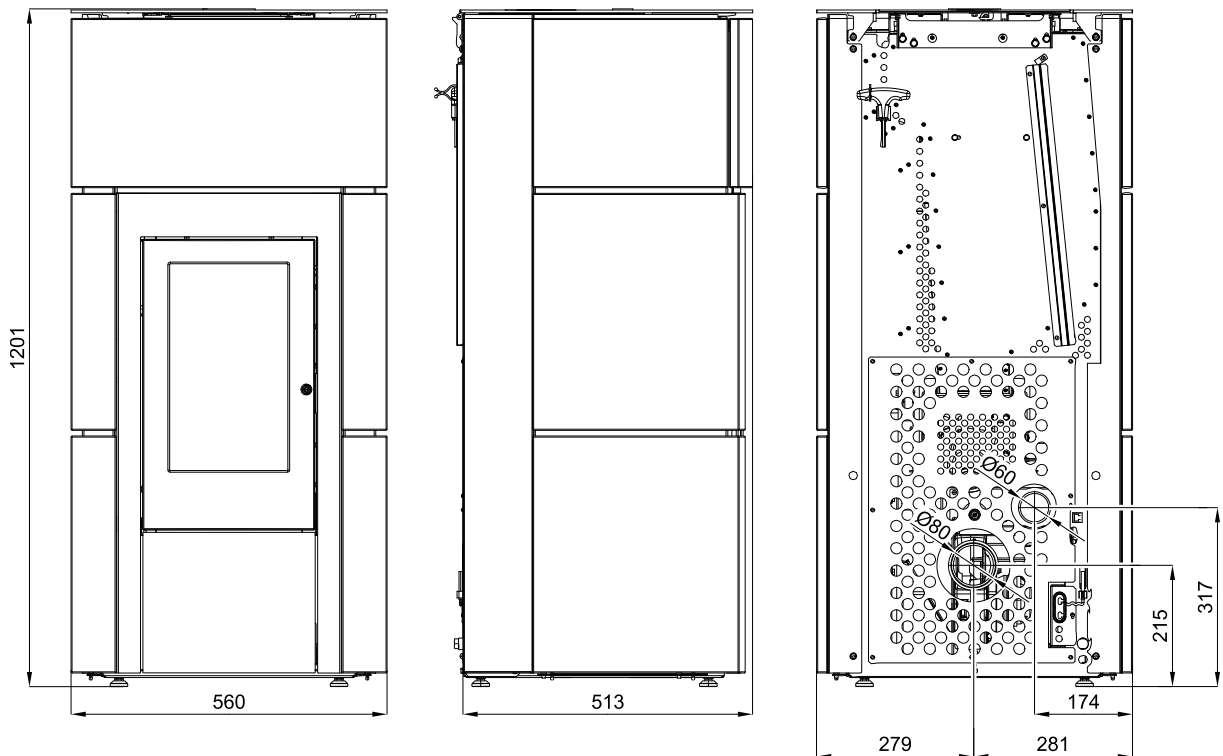

# 3. Cleaning work



## WARNING

**Before starting any cleaning work, the stove must be cool down!**

**Once the cleaning work is completed, the correct operating status of the device must be re-established: Put the combustion pot in correctly, close the combustion chamber door.**

### 3.1. Cleaning the surface

Dirt on the upper surface of the stove may be cleaned off with a damp cloth or if necessary with mild soapy water. You are advised against using corrosive cleaning agents and solvents since these might damage the surfaces.

### 3.2. Cleaning the glass panel

To clean the viewing panel, you must first open the stove door. Dirt on the glass panel can be removed with a glass cleaner or with a damp sponge on which you have sprinkled some of the wood ash present. (Environmentally friendly). Cleaning the glass panel may only be done with a cooled down stove in the OFF operating mode.

### 3.3. Clean combustion chamber “function instruction” Error F040

- The whole combustion space must be cleaned after **30-hours operation at the latest, or once a week.**
- The requirement to clean the fire-box (flickering of the display) appears during heating, in case that the cleaning interval has elapsed.
- After the fire-box has been cleaned, the error message "Clean the fire-box" will be confirmed automatically. The condition for automatic confirmation of this error message is that the fire-box door is opened for more than **60 seconds**. This time is necessary for careful cleaning of the fore-box, including the burner.
- This reset of the operating hours counter occurs even if the cleaning of the combustion chamber is performed before the 30 operating hours have run provided that the stove is in “Off” operating status and the door is open for longer than 60 seconds during cleaning.

### 3.4. Cleaning the combustion pot - weekly

During operation, deposits may form in the combustion pot. How quickly the combustion pot becomes dirty depends solely on fuel quality. The deposits or encrustations must be removed from time to time.



## **WARNING**

---

If this is not done, the clinker will continue to accumulate. Then the device will no longer be able to ignite properly. Pellets can pile up in the combustion pot. In extreme cases, this can reach all the way back to the pellet chute. Backfire in the pellet container and smouldering in the pellet tank might possibly result.

**This will destroy your device and is not covered in your guarantee.**

---



## **WARNING**

---

**Cleaning the combustion pot may only be done with a cooled down stove in “OFF” operating mode. Otherwise there is a risk of burns!**

---

- Take out the burner bowl from the stove.
- Remove the remains of ashes and slag.
- After the cleaning, mount the burner bowl back to its proper position on the burner rest.
- Re-check the proper seating of the burner bowl, in order to avoid any lack of tightness.



# 4. Maintenance work



## WARNING

**Before starting any cleaning work, the stove must be cool down! The mains plug must be pulled out of the power supply socket (always in advance)!**

The frequency of maintenance in turn depends to a large extent on the pellet quality (ash content). Quality pellets have a low ash content of about 0.2-0.3%. However, if the ash content is higher (0.5% and over), the interval from maintenance to maintenance is reduced and the accumulation of ash increases by 2 or 3 times.



## WARNING

**Devices that are not maintained in accordance with our specifications must not be operated. Failure to observe this point will invalidate all guarantee claims.**

## 4.1. Cleaning the flue gas passes



### CAUTION

Check and clean the flue-gas ways, exhaust (flue-gas) fan and flue-gas ducts at the latest after 1000 kg of pellets have been consumed. Clean with a brush or an ash extractor.



### CAUTION

After completion of the cleaning make sure that when putting back the covers, the seals are seated in the right positions. It is essential to replace defective seals.

Please perform the cleaning in two steps:

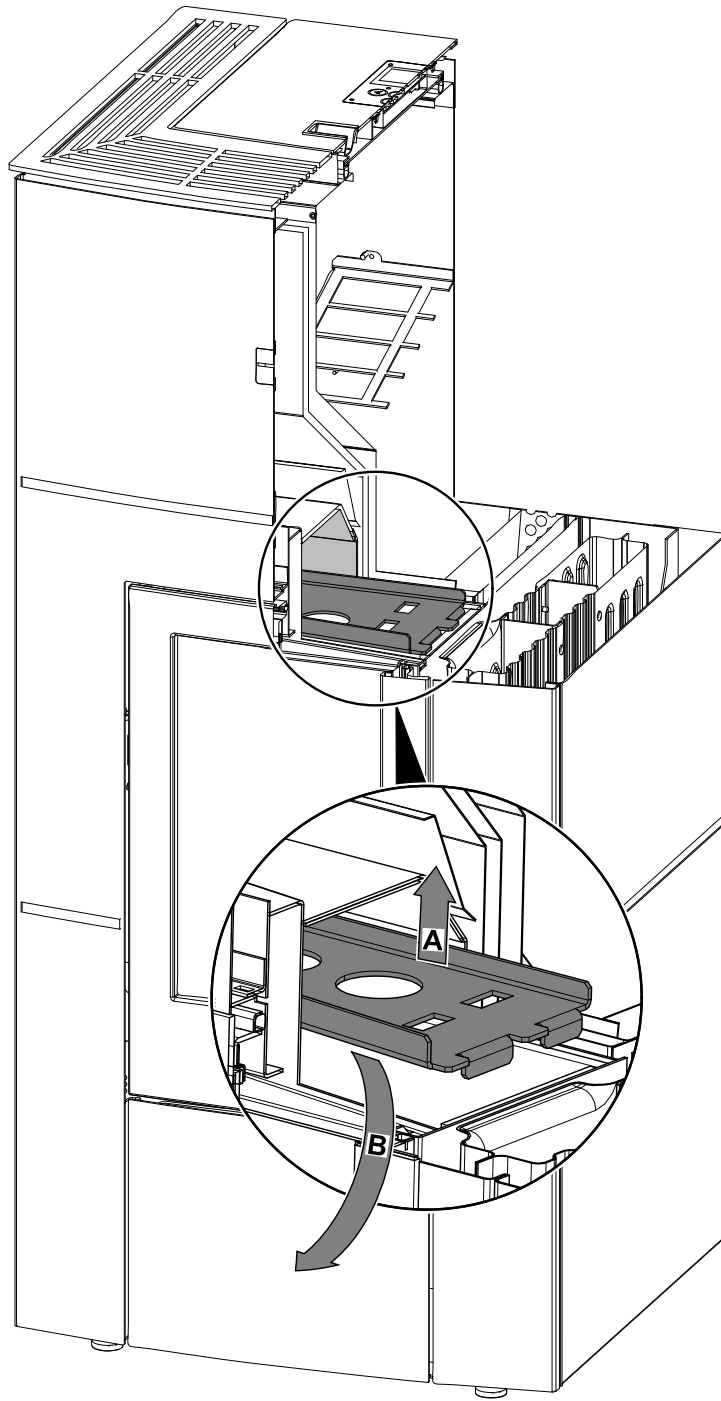
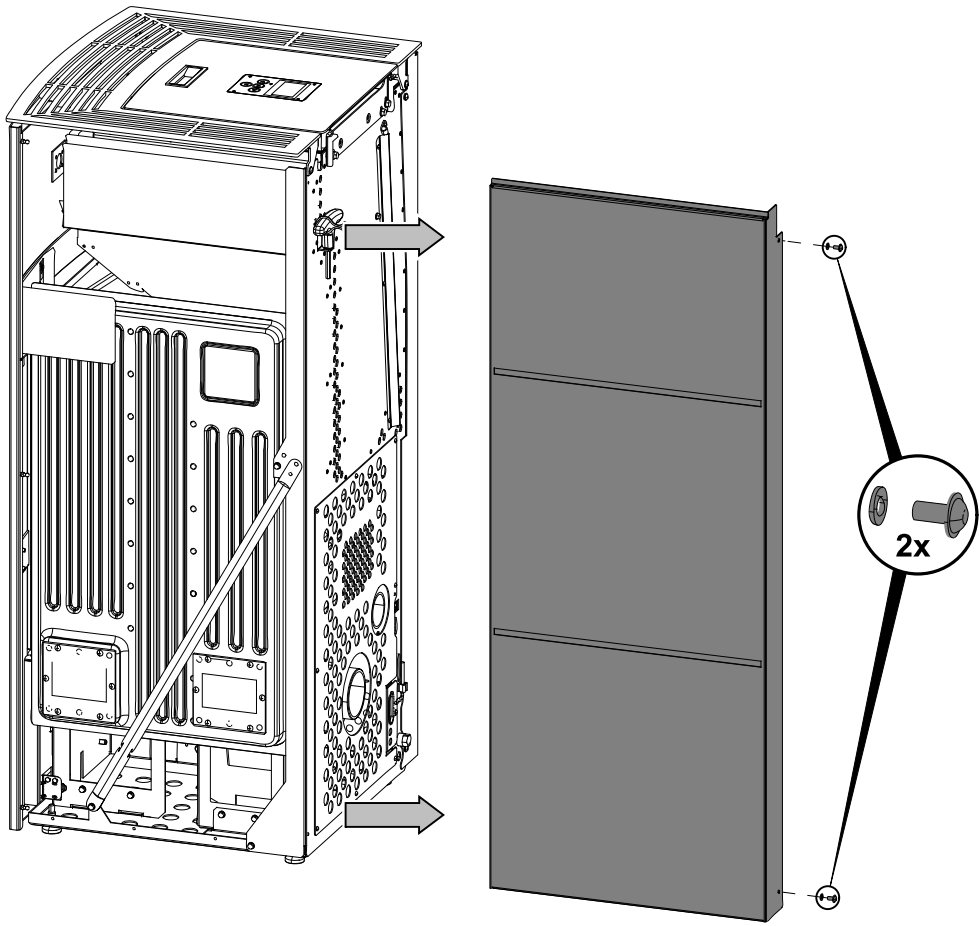
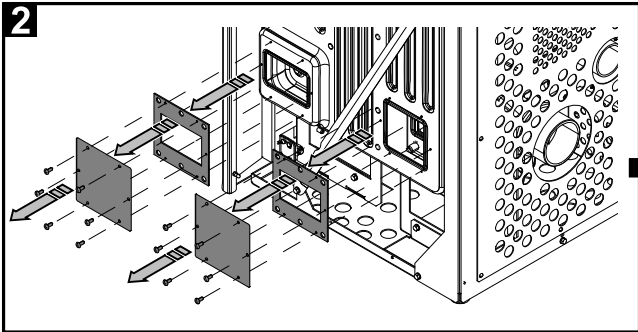

Figure 1: Removing the flue baffle

**1**



**2**



**3**

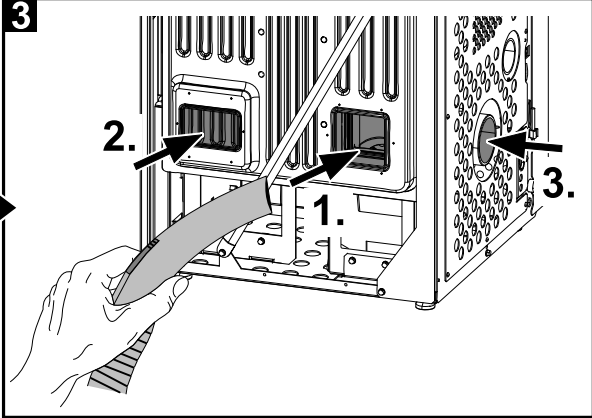

Figure 2a: Removing the side wall (HSP 6 Helena 465.32 RLU)

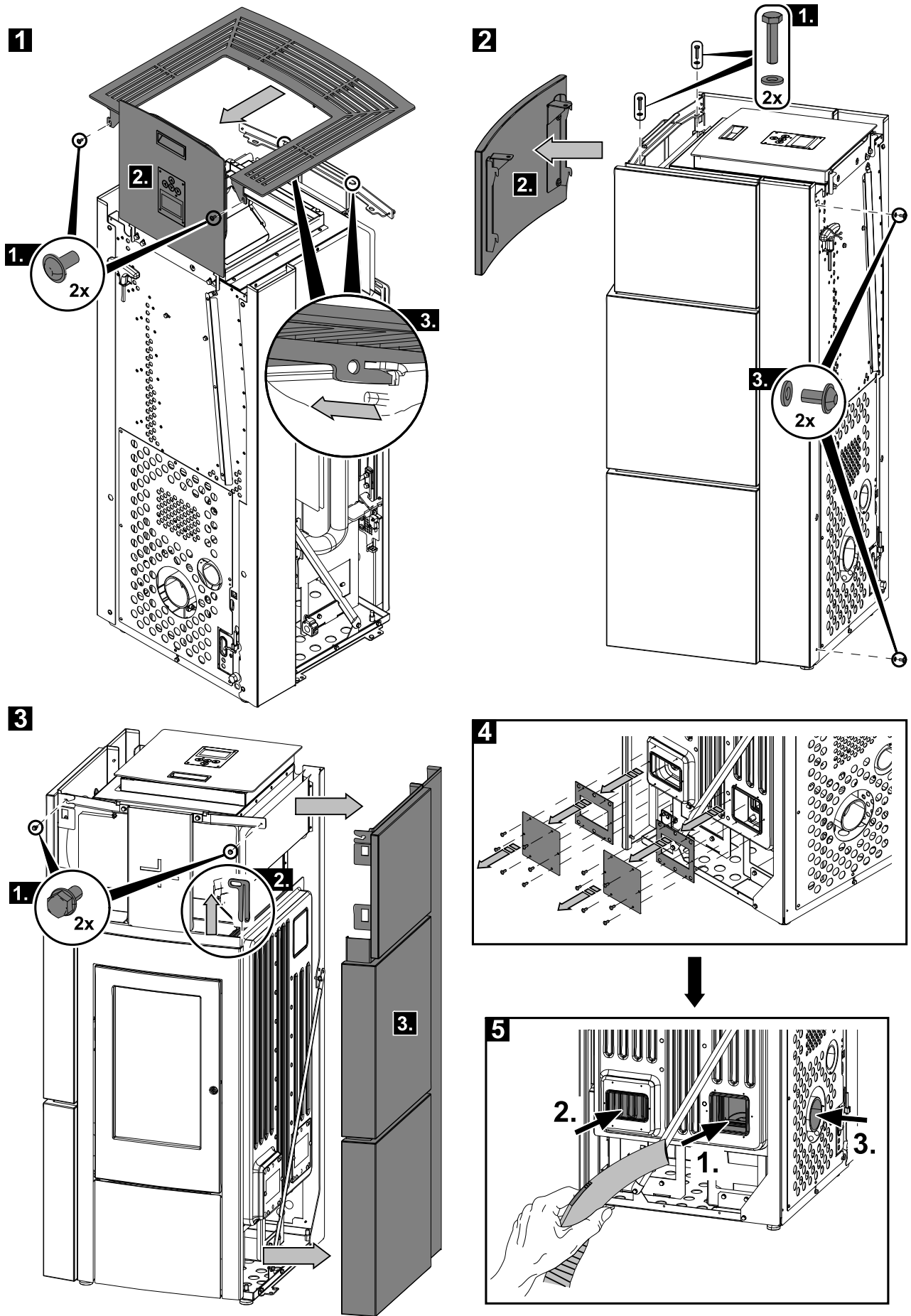
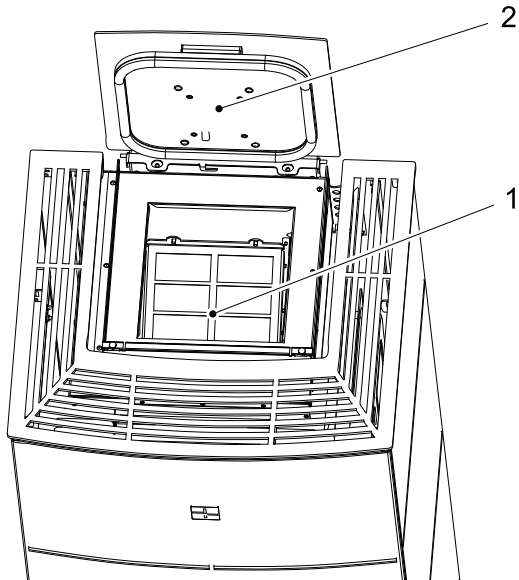

Figure 2b: Removing the side wall (HSP 6 Helena 465.32-C RLU)

## 4.2. Cleaning the pellet container - annual maintenance

- Heat the pellet stove until the storage tank is completely empty.
- Then the protective grille (1) in the pellet tank may be removed.
- Then clean the tank and the intake of the screw conveyor housing with a vacuum cleaner.
- After cleaning, it is essential to put back the protective grille. When doing this, make sure that no screws fall into the pellet tank so as to avoid consequential damage to the screw conveyor.

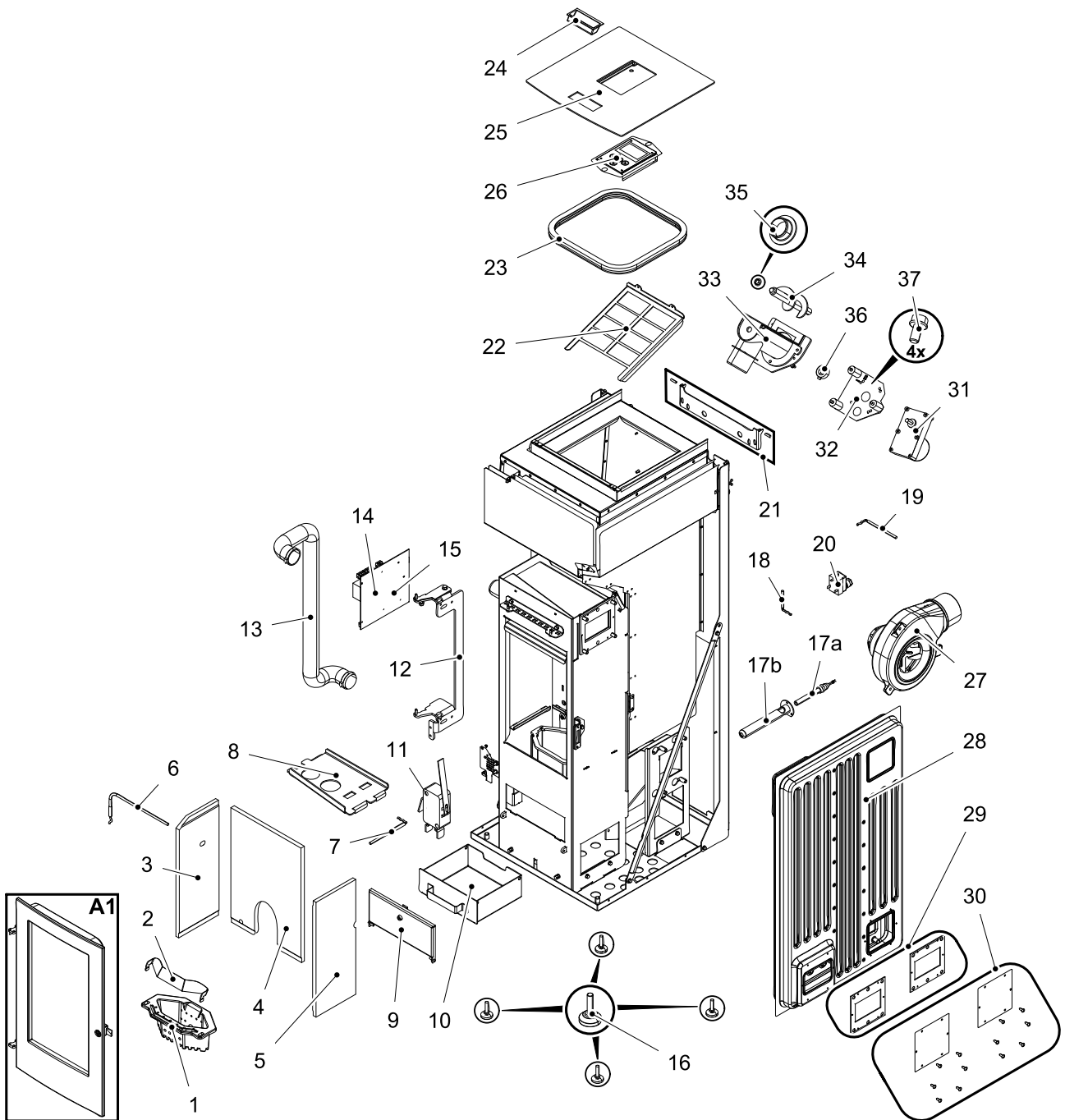

**Figure 3: Pellet tank**

- 1 Protective grille
- 2 Tank cover

# 5. Replacement parts list

## 5.1. Replacement parts list HSP 6 Helena 465.32 RLU (without trim parts)



Pos.	Description	Piece	No. PR
<b>Replacement parts list HSP 6 Helena 465.32 RLU (without trim parts)</b>			
<b>A1</b>	Complete combustion chamber door/anthracite	1 piece	0541908005300
<b>1</b>	Burner cast/anthracite	1 piece	0551908005706

<b>2</b>	Protection grate	1 piece	0551908006709
<b>3</b>	Combustion chamber cladding left	1 piece	0551908005040
<b>4</b>	Combustion chamber cladding back	1 piece	0551908005041
<b>5</b>	Combustion chamber cladding right	1 piece	0551908005039
<b>6</b>	Flame temperature sensor	1 piece	0561008005541
<b>7</b>	Bottom temperature sensor	1 piece	0561008005543
<b>8</b>	Draught baffle plate/anthracite	1 piece	0551908005701
<b>9</b>	Ash-pan door/anthracite	1 piece	0546032015060
<b>10</b>	Ash pan/anthracite	1 piece	0546532008600
<b>11</b>	Door contact switch	1 piece	0089500040005
<b>12</b>	Door hinge (complete)/anthracite	1 piece	0551908005404
<b>13</b>	Hose Meniflex L=710	1 piece	0551908015315
<b>14</b>	Complete control unit	1 piece	0541908005569
<b>15</b>	Backup battery CR 2032	1 piece	-
<b>16</b>	Stand	4 piece	0551908506005
<b>17a</b>	Ignition	1 piece	0541908005202
<b>17b</b>	Lighter case	1 piece	0553808005215
<b>18</b>	Room temperature sensor	1 piece	0089500390005
<b>19</b>	Flue gas thermosensor	1 piece	0561008005540
<b>20</b>	OC	1 piece	0089500080005
<b>21</b>	Cover hinge pins DIN 427 M5x18	1 piece	0543408175015
<b>22</b>	Protective grille	1 piece	0551908005931
<b>23</b>	Seal, tank cover (1100 mm)	1 piece	0546608005189
<b>24</b>	Grip	1 piece	0089500940005
<b>25</b>	Tank cover/anthracite	1 piece	0546532606190
<b>26</b>	Operator console	1 piece	0571207005510
<b>27</b>	Induced draught fan	1 piece	0561008005807
<b>28</b>	Heat exchanger	1 piece	0561008007072
<b>29</b>	Seal - set	1 piece	0571207006030
<b>30</b>	Tank cover + screw DIN 7981 ST 4,8x13 - set	1 piece	0561008016043
<b>31</b>	Screw conveyor motor	1 piece	0089500000006
<b>32</b>	Motor plate - set	1 piece	0551908007080
<b>33</b>	Conveyor	1 piece	0571207016060
<b>34</b>	Screw conveyor	1 piece	0571207005030
<b>35</b>	Lower screw conveyor bearing	1 piece	0571207005027
<b>36</b>	Collet	1 piece	0089000345000
<b>37</b>	Screw UN5950 M5x10	4 piece	-

## 5.2. Detail A1

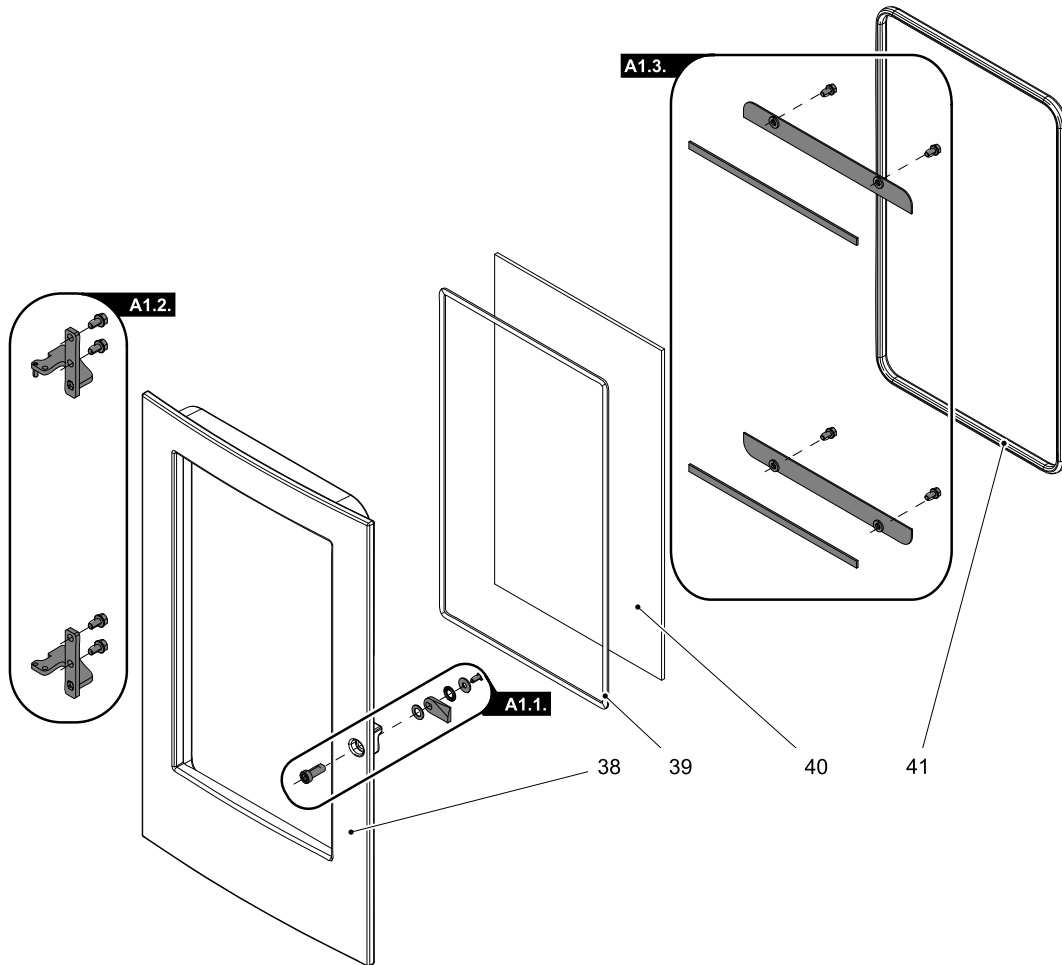

Pos.	Description	Piece	No. PR
<b>Detail A1</b>			
<b>A1.1.</b>	Screwing door — Set	1 piece	0541908305001
<b>A1.2.</b>	Door hinge/anthracite - Set	1 piece	0541908005340
<b>A1.3.</b>	Glass holder/anthracite - Set	1 piece	0551908005308
<b>38</b>	Combustion chamber door/anthracite	1 piece	0541908005220
<b>39</b>	Seal glass 10x4 mm (900 mm)	1 piece	0040210040005
<b>40</b>	Door glass (383x224x4)	1 piece	0551908005305
<b>41</b>	Seal door 11 mm (1306 mm)	1 piece	0040300110006



### 5.3. Replacement parts list HSP 6 Helena 465.32 RLU

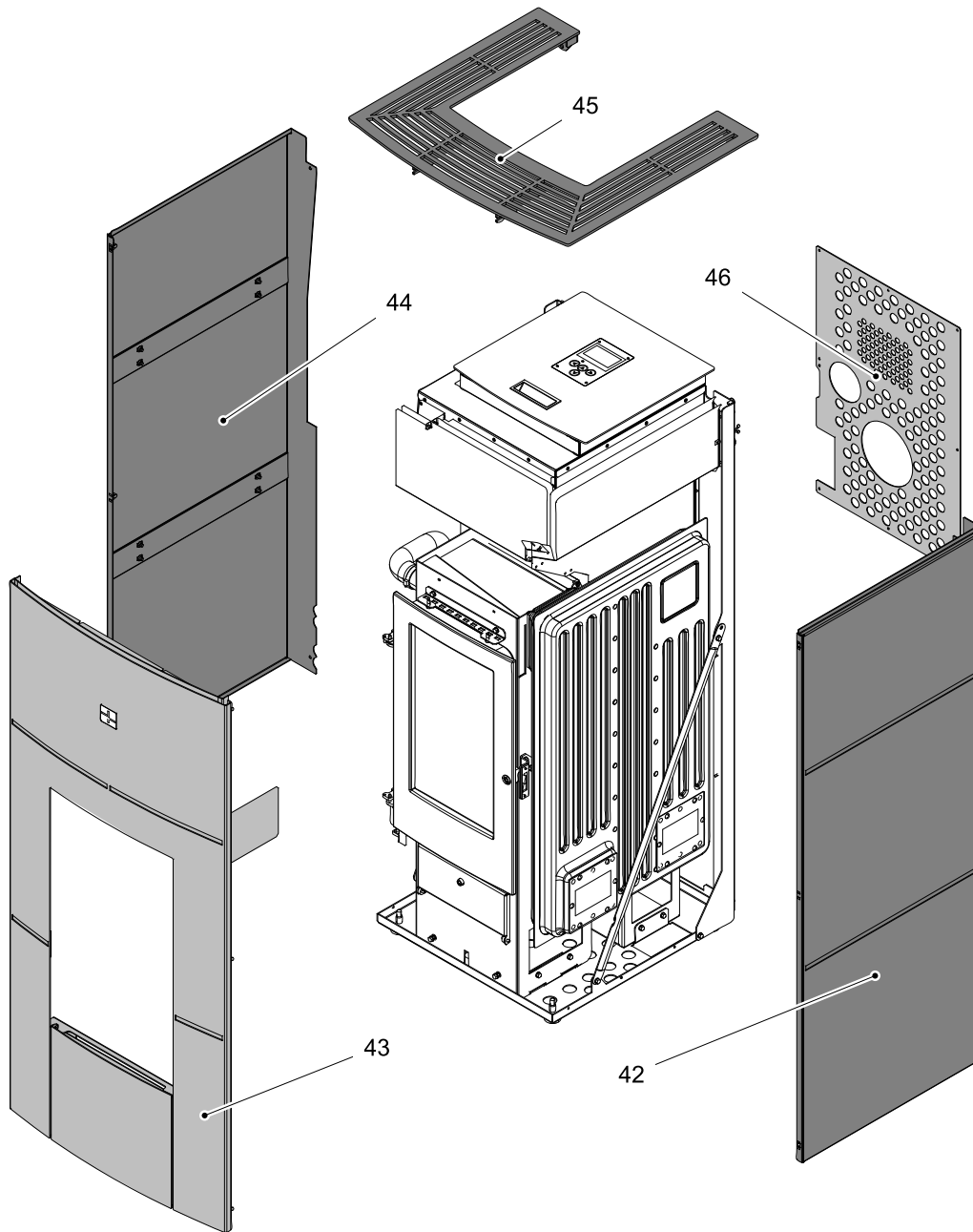

Pos.	Description	Piece	No. PR
<b>Replacement parts list HSP 6 Helena 465.32 RLU</b>			
<b>42</b>	Side wall right/anthracite-black	1 piece	0546532615200
<b>42</b>	Side wall right/anthracite-white	1 piece	0546532616200
<b>43</b>	Front plate/anthracite-black	1 piece	0546532616120
<b>43</b>	Front plate/anthracite-white	1 piece	0546532617120
<b>44</b>	Side wall left/anthracite-black	1 piece	0546532615250
<b>44</b>	Side wall left/anthracite-white	1 piece	0546532616250
<b>45</b>	Cover plate/anthracite	1 piece	0546532615160
<b>46</b>	Back wall	1 piece	0546532615118

## 5.4. Replacement parts list HSP 6 Helena 465.32-C RLU

Replacement parts list

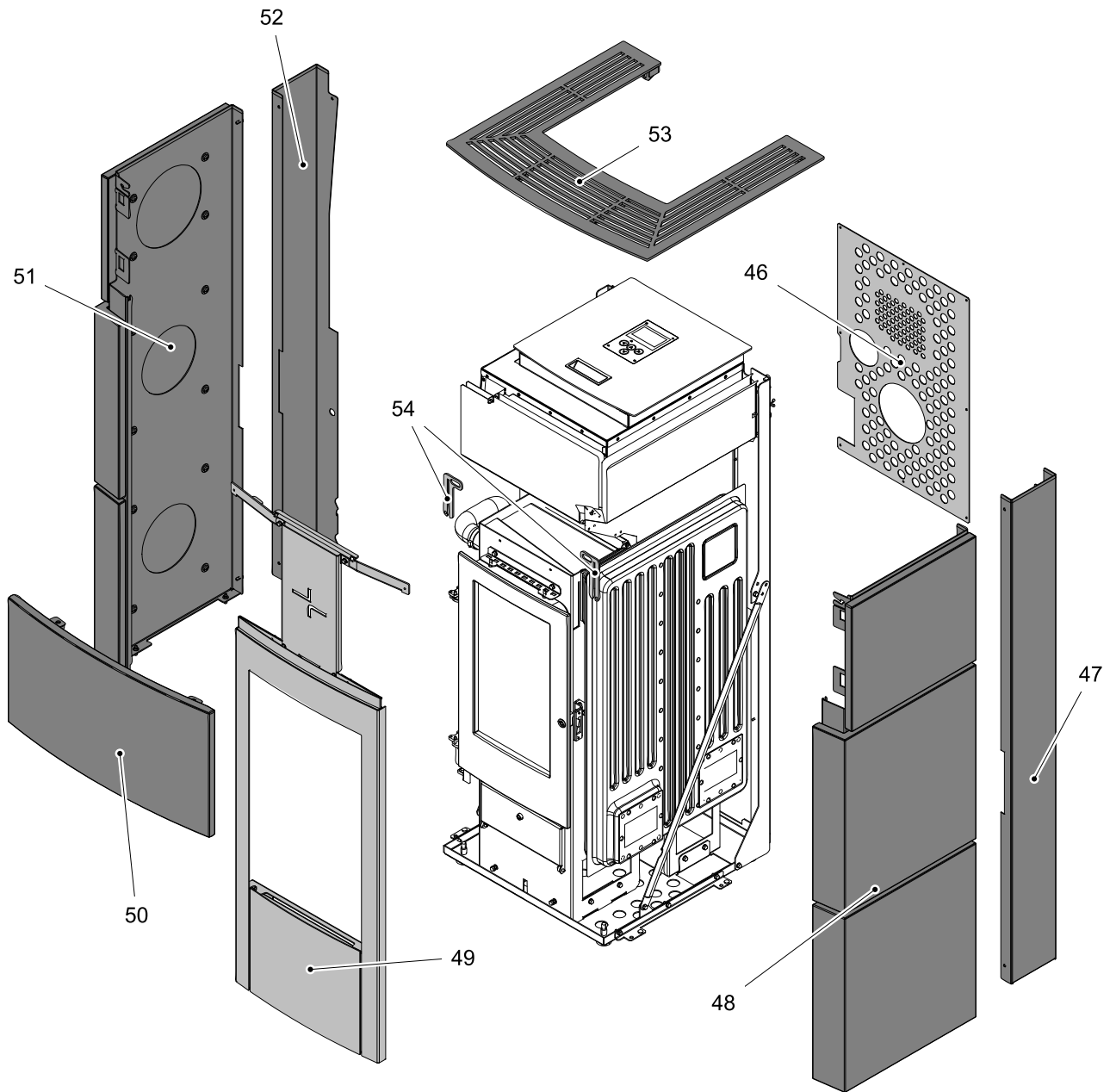

**GB**

Pos.	Description	Piece	No. PR
<b>Replacement parts list HSP 6 Helena 465.32-C RLU</b>			
<b>46</b>	Back wall	1 piece	0546532615118
<b>47</b>	Side wall rear right/anthracite	1 piece	0546532625202
<b>48</b>	Side wall C right/anthracite-metallic	1 piece	0546532625201
<b>48</b>	Side wall C right/white	1 piece	0546532626201
<b>49</b>	Front plate/anthracite	1 piece	0546532625120
<b>50</b>	Front plate C upper/anthracite-metallic	1 piece	0546532625207
<b>50</b>	Front plate C upper/white	1 piece	0546532626207
<b>51</b>	Side wall C left/anthracite-metallic	1 piece	0546532625251

<b>51</b>	Side wall C left/white	1 piece	0546532626251
<b>52</b>	Side wall rear left/anthracite	1 piece	0546532625252
<b>53</b>	Cover plate/anthracite	1 piece	0546532625160
<b>54</b>	Clasp/anthracite	2 piece	0546532625260

# 6. Circuit diagram

Circuit diagram IO 33.3

Circuit diagram

GB

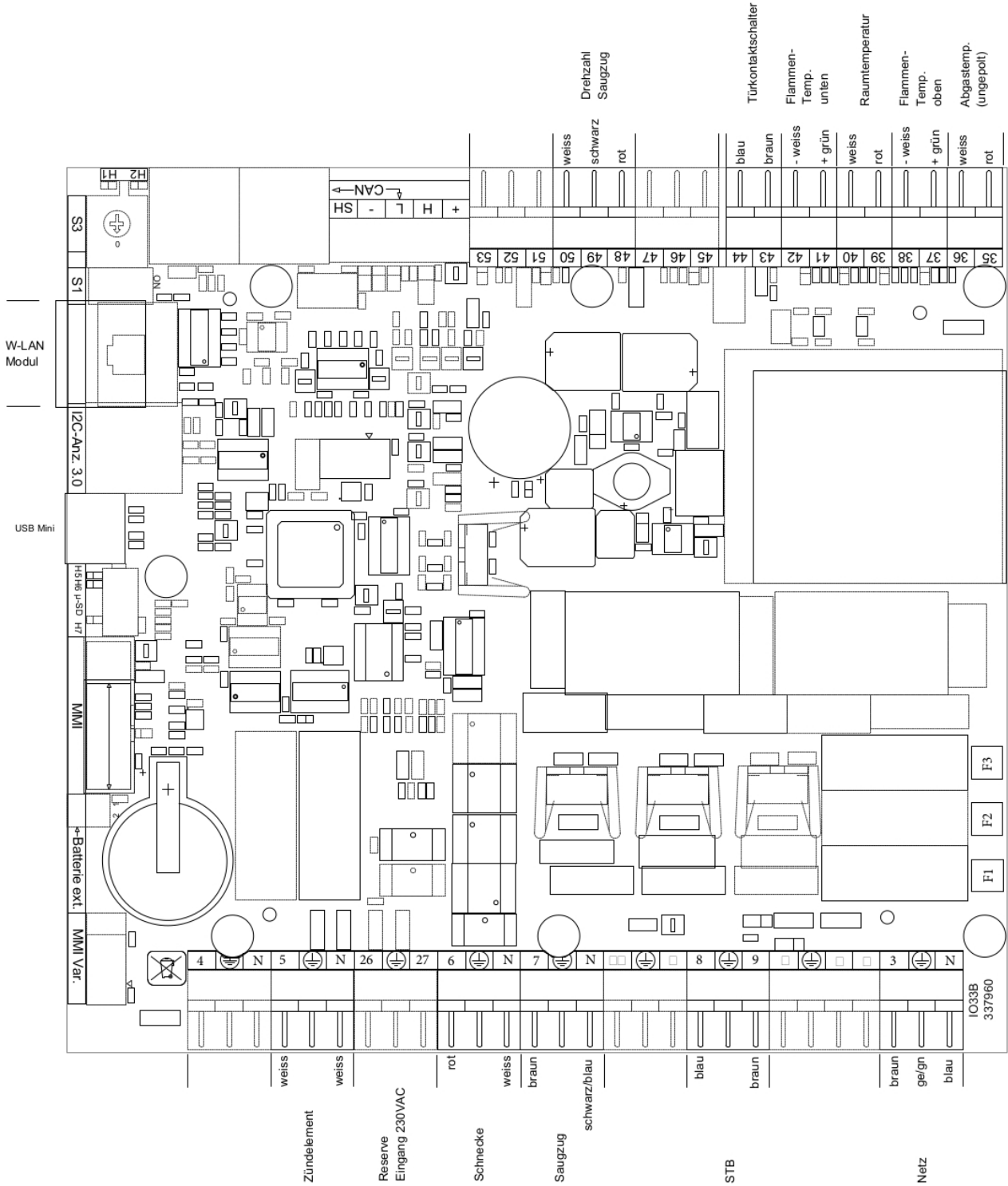

**Description Circuit diagram:**

No.:	Description Cable harness
3	Mains plug / mains filter
5	Electric ignition
6	Screw conveyor motor
7	Induced draught
8/9	OC
35/36	Flue gas temperature sensor
37/38	Flame temperature sensor
39/40	Room temperature sensor
41/42	Bottom flame temperature sensor
43/44	Door contact switch
48-50	Flue gas fan rotation speed
F1	Fuse T 3,15 A ignition, induced draught fan, screw conveyor motor
F3	Fuse T 0,315 A operator console





# HAAAS + SOHN

Montageanleitung - Notice de montage - Istruzioni di montaggio -  
Assembly Instructions - Upute za montažu - Navodilo za montažo

## HSP 6 Helena 465.32 C RLU

 **4x**  
M5x10 DIN6921

 **2x**  
M6x25 DIN933

 **2x**  
D125a D6.4

**1x**

**1x**

**1**

**1x**

**1**  
**2x**

**3.**

**2**

**4x**



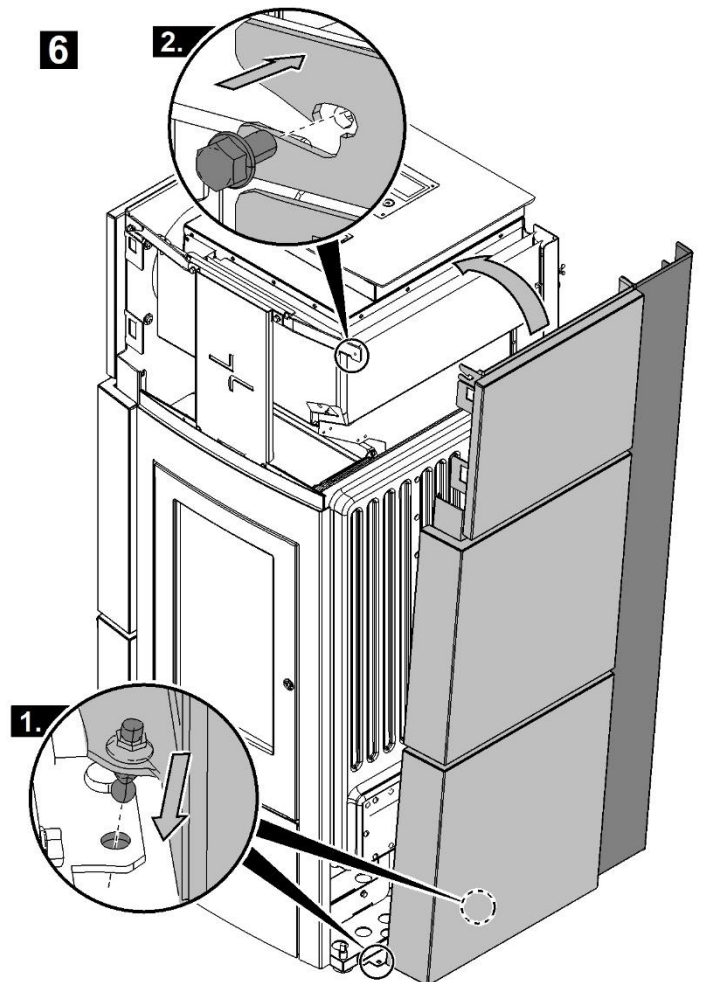
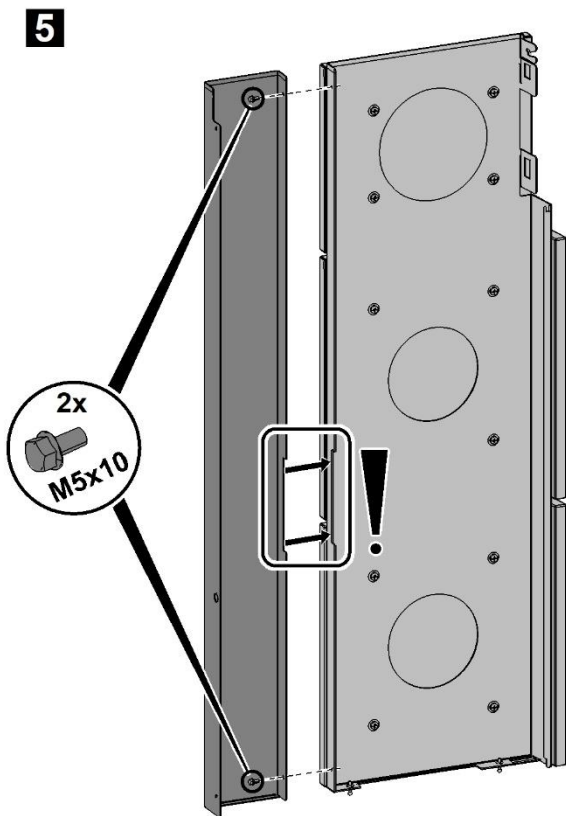
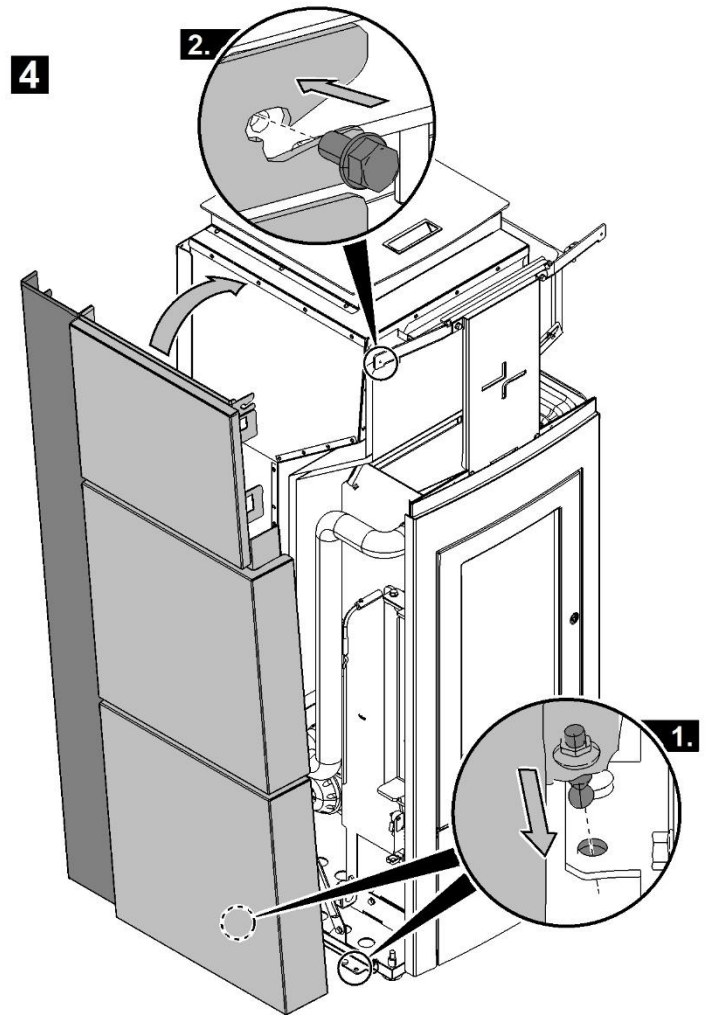
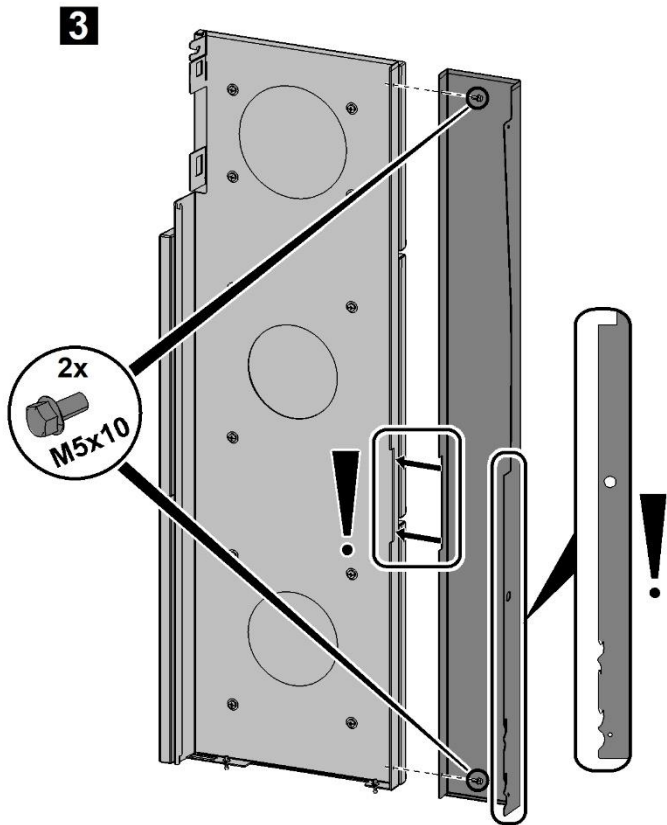

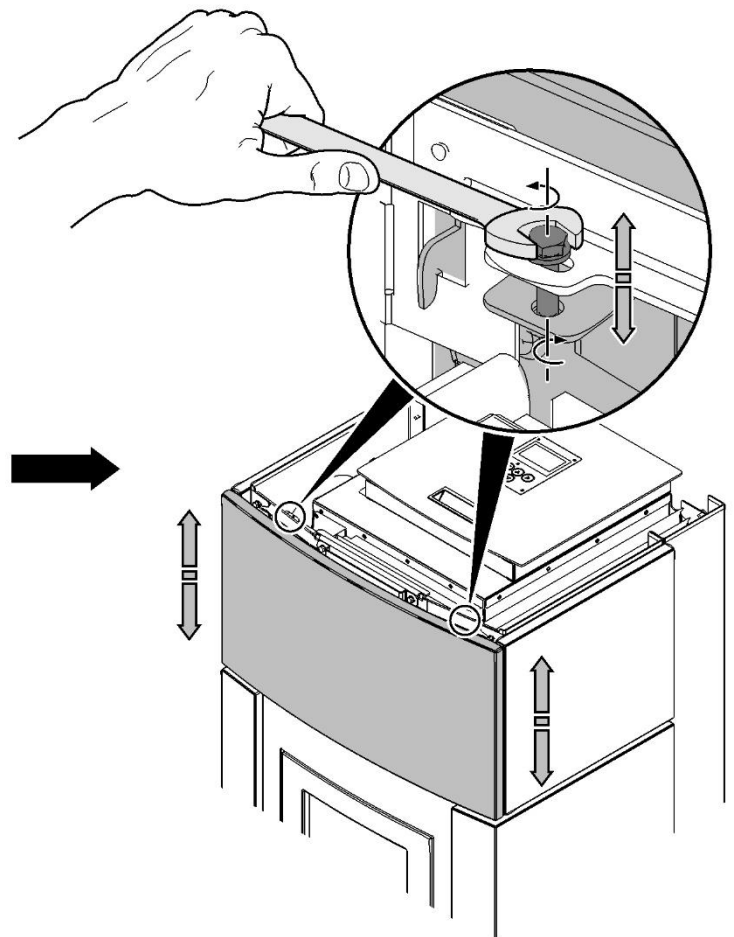
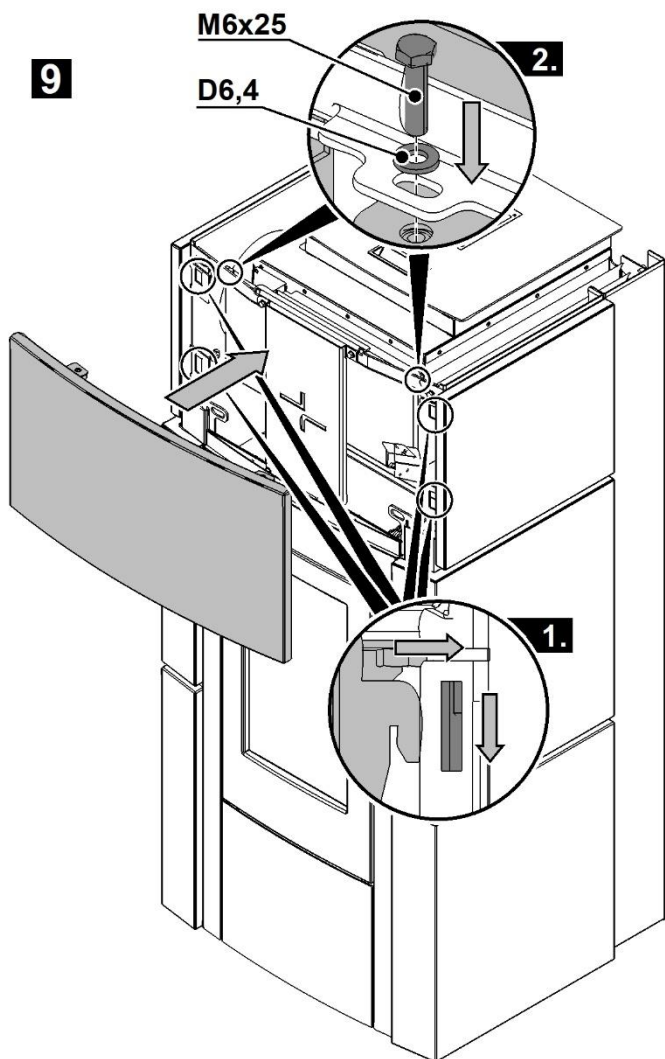
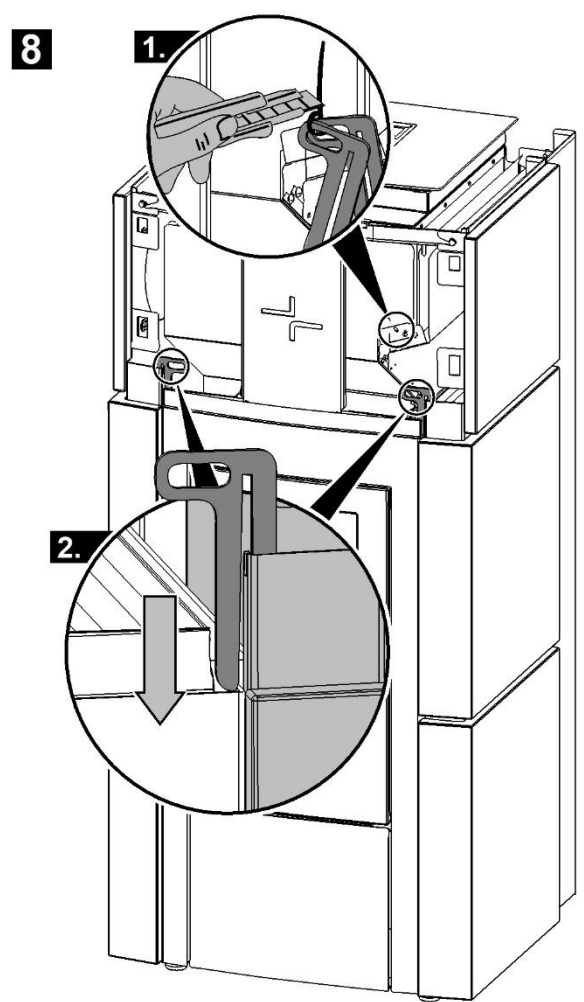
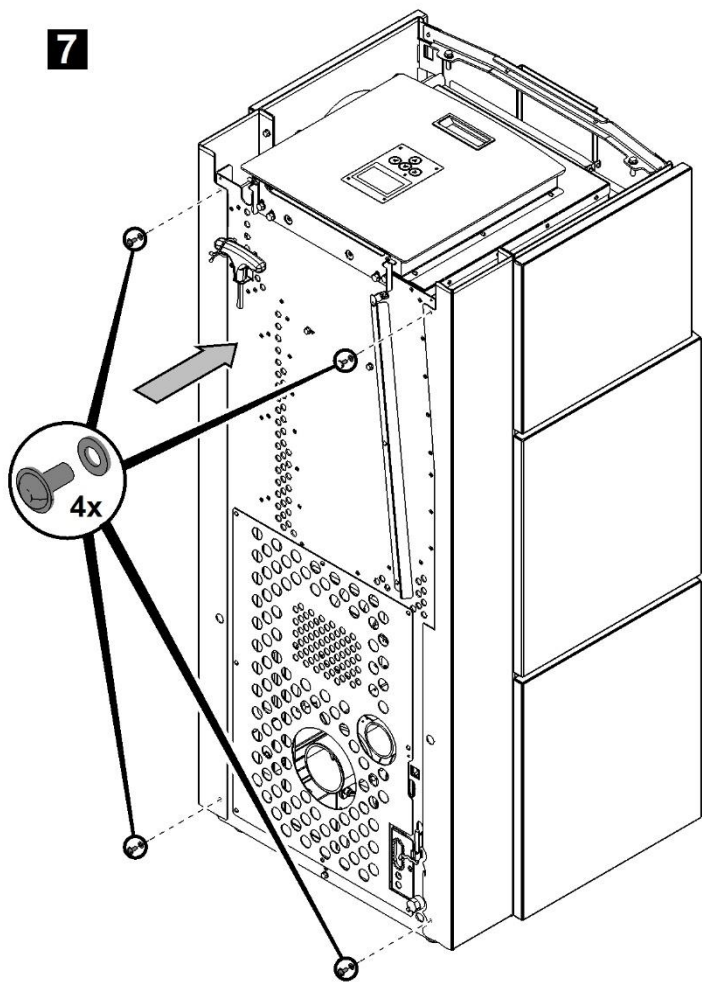

**10**

