

INSERT

FRESIA 70 AIR 9 S1

PART 1 - REGULATIONS AND ASSEMBLY

Instructions in English

RED
HEATING



8901845800

TABLE OF CONTENTS

TABLE OF CONTENTS	II
INTRODUCTION	1
1-WARNINGS AND WARRANTY CONDITIONS	2
2-INSTALLATION	8
3-DRAWINGS AND TECHNICAL SPECIFICATIONS	17
4-UNPACKING	19
5-OVERALL DIMENSIONS	20
6-PRELIMINARY OPERATIONS	23
7-TYPE OF FASTENING	26
8-ACCESSORIES	33
9-ASSEMBLING THE ACCESSORIES	35
10-INSERT EXTRACTION AND LOADING PELLETS IN COLD MACHINE	36
11-DOOR OPENING	38
12-ELECTRICAL CONNECTION	39
13-CLADDING	42

INTRODUCTION

Dear Customer,

our products are designed and manufactured in compliance with European reference standards for construction products (EN13240 for wood-burning stoves, EN14785 for pellet-burning appliances, EN13229 for fireplaces/wood-burning inserts and EN 12815 for wood-burning range cookers), with high quality materials and extensive experience in transformation processes. The products also meet the essential requirements of Directive 2006/95/EC (Low Voltage) and Directive 2004/108/EC (Electromagnetic Compatibility).

To get the best performance, we suggest you read the instructions in this manual carefully.

This installation guide is an integral part of the product: ensure that the manual is always supplied with the appliance, even if it changes owner. If the manual is lost, you can request another copy from the local Technical Dept. or download it directly from the company's website.

All local regulations, including those referring to national and European standards, must be observed when installing the appliance.

In Italy, for the installation of systems with a biomass below 35KW, refer to the Ministerial Decree 37/08 and the qualified installation technician with the suitable requirements must issue a certificate of compliance for the system installed. (By system we intend Stove+Flue+Air vent).

REVISIONS TO THE PUBLICATION

The content of this manual is strictly technical and the property of MCZ Group Spa.





No part of this manual may be translated into other languages, adapted and/or reproduced, even in part and/or other mechanical or electronic forms, for photocopies, recordings or other, without the prior written authorisation from MCZ Group Spa.

The company reserves the right to make changes to the product at any time without prior notice. The proprietary company reserves its rights according to law.

CARE OF THE MANUAL AND HOW TO CONSULT IT

- Take care of this manual and store it in an easily and quickly accessible place.
- Should this manual be lost or destroyed, request a copy from your retailer or directly from the authorised technical support Centre. It can also be downloaded from the company's website.
- "**Bold text**" requires special attention.
- "*Text in italics*" is used to draw attention to other paragraphs in the manual or for any additional clarifications.
- "Note" provides the reader with additional information.

SYMBOLS USED IN THE MANUAL

	ATTENTION: carefully read the corresponding message as failure to comply with the information provided may result in serious damage to the product and danger to the persons who use it.
	INFORMATION: failure to comply with these provisions will compromise use of the product.
	OPERATING SEQUENCES: sequence of buttons to be pressed to access the menus or perform adjustments.
	MANUAL carefully read this manual or the relative instructions.



SAFETY WARNINGS

- **Installation, electrical connection, operating check and maintenance must only be carried out by authorised and qualified personnel.**
- **Install the product in accordance with all local and national legislation and regulations in force in the region or state.**
- Only use the fuel recommended by the manufacturer. The product must not be used as an incinerator.
- It is strictly forbidden to use alcohol, petrol, liquid fuel for lanterns, diesel, bio-ethanol, fluids for lighting charcoal or similar liquids to light/rekindle the flame in these devices. Keep these flammable liquids well away from the appliance when in use.
- Do not put any fuel other than wood pellets in the tank.
- The instructions provided in this manual must always be complied with to ensure the product and any electronic appliances connected to it are used correctly and accidents are prevented.
- **This appliance can be used by children aged 8 years and above and persons with reduced physical, sensory or mental capabilities or lack of experience and knowledge provided they are supervised or have been given instructions regarding use of the appliance in a safe way and understand the hazards involved. Children must not play with the appliance. Cleaning and maintenance to be performed by the user, just not be carried out by children without supervision.**
- The user, or whoever is operating the product, must read and fully understand the contents of this installation and user manual before performing any operation. Errors or incorrect settings may cause hazardous conditions and/or incorrect operation.
- Do not climb on or lean on the product.

1-WARNINGS AND WARRANTY CONDITIONS

- Do not dry linen on the product. Any drying racks or the like must be kept at a safe distance from the product. **Fire hazard.**
- *All liability for improper use of the product is entirely borne by the user and relieves the manufacturer of any civil and criminal liability.*
- Any type of tampering or unauthorised replacement with non-original spare parts may be hazardous for the operator's safety and relieves the company of any civil and criminal liability.
- Many surfaces of the product get very hot (door, handle, glass, smoke outlet pipes, etc.). **Avoid coming into contact with these parts without adequate protective clothing or suitable equipment, such as gloves with thermal protection** or "cold handle" operating systems.
- **It is forbidden to operate the product with the door open or the glass broken.**
- **The doors/covers on the appliance must remain closed when it is not being used.**
- The product must be powered by an electrical system that is equipped with an effective earthing device.
- Switch the product off in the event of a fault or malfunction.
- Accumulated unburnt pellets in the burner after each "failed ignition" must be removed before lighting again. Check that the burner is clean and positioned properly before lighting again.
- Do not wash the product with water. Water may penetrate inside the unit and damage the electrical insulation and cause electric shocks.
- Do not stand for a long time in front of the product in operation. Do not overheat the room you are in and where the product is installed. This may cause injuries and health problems.
- Install the product in a location that does not present a fire hazard and is equipped with power and air supplies and smoke outlets.
- In the event of fire in the chimney, turn off the device, disconnect it from the mains and do not open the hatch. Then contact the competent authorities.

1-WARNINGS AND WARRANTY CONDITIONS

- The product and the cladding must be stored in a dry place and must not be exposed to weathering.
- It is recommended not to remove the feet that support the product in order to ensure adequate insulation, especially if the flooring is made of flammable materials.
- In the event of a malfunction of the ignition system, do not force it on by using flammable materials.
- Special maintenance must only be performed by authorised and qualified personnel.
- Assess the static conditions of the surface on which the weight of the product will rest and provide suitable insulation if it is made of flammable material (e.g. wood, fitted carpet or plastic).
- Live electrical parts: only power the product once it has been fully assembled.
- Disconnect the product from the 230V power supply before performing any maintenance operations.
- Improper use or poor maintenance of the product can cause hazardous situations to arise.
- **It is forbidden to manually load the fuel into the brazier. Failure to follow this warning can lead to hazardous situations.**
- **Before the product is restarted, always remove any unburned pellets building up in the brazier due to failed ignition, the emptying of the hopper or any situation that may cause this condition.**

1-WARNINGS AND WARRANTY CONDITIONS

INFORMATION:

Please contact the retailer or qualified personnel authorised by the company to resolve a problem.

- Only use the fuel specified by the manufacturer.
- When the product is switched on for the first time, it is normal for it to emit smoke due to the paint heating for the first time. Therefore make sure the room in which it is installed is well ventilated.
- Check and clean the smoke outlet pipes regularly (chimney fitting).
- The product is not a cooking appliance.
- Always keep the cover of the fuel tank closed.
- Store this installation and user manual with care as it must accompany the product for the duration of its useful life. If the product is sold or transferred to another user, always ensure the manual is also handed over.

INTENDED USE

The product only works with wood pellets and must be installed indoors.

PRODUCT PERFORMANCE CHECKS.

All our products undergo ITT TESTS carried out by a notified laboratory (system 3) and in accordance with (EU) Regulation number 305/2011 "Construction products", according to standard EN 14785:2006 (pellets) and "Machinery Directive" EN 303-5 (boilers).

In the case of tests for any market surveillance or inspections by third parties, please take the following warnings into account:

- to reach the declared performance levels, the product must perform an operating cycle of at least 15/20 hours beforehand
- use the average draught of the combustion smokes specified in the "product technical specifications" table
- the type of pellets used must comply with current EN ISO 17225-2 regulations
- the amount of fuel may vary according to the length and calorific value of the fuel. This may require some adjustments to stay in line with the hourly consumption specified in the "product technical specifications" table. A1 pellets ensure an overall calorific value within tight margins compared to the test pellets used. However, size considerably affects performance, therefore on average it must not be less than 24 mm long and with a 6mm diameter
- in the case of a wood-burning product, check the correct residual moisture content of the fuel, which must not be less than 12% or more than 20%. As the moisture increases, different combustion air settings are required. The settings are to be carried out via the combustion air register, thereby modifying the mixture between primary and secondary air.
- it is required to check the operation of devices that can affect performance (for example air fans or electrical safety devices) in case of damage due to handling.
- maximum performance can be achieved at the maximum flame and ventilation power.
- strictly comply with the withdrawal points required by regulations both in terms of emissions and temperature.

WARRANTY CONDITIONS

The company guarantees the product, **with the exception of parts subject to normal wear** (listed on the following page), for a period of **2 (two) years** from the date of purchase attested by:

- a document to serve as proof of purchase (invoice and/or receipt) that shows the name of the vendor and the date on which the purchase was made;
- forwarding of the completed warranty certificate within 8 days of purchase.

Furthermore, in order for the guarantee to be valid, the device must be installed and calibrated by qualified personnel, and where necessary, the user must be issued with a declaration of conformity and correct functioning of the product.

We recommend testing the product before completion with the relative finishes (cladding, painting of walls, etc.).

1-WARNINGS AND WARRANTY CONDITIONS

Installations that do not meet the current standards, improper use and lack of maintenance as expected by the manufacturer, void the product warranty.

The warranty is valid on the condition that the instructions and warnings contained in the user and maintenance manual are observed, and therefore the product is used correctly.

Replacement of the entire system or repair of one of its components does not extend the warranty period, and the original expiry date remains unchanged.

The warranty covers the replacement or free repair **of parts recognised as being faulty at source due to manufacturing defects**. In the event of a fault, to benefit from the warranty, the customer must keep the warranty certificate and provide it along with the document given at the time of purchase to the Technical Support Centre.

EXCLUSIONS

The warranty does not cover malfunctions and/or damage to the appliance that arise due to the following causes:

- Damage caused during transport and/or handling
- all parts that develop faults due to negligence or improper use, incorrect maintenance, installation that does not comply with the manufacturer's instructions (always refer to the installation guide provided with the appliance)
- incorrect sizing with regard to the use or faults in the installation or failure to implement the necessary devices to ensure proper execution
- improper overheating of the equipment, i.e. the use of fuels not conforming to the types and quantities indicated in the instructions provided
- further damage caused by incorrect user operations in an attempt to fix the initial fault
- worsening of the damage caused by the user continuing to operate the appliance even after the fault has been detected
- in the presence of a boiler, any corrosion, incrustations or breakage caused by water flow, condensation, hardness or acidity of the water, improperly performed descaling treatments, lack of water, mud or limescale deposits
- inefficiency of chimneys, flues or parts of the system affecting the appliance
- damage caused by tampering with the appliance, atmospheric agents, natural disasters, vandalism, electrical discharges, fires, faults in the electric and/or hydraulic system.
- Failure to have yearly stove maintenance performed by an authorised technician or qualified personnel shall render the warranty void.

The following are also excluded from this warranty:

- parts subject to normal wear such as gaskets, glass, cladding and cast iron grilles, painted, chrome-plated or gilded parts, handles and electric cables, bulbs, indicator lights, knobs, all parts which can be removed from the firebox.
- Variations in colour of the painted or ceramic/serpentine parts and crazed ceramics as they are natural characteristics of the material and product use.
- masonry work
- system parts (if present) not supplied by the manufacturer

Any technical operations on the product to remove the aforementioned defects and consequent damage must be agreed upon with the Technical Support Centre, who reserves the right to accept the relative appointment or not. However, said operations shall not be carried out under warranty but as technical support to be granted as part of any potentially and specifically agreed conditions and in accordance with the fees in force for the work to be carried out.

The user will also be charged for any costs incurred to remedy the incorrect technical operations, tampering or damage to the appliance, not attributable to original faults.

Save for the legal or regulatory limits, the warranty does not cover the containment of atmospheric and acoustic pollution.

The company declines all liability for any damage which may be caused, directly or indirectly, to persons, animals or objects as a consequence of non compliance with any provision specified in the manual, especially warnings regarding installation, use and maintenance of the appliance.

1-WARNINGS AND WARRANTY CONDITIONS

SPARE PARTS

In the event of a malfunction, consult the retailer who shall forward the call to the technical support centre.

Only use original spare parts. The retailer or support centre can provide all necessary information regarding spare parts.

We do not recommend waiting for the parts to get worn out before having them replaced. It is crucial to perform regular maintenance checks.



The company declines all liability if the product and any other accessory is used improperly or modified without authorisation.

All parts must be replaced with original spare parts.

Information for management of electric and electronic appliance waste containing batteries or accumulators



This symbol, which is used on the product, batteries, accumulators or on the packaging or documents, means that at the end of its useful life, this product, the batteries and the accumulators included must not be collected, recycled or disposed of together with domestic waste.

Improper management of electric or electronic waste or batteries or accumulators can lead to the leakage of hazardous substances contained in the product. For the purpose of preventing damage to health or the environment, users are kindly asked to separate this equipment and/or batteries or accumulators included from other types of waste and to arrange for disposal by the municipal waste service. It is possible to ask your local dealer to collect the waste electric or electronic appliance under the conditions and following the methods provided by national laws transposing the Directive 2012/19/EU.

Separate waste collection and recycling of unused electric and electronic equipment, batteries and accumulators helps to save natural resources and to guarantee that this waste is processed in a manner that is safe for health and the environment.

For more information about how to collect electric and electronic equipment and appliances, batteries and accumulators, please contact your local Council or Public Authority competent to issue the relevant permits.

WHY SEALED

Products constructed with a perfectly sealed structure do not consume the room's oxygen but draw all the air from the outer environment (if suitably ducted) and may therefore be installed in all houses that require a high degree of insulation such as "passive" or "high energy efficiency" houses. Thanks to this technology there is no risk of smoke emissions in the room, hence no air inlets and relevant ventilation grilles are required in the installation premises.

Consequently, there will be no more draughts of cold air in the room, which make it less comfortable and reduce the overall efficiency of the system. The sealed stove may even be installed in the presence of forced ventilation or in premises that might have negative pressure with respect to the outside.

2-INSTALLATION



The instructions in this chapter refer explicitly to the Italian installation regulation UNI 10683. In any case, always observe the regulations in force in the country of installation.

PELLETS

Wood pellets are manufactured by extruding sawdust which is produced during the processing of natural dried wood (without paint). The compactness of the material is guaranteed by the lignin contained in the wood itself and allows the pellets to be produced without glue or binders.

The market offers different types of pellets with characteristics that vary according to the wood mixtures used. The most common diameter on the market is 6 mm (although 8 mm diameter is also available) with a length, on average, between 3 and 40 mm. A good quality pellet has a density of between 600 and 750 or more kg/cubic metres and a moisture content that accounts for 5 to 8% of its weight.

Pellets have technical advantages besides being an ecological fuel, as the wood residue is used completely, thereby achieving cleaner combustion than that of fossil fuels.

While good-quality wood has a calorific value of 4.4 kW/kg (15% moisture, after about 18 months of seasoning), whereas that of pellets is around 4.9 kW/kg. To ensure good combustion, the pellets must be stored in a dry place and protected from dirt. Pellets are usually supplied in 15 kg bags, therefore, storing them is very convenient

Good quality pellets guarantee good combustion, thereby decreasing harmful emissions into the atmosphere.



15 Kg BAG OF PELLETS



The poorer the quality of the fuel, the more often the internal parts of the brazier and combustion chamber must be cleaned.

The main quality certifications for pellets currently available on the European market guarantee that the fuel complies with class A1/A2 according to ISO 17225-2 (ex EN 14961). These certifications include, for example, **ENplus**, **DINplus**, **Ö-Norm M7135**, and specifically assure that the following characteristics are complied with:

- calorific value: 4.6 ÷ 5.3 kWh/kg.
- Water content: ≤ 10% of the weight.
- Percentage of ash: max 1.2% of the weight (A1 less than 0.7%).
- Diameter: 6±1/8±1 mm.
- Length: 3÷40 mm.
- Content: 100% untreated wood without the addition of binding agents (max 5% bark).
- Packaging: in sacks made from ecologically compatible or biologically decomposing material.



The company strongly recommends using certified fuel for its products (ENplus, DINplus, Ö-Norm M7135). Poor quality pellets or others that do not comply with the characteristics specified previously may compromise the operation of your product and can therefore make the warranty and product liability invalid.

2-INSTALLATION

FOREWORD

The installation position must be chosen according to the room, smoke extraction system and flue. Check with local authorities whether there are any restrictive regulations in force regarding the combustion air inlet, the smoke outlet system, the flue or the chimney pot. The manufacturer declines all responsibility in the event of installations that do not comply with the laws in force, incorrect room air exchange, electrical connection non-compliant with the standards and inappropriate use of the appliance. The installation must be carried out by a qualified technician, who must issue a declaration of conformity of the system to the purchaser and shall assume full responsibility for final installation and consequent good operation of the product.

In particular one must ensure that:

- there is a suitable combustion air inlet and smoke outlet in compliance with the type of product installed
- other stoves or devices installed do not cause negative pressure in the room where the product is installed (for sealed appliances only, a maximum of 15 Pa of negative pressure in the room is allowed)
- when the product is switched on there is no reflux of smoke in the room
- smoke extraction takes place in full safety (sizing, smoke seal, distances from flammable materials..).

We especially recommend checking the data plates of the flue for the safety distances that must be observed in the presence of combustible materials and the type of insulating material to be used. These indications must be followed strictly to prevent serious harm to people and to the integrity of the home. Installation of the appliance must ensure easy access to clean the appliance itself, the smoke outlet pipes and the flue. **It is forbidden to install the stove in rooms with a fire hazard. Installation in studio flats, bedrooms and bathrooms is only permitted with sealed or closed appliances equipped with suitable combustion air ducting directly outside. Always maintain adequate distance and protection in order to prevent the product from coming into contact with water.**

In the event there are several appliances installed, the external air inlet must be sized accordingly.

MINIMUM DISTANCES

It is recommended to install the stove detached from any walls and/or furniture, with a minimum clearance to allow effective aeration of the appliance and a good distribution of heat in the room. Comply with the distances from flammable or heat-sensitive objects (sofas, furniture, wood panelling, etc.) as specified below. The frontal distance from flammable materials must be at least as specified in the product's technical data table.

If particularly delicate objects are present, such as furniture, curtains or sofas, increase the stove distance accordingly.



If the floor is made of wood, it is recommended to fit a floor protection sheet in compliance with the standards in force in the country of installation.

	Non-flammable walls	Flammable walls
FRESIA 70 AIR 9 S1	A = mm B = mm	A = 100 + 30 (INSULATION) mm B = 50 + 30 (INSULATION) mm

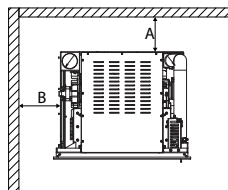

If the floor is made of combustible material, it is recommended to use a protection made of non-combustible material (steel, glass...) that also protects the front from any falling combusted material during cleaning operations.

The appliance must be installed on a floor with adequate load capacity.

If the existing construction does not meet this requirement, appropriate measures must be taken (for example a load distribution plate).

2-INSTALLATION

FOREWORD

The Flue chapter has been drawn up with reference to the provisions of European Standards (EN13384 - EN1443 - EN1856 - EN1457). The chapter provides indications for installing an efficient and correct flue but is under no circumstances to substitute the regulations in force, which the qualified manufacturer must be in possession of. Check with local authorities whether there are any restrictive regulations in force regarding the combustion air intake, the smoke outlet system, the flue or the chimney pot. The Company declines all liability relating to the poor functioning of the stove if this is due to the use of an insufficiently sized flue in violation of the standards in force.

FLUE

The flue or chimney is of great importance for proper operation of a solid fuel-burning heating appliance with forced draught, as modern heating appliances have high efficiency with cooler flue gasses and consequently less draught, it is therefore crucial for the flue to be built up to standard and always kept in perfect working order. A flue for a pellet/wood fuelled appliance must be at least category T400 (or greater if the appliance requires so) and resistant to soot fires. Smoke must be extracted through a single flue made of insulated steel (A) or an existing flue that complies with the intended use (B).

A simple air shaft made of cement must be suitably lined. In both solutions there must be an inspection cap (AT) and/or inspection hatch (AP) - FIG.1.

It is prohibited to connect more than one wood/pellet (*) or any other type of appliance (cowl vents ...) to the same flue.

(*) unless there are national derogations (for instance in Germany), which under suitable conditions allow for the installation of several appliances in the same fireplace. In any case, strictly follow the product/installation requirements of the relative regulations/legislation in force in that country

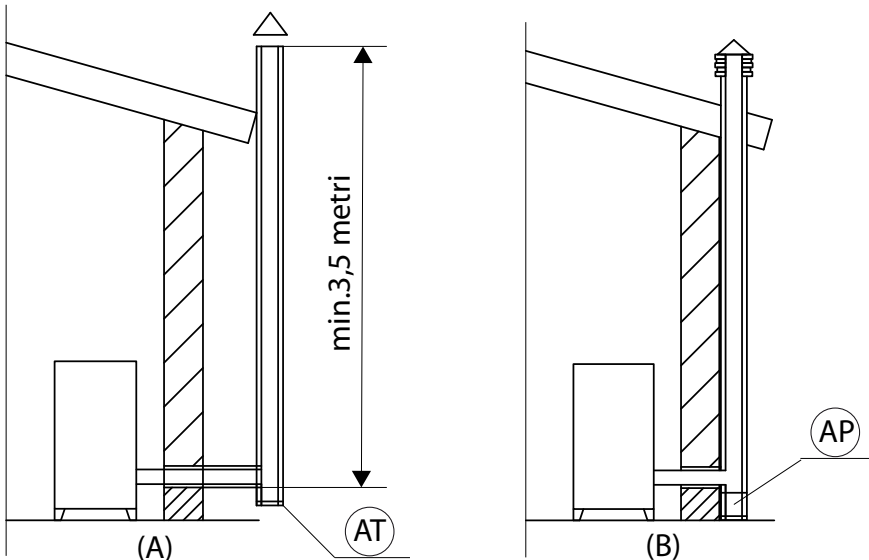

FIGURE 1 - FLUE

2-INSTALLATION

TECHNICAL SPECIFICATIONS

Have the efficiency of the flue checked by an authorised technician.

The flue must be sealed against flue gasses, in a vertical direction without narrowing, be made with materials impermeable to smoke, condensation, thermally insulated and suitable to resist normal mechanical stress over time (we recommend fireplaces made of A/316 or refractory material with insulated round section double chamber). It must be suitably insulated externally to avoid condensation and reduce smoke cooling. It must be separated from combustible or easily flammable materials via an air gap or insulating materials: check the distance specified by the chimney manufacturer according to EN1443. The chimney opening must be in the same room as the appliance, or at most in the adjoining room, and have a soot and condensation collection chamber beneath the opening, and be accessible via a sealed metal hatch.

FLAT ROOF

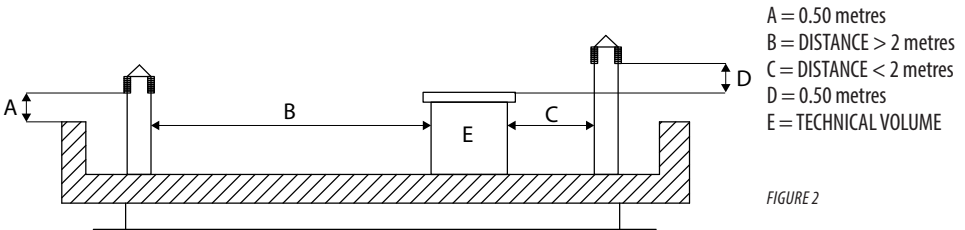

- A = 0.50 metres
- B = DISTANCE > 2 metres
- C = DISTANCE < 2 metres
- D = 0.50 metres
- E = TECHNICAL VOLUME

FIGURE 2

ROOF AT 15°

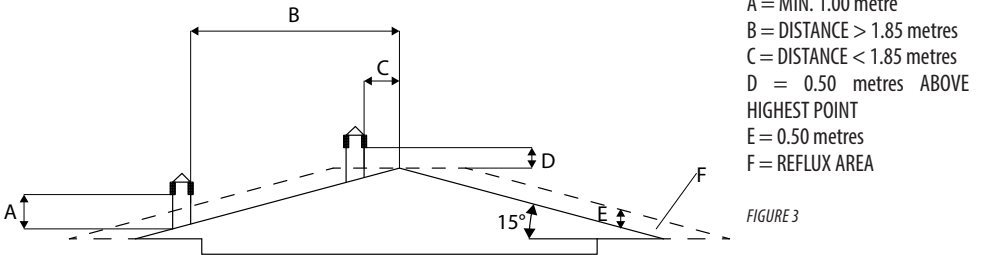

- A = MIN. 1.00 metre
- B = DISTANCE > 1.85 metres
- C = DISTANCE < 1.85 metres
- D = 0.50 metres ABOVE HIGHEST POINT
- E = 0.50 metres
- F = REFLUX AREA

FIGURE 3

ROOF AT 30°

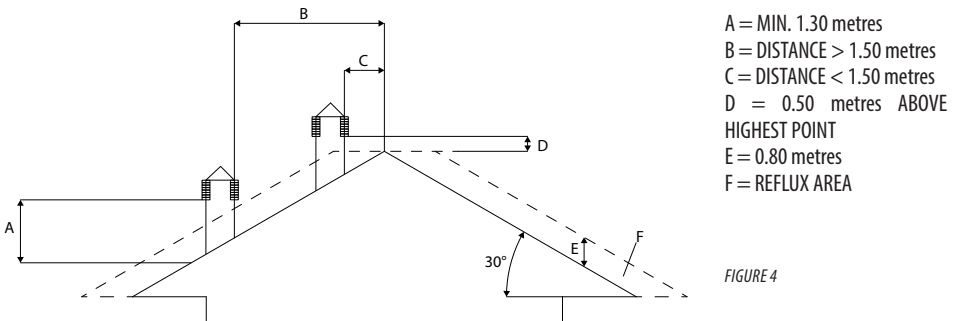

- A = MIN. 1.30 metres
- B = DISTANCE > 1.50 metres
- C = DISTANCE < 1.50 metres
- D = 0.50 metres ABOVE HIGHEST POINT
- E = 0.80 metres
- F = REFLUX AREA

FIGURE 4

2-INSTALLATION

ROOF AT 60°

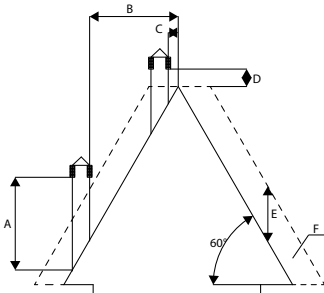

FIGURE 5

- A = MIN. 2.60 metres
- B = DISTANCE > 1.20 metres
- C = DISTANCE < 1.20 metres
- D = 0.50 metres ABOVE HIGHEST POINT
- E = 2.10 metres
- F = REFLUX AREA

ROOF AT 45°

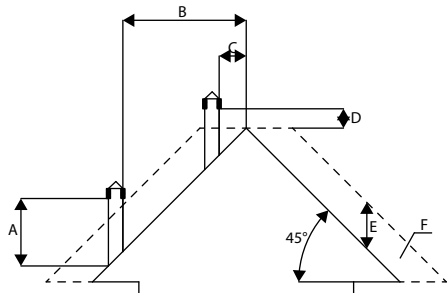

FIGURE 6

- A = MIN. 2.00 metres
- B = DISTANCE > 1.30 metres
- C = DISTANCE < 1.30 metres
- D = 0.50 metres ABOVE HIGHEST POINT
- E = 1.50 metres
- F = REFLUX AREA

SIZING

The negative pressure (draught) of a flue also depends on its height. Check the negative pressure with the values indicated in the technical specifications. The minimum height of the chimney is 3.5 metres.

The interior cross-section of the flue can be round (best), square or rectangular (the ratio between the internal sides must be ≤ 1.5) with the sides joined with a minimum radius of 20 mm. The dimension of the cross-section must be **minimum $\varnothing 100\text{mm}$** .

The cross-sections/lengths of the chimneys shown in the technical data tables are indications for correct installation. Any alternative configurations must be correctly sized in accordance with the general method of calculation of UNI EN13384-1 or other proven efficiency methods.

Some examples of flues available on the market are provided below:

AISI 316 steel chimney with double chamber insulated with ceramic fibre or equivalent resistant up to 400°C.

Refractory chimney with double insulated chamber and external lightweight concrete cladding with cellular material such as clay.

Traditional square-section clay chimney with insulating empty inserts.

Avoid products with an internal rectangular section where the larger side is 1.5 times the smaller side (e.g. 20x40 or 15x30).

EXCELLENT

GOOD

POOR

VERY POOR

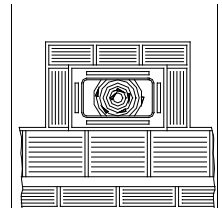
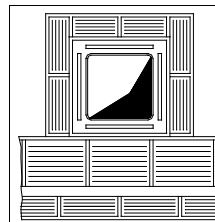
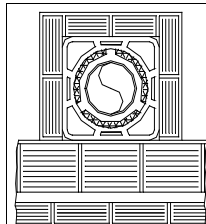
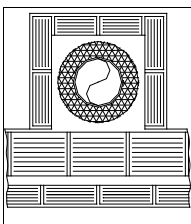

2-INSTALLATION

MAINTENANCE

The flue must be kept clean, since the deposit of soot or unburnt oils reduces the cross-section, blocking the draught and thus compromising the efficient operation of the stove and, if large build-ups accumulate, can catch fire. The flue and chimney pot must be cleaned and checked by a qualified chimney sweep at least once a year. Once the inspection/maintenance has been performed, request a written report that the system is safe.

Failure to perform cleaning jeopardises the system's safety.

CHIMNEY POT

The chimney pot is a crucial element for correct operation of the heating appliance: we recommend a wind proof chimney pot (A), see Figure 7.

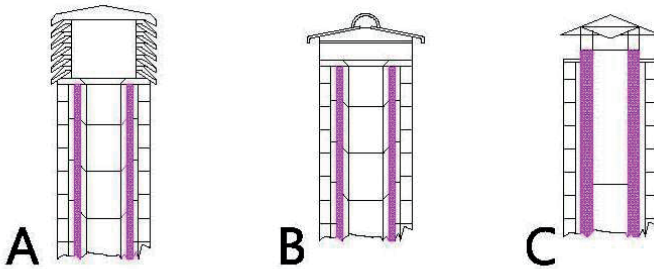

The area of the opening for smoke extraction must be at least double the cross-section of the flue/lined system, and arranged so that smoke outlet is ensured even in the presence of strong wind. The chimney pot must prevent rain, snow or animals from entering the chimney. The height of outflow into the atmosphere must be beyond the reflux area caused by the shape of the roof or any nearby obstacles (see Figures 2-3-4-5-6).

FIGURE 7

CHIMNEY COMPONENTS

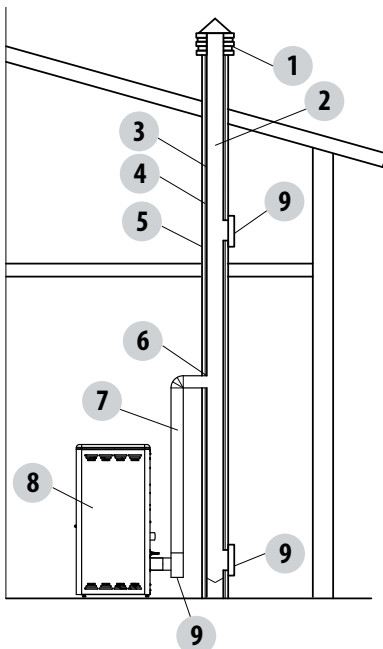

- KEY:
- (1) CHIMNEY POT
 - (2) REFLUX CHANNEL
 - (3) SMOKE DUCT
 - (4) THERMAL INSULATION
 - (5) OUTSIDE WALL
 - (6) CHIMNEY FITTING
 - (7) SMOKE DUCT
 - (8) HEAT GENERATOR
 - (9) INSPECTION DOOR

FIGURE 8

2-INSTALLATION

EXTERNAL AIR INLET

It is mandatory to provide an adequate external air inlet that supplies the combustion air required for the product to work properly. The flow of air between the outside and the installation room may be direct, through an inlet in an external wall of the room (preferable solution see Figure 9 a), or indirect, via air intake from adjoining rooms and connecting permanently with the installation room (see Figure 9 b). Adjoining areas may not include sleeping areas, bathrooms, garages or general areas with a fire hazard. During installation it is required to check the minimum clearances required to draw air from outside. Take into account the presence of doors and windows that may interfere with the proper flow of air to the stove (see diagram below).

The air intake must have a minimum total net area of 80 cm²: the surface must be increased accordingly if other active generators (for example: electric fan for stale air extraction, kitchen hood, other stoves, etc.), which may cause depression in the room, are present. Make sure that, with all appliances on, the pressure drop between the room and the outside does not exceed the value of 4 Pa (also for Oyster appliances if the combustion air has not been suitably ducted outside). If required, increase the intake section of the air inlet, which must be made at floor level and always protected with a bird-proof outer protection grid and in such a way that it cannot be obstructed by any object.

FIGURE 9 A - DIRECTLY FROM OUTSIDE

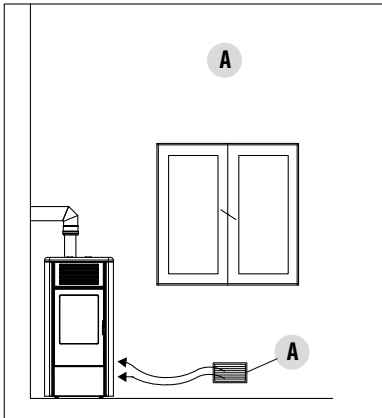
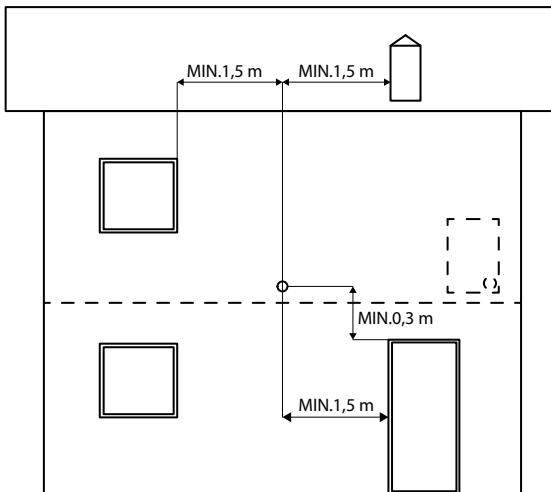
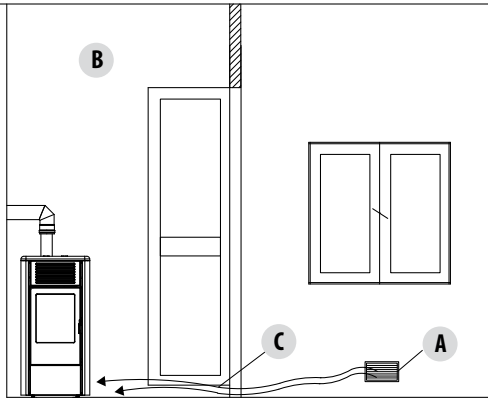

FIGURE 9 B - INDIRECTLY FROM THE ADJACENT ROOM



A=AIR INLET
B=ROOM TO BE VENTILATED
C=INCREASE OF THE GAP UNDER THE DOOR

It is possible to connect the air required for combustion directly to the outside air inlet, by using a pipe of at least Ø50mm, with maximum length of 3 linear metres. Each pipe bend must be considered equivalent to a linear metre. To attach the pipe see the rear of the stove.

For stoves installed in studio flats, bedrooms and bathrooms (where allowed), it is mandatory to connect the combustion air outside. Specifically for sealed stoves the connection must be sealed in order not to compromise the overall sealing of the system.

FIGURE 10

2-INSTALLATION

DISTANCE (metres)	The air inlet must be at a distance of:	
1.5 m	BELOW	Doors, windows, smoke outlets, cavities,
1.5 m	HORIZONTALLY	Doors, windows, smoke outlets, cavities,
0.3 m	ABOVE	Doors, windows, smoke outlets, cavities,
1.5 m	AT A DISTANCE	from smoke outlet

CONNECTION TO THE FLUE

The connection between the flue and the appliance must be via a smoke duct compliant to EN 1856-2. The connecting section must extend no more than 4 m horizontally, with a minimum slope of 3% and with a maximum of 3 90° bends (accessible for inspection - do not count the T fitting at the appliance outlet).

The diameter of the smoke duct must be equal to or greater than that of the outlet of the appliance (\varnothing 80 mm).

TYPE OF SYSTEM	SMOKE DUCT
Minimum vertical length	1.5 metres
Maximum length (with 1 accessible 90° bend)	6.5 metres
Maximum length (with 3 accessible 90° bends)	4.5 metres
Maximum number of accessible 90° bends	3
Horizontal sections (minimum slope 3%)	4 metres

Use smoke ducts with a diameter of 80mm or 100mm depending on the type of system, with silicone gaskets or similar gaskets that can withstand the high operating temperatures of the appliance (min. T200 class P1). **The use of flexible metal hoses made of fibre cement or aluminium is forbidden. For direction changes, we always recommend the use of a T fitting with an inspection cap allowing easy access for cleaning the tubes.** Always ensure that the inspection cap is put back in place and sealed hermetically with the relevant seal intact after cleaning.

It is prohibited to connect more than one appliance to the same smoke duct, or the discharge from hoods above it. It is forbidden to extract the combustion products directly through the wall, whether into indoor spaces or outdoors.

The smoke duct must be at a minimum distance of 400 mm from flammable or heat-sensitive structures.

2-INSTALLATION

EXAMPLES OF CORRECT INSTALLATION

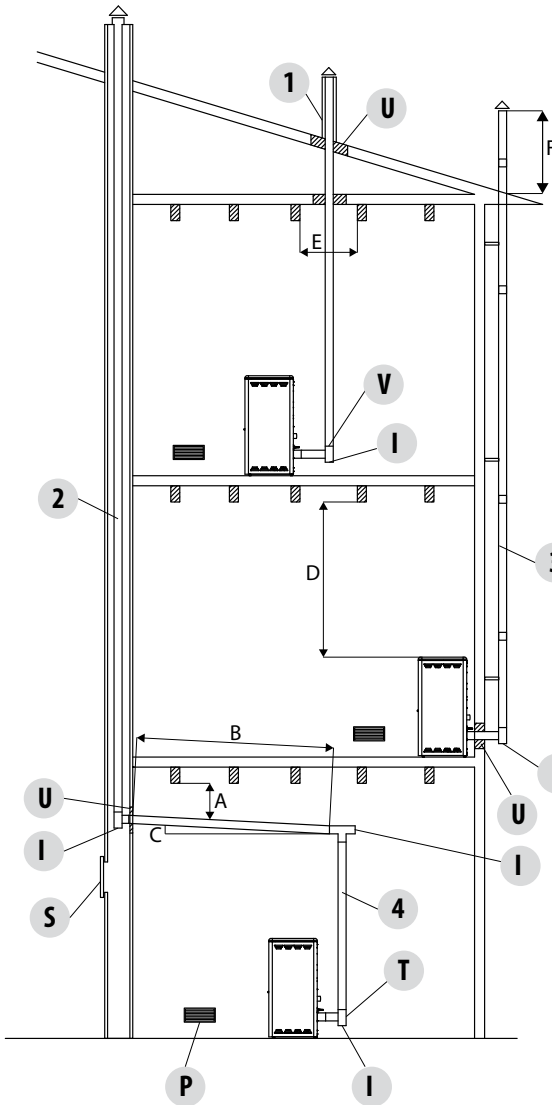

1. Installation of $\varnothing 120\text{mm}$ flue with hole for the passage of the pipe increased by:
 minimum 100mm around the pipe if next to non flammable parts such as cement, brick, etc.; or
 minimum 300mm around the pipe (or as required by plate data) if next to flammable parts such as wood etc.
 In both cases, install suitable insulation between the flue and the ceiling.

Always check and comply with the plate data of the flue, specifically the minimum safety distances from combustible materials.

The previous rules also apply for holes made in walls.

2. Old flue, minimum pipe $\varnothing 100\text{mm}$ with the inclusion of an external access door for chimney cleaning.

3. External flue made of insulated stainless steel pipes, i.e. with double walls minimum $\varnothing 100\text{mm}$: all securely mounted on the wall. With windproof chimney pot. See fig. 7 type A.

4. Ducting system using T fittings that allow easy access for cleaning without having to remove the pipes

FIGURE 11

U = INSULATION
 V = ANY REDUCTION FROM 100 TO 80 MM
 I = INSPECTION CAP
 S = INSPECTION ACCESS PANEL
 P = AIR INLET
 T = T FITTING WITH INSPECTION CAP

A = MINIMUM 40 MM
 B = MAXIMUM 4 M
 C = MINIMUM 3°
 D = MINIMUM 400 MM
 E = HOLE DIAMETER
 F = SEE FIG.2-3-4-5-6

3-DRAWINGS AND TECHNICAL SPECIFICATIONS

DRAWINGS AND CHARACTERISTICS FRESIA 70 AIR 9 S1 DIMENSIONS (dimensions in mm)

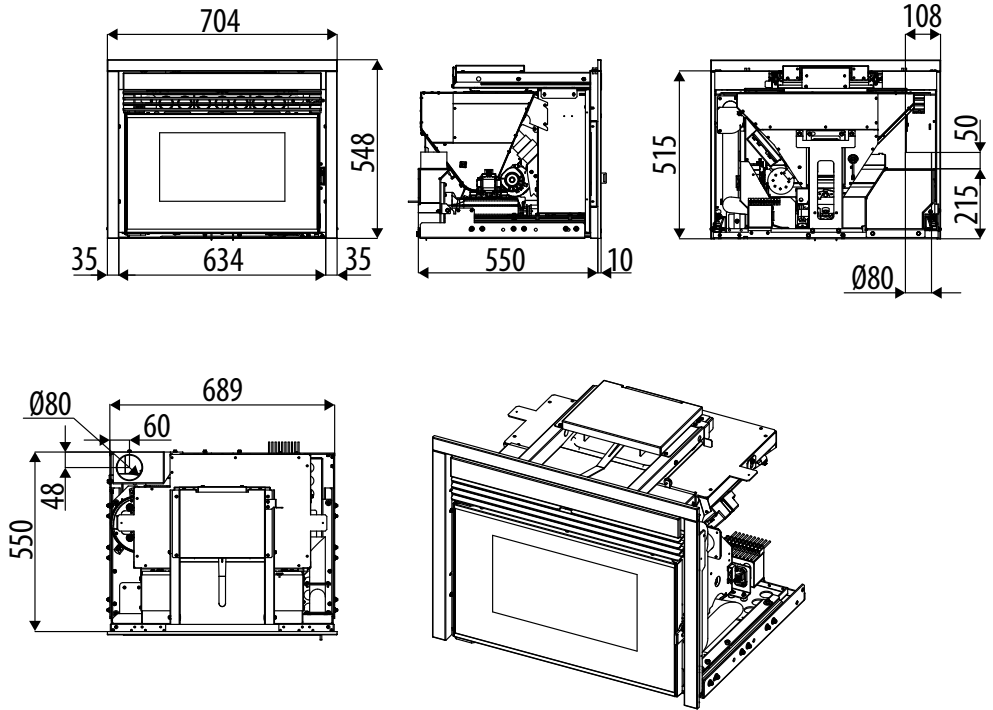

3-DRAWINGS AND TECHNICAL SPECIFICATIONS

TECHNICAL SPECIFICATIONS	FRESIA 70 AIR 9 S1
Energy Efficiency Class	A+
Nominal output power	8.8 kW (7568 kcal/h)
Minimum power output	2.5 kW (2150 kcal/h)
Efficiency at Max	90.6%
Efficiency at Min	94.1%
Temperature of exhaust smoke at Max	188 °C
Temperature of exhaust smoke at Min	93°C
Particulate / OGC / Nox (13%O ₂)	17 mg/Nm ³ - 2 mg/Nm ³ - 130 mg/Nm ³
CO at 13% O ₂ at Min and at Max	0.026 – 0.011%
CO ₂ at Min and at Max	8.6% - 13.2%
Recommended draught at Max*** power	0.10 mbar - 10 Pa***
Minimum draught allowed at minimum power	0.05 mbar - 5 Pa
Smoke mass	5.0 g/sec
Tank capacity	20 litres
Type of pellet fuel	Pellet diameter 6 mm and size 3 - 40 mm
Pellet hourly consumption	Min ~ 0.6 kg/h* - Max ~ 2.0 kg/h*
Autonomy	At min ~ 21 h* - At max ~ 6 h*
Heatable volume m ³	189/40 – 216/35 – 252/30 **
Combustion air inlet	Ø 50 mm
Smoke outlet	Ø 80 mm
Air inlet	80 cm ²
Rated electrical power (EN 60335-1)	75 W (Max 306 W)
Supply voltage and frequency	230 Volt / 50 Hz
Net weight	135 kg
Weight with packaging	145 kg
Distance from combustible material (back/side/under)	100+30 (insulation) mm/50+30 (insulation) mm/non combustible material
Distance from combustible material (ceiling/front)	300+30 (insulation) mm/1000 mm

* Data that may vary depending on the type of pellets used

** Volume that can be heated, according to the power requirement per m³ (respectively 40-35-30 Kcal/h per m³)

***Value recommended by the manufacturer (non-binding) for optimal product operation

Tested according to EN 14785 in accordance with European regulation for Construction Products (EU 305/2011).

4-UNPACKING

PREPARATION AND UNPACKING

The product is supplied in a single package.

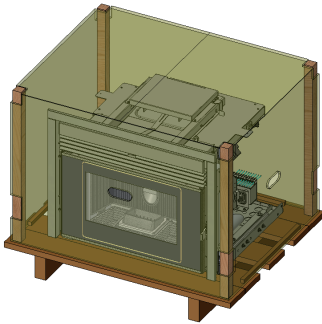

Open the package, remove any straps, cardboard and polystyrene and take the appliance off the pallet.

To remove the product from the pallet you must extract the movable part of the insert and take out the four Phillips screws securing it to the pallet. Once the insert has been extracted, before removing the screws, it is advisable to place a support "A" under the movable part of the insert so as to work safely.

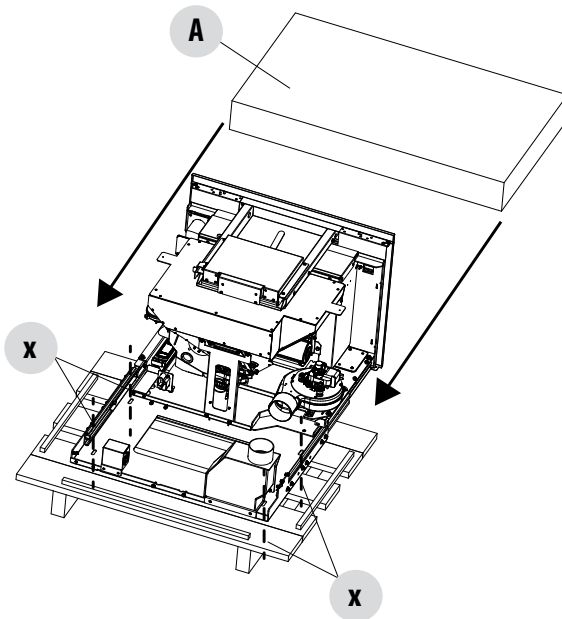

The appliance must always be carried upright, taking care with its moving parts. Pay particular attention to the door and its glass, protecting them from mechanical impacts that would compromise their integrity.

The product must always be handled with care. If possible unpack the product near the place of installation. The packaging materials are neither toxic nor harmful, therefore no particular disposal measures are required. Therefore, the end user is responsible for product storage, disposal or potential recycling in compliance with the relative applicable laws in force.

If the product must be connected to an exhaust pipe that goes through the rear wall (to enter the flue), make sure not to force it in.

5-OVERALL DIMENSIONS

FRESIA 70 AIR 9 S1

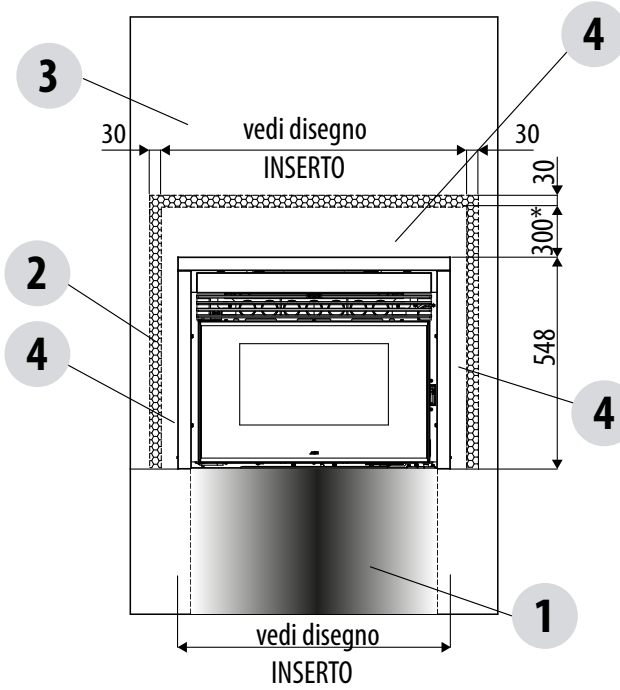

FRESIA 70 AIR 9 S1 (Pianta)

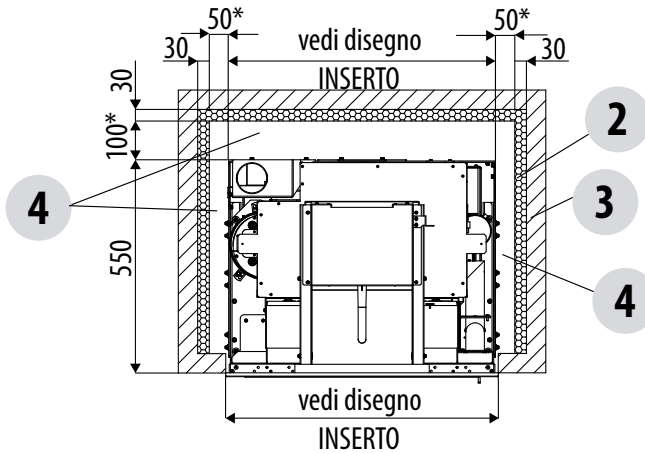

1	INSERT SUPPORT (existing or new)	3	WALL
2	INSULATION	4	SAFETY DISTANCE FROM COMBUSTIBLE MATERIAL*

5-OVERALL DIMENSIONS

EXAMPLE OF PLACEMENT AT A 90° ANGLE

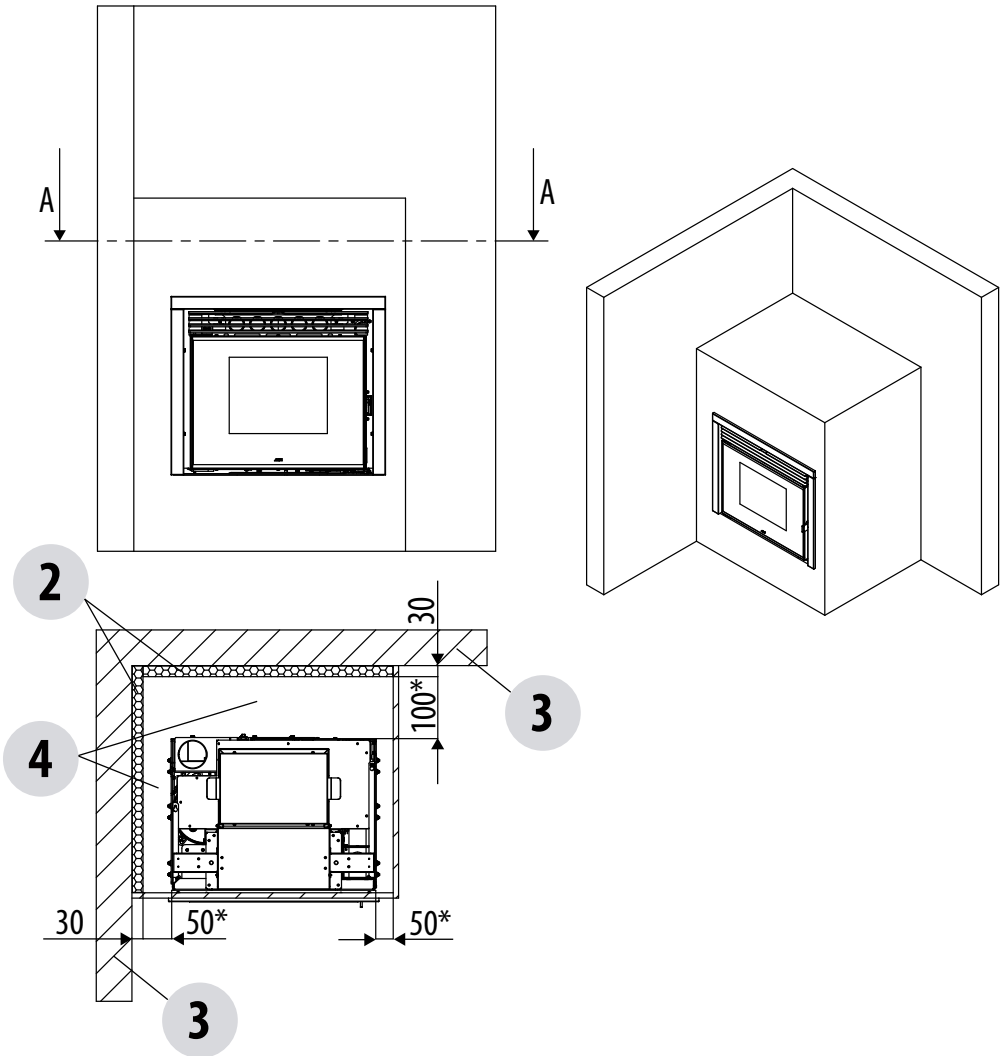

5-OVERALL DIMENSIONS

EXAMPLE OF PLACEMENT AT A 45° ANGLE

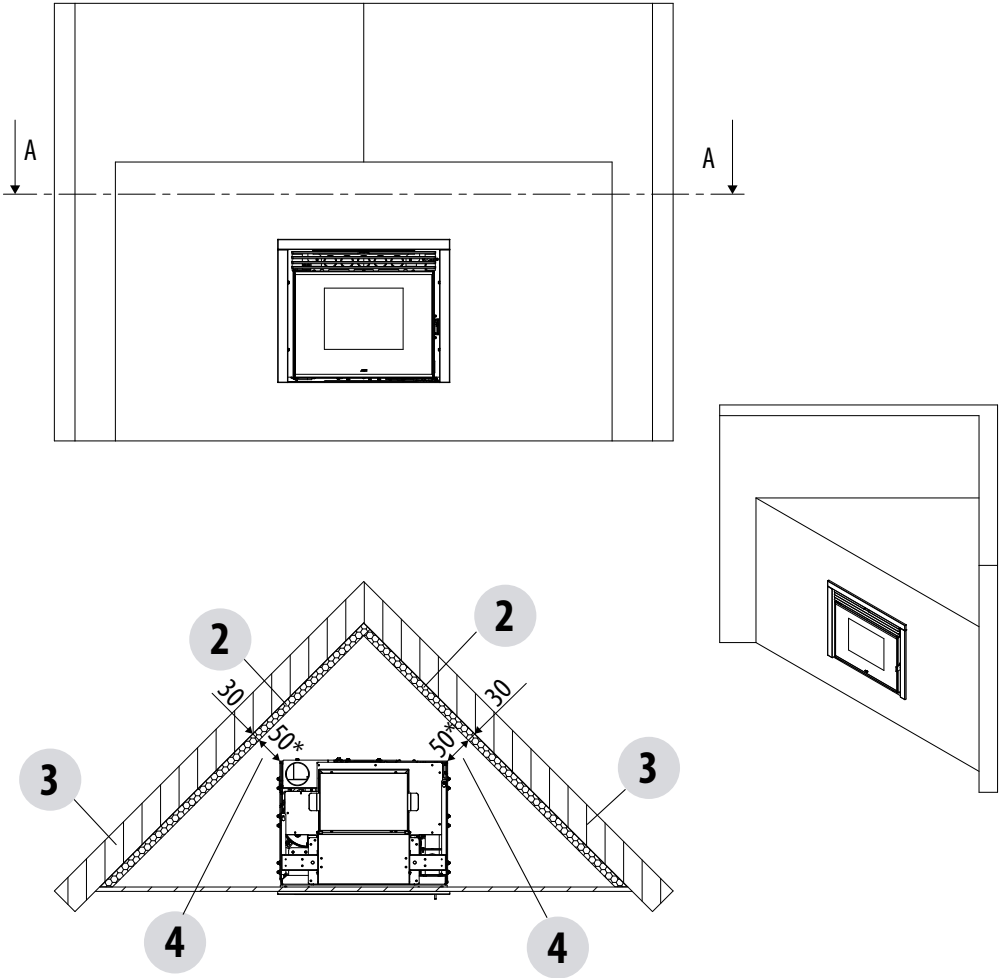

6-PRELIMINARY OPERATIONS

COMBUSTION AIR

During operation a certain amount of air is drawn from the room in which the product is installed and this air must be supplemented through an external air inlet.

The combustion air "B" in this product is autonomously drawn directly from the front grille, however, the user can have the air drawn from outside by connecting pipe "A" to an optional air kit (see details on the next pages).

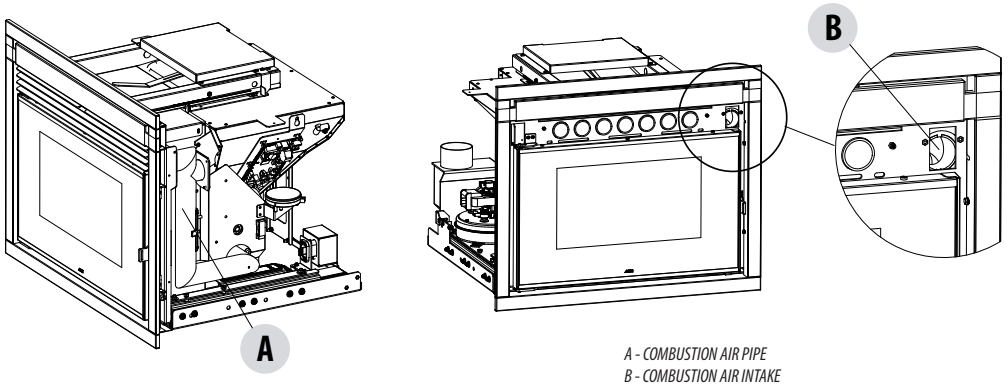

ATTENTION! It is forbidden, in secondary use heating appliances, to use the product at maximum power for more than 2/3 hours.

Improper use of the product is borne by the user and relieves the manufacturer of any civil and criminal liability.

CONNECTION OF THE SMOKE OUTLET DUCT

When making the hole for the passage of the smoke outlet pipe, it is necessary to take into account the possible presence of flammable materials. If the hole has to be made in a wall made of wood or other thermolabile material, THE INSTALLER MUST first set up the relative wall fitting (diameter 13 cm minimum) and insulate the pipe the product passes with appropriate insulating material (thick. (1.3 - 5 cm with minimum heat conductivity of 0.07 W/m²K).

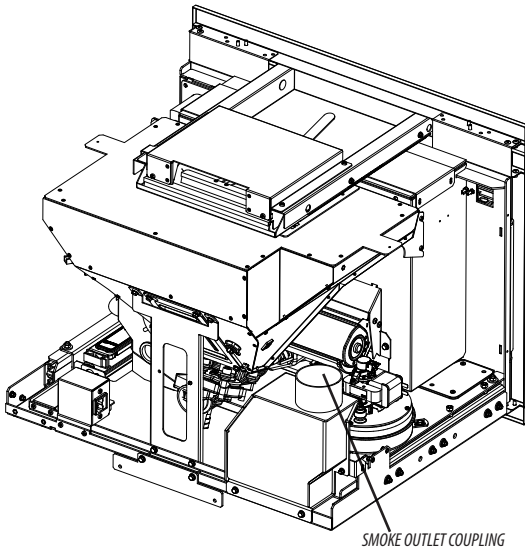

The same minimum distance must be applied if the pipe of the product must pass through vertical or horizontal sections near the thermolabile wall. It is recommended to use an insulated double-wall pipe in external sections in order to prevent condensation from forming. The combustion chamber works at negative pressure.

6-PRELIMINARY OPERATIONS

PRELIMINARY STEPS

Proceed as follows to release the fixed part of the insert:

- remove the two nuts "d" and the two washers "r" from the right and left of the insert

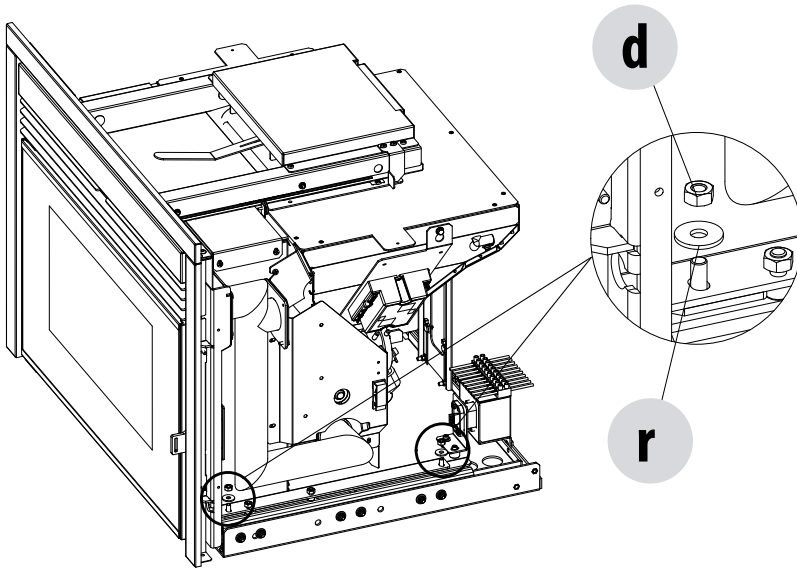

to make it easier to hold, take the two optional handles "M" and fasten them to the insert

- there are two nuts "u" on the insert to be removed, insert the handle "M" and put the two nuts "u" back in place
- the handles "M" are now fastened on the insert. Hold the two handles "M" and lift the insert

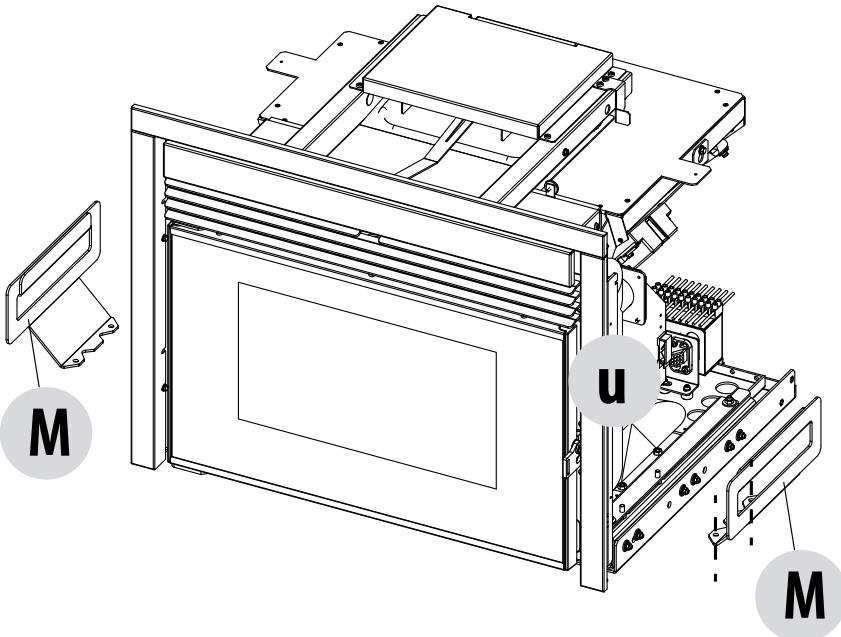

6-PRELIMINARY OPERATIONS

- the fixed part "A" is now free and you can fasten it onto the optional support or on an existing surface (as explained in the next pages)

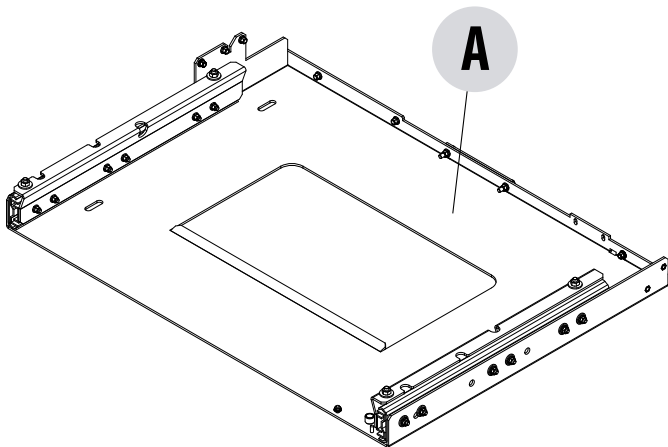
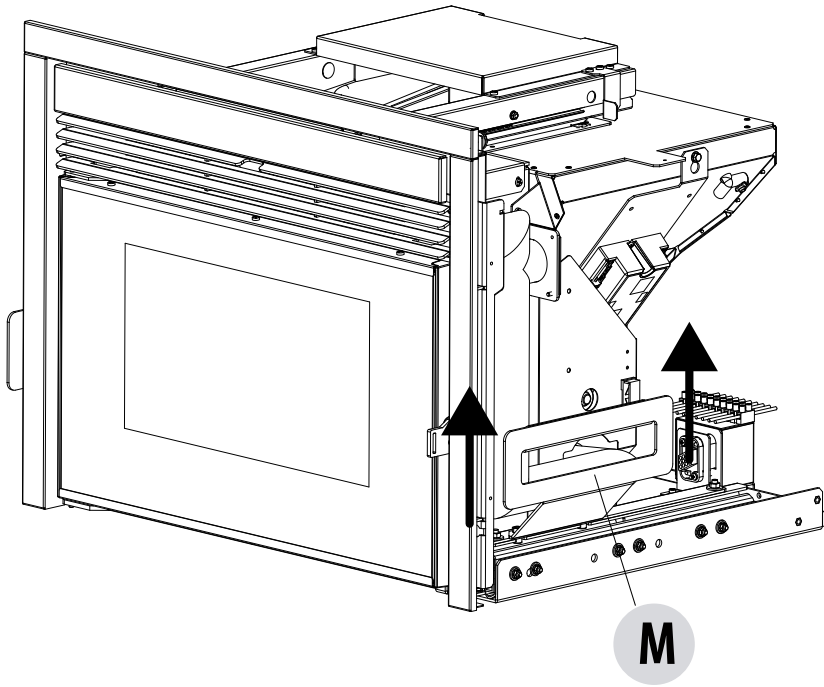

7-TYPE OF FASTENING

HOW TO FASTEN THE INSERT

It is **mandatory** to anchor the product to a surface since, during annual maintenance operations by the authorised technician, or when the fuel is loaded, the combustion chamber may be extracted from its seat with the aid of two retractable guides.

The product can be anchored to an existing surface (which must have certain characteristics) or it can be fastened to the optional support.



Attention! The support surface of the insert must be completely flat.

Fastening to an existing surface - suggested characteristics

Installation data

The surface where the fixed part of the insert is to be fastened must be in R250 kg/cm² concrete, if the supporting is made of poor material, it is advisable to use a suitable slab for fastening.

We recommend using an anchor bolt with the following characteristics:

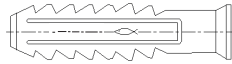

DIMENSIONS (TYPE)	DIAMETER	LENGTH
LH 10	10 mm	50 mm

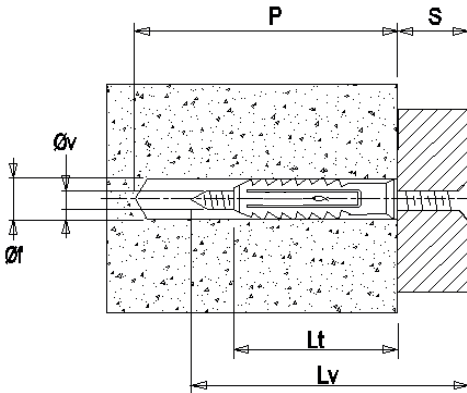

KEY

$L_v = L_t + S$ (Screw length)

L_t = Anchor bolt length

S = Maximum thickness of object to be fastened

$\varnothing f$ = drill bit diameter

P = Minimum hole depth

$\varnothing v$ = screw diameter

TYPE	L_t (anchor bolt length)	Screw $\varnothing V$ $\times L_v$	P (Minimum Hole depth)	$\varnothing f$ (drill bit diameter)	S (Max Object thickness)
LH 10	50 mm	8x60 mm	70 mm	10 mm	10 mm

7-TYPE OF FASTENING

Fastening to an existing surface

Key

POSITION	DESCRIPTION
A	FIXED INSERT PART
U	EXISTING SURFACE
t	ANCHOR BOLT (SEE PREVIOUS PAGE)
o	WASHERS

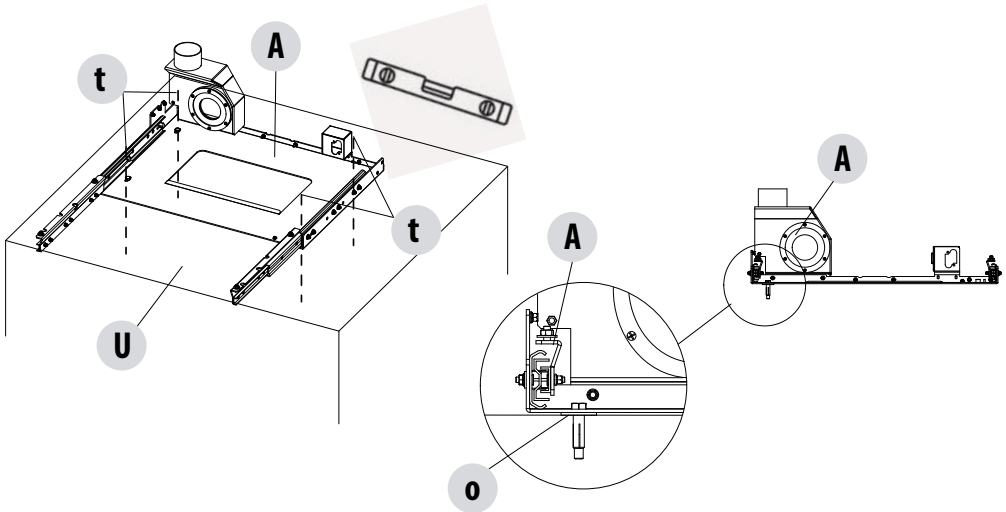

If installing on an existing surface, fitted with grille "G" (see next pages), it is strongly recommended to fasten it according to the diagram.

Place the 4 washers "o" (supplied) on the surface "U" and mount the fixed part "A" over them. Make sure everything is level.

7-TYPE OF FASTENING

Fastening to the horizontal support

Place the base in the desired position (after mounting it as explained in the instructions attached to the accessory) and adjust the height by using the feet (from a min. of 500 mm to a max. of 650 mm).

Make sure there is a power socket behind the pedestal so that the plug is accessible after the unit has been installed. Connect the smoke outlet and make the air inlets.

It is mandatory to fasten the support to the floor with anchor bolts and 8 mm diameter screws that will ensure stability of the product. Take the sliding base and fasten it with the support bracket. The support is already provided with the bracket "P" for other types of product.

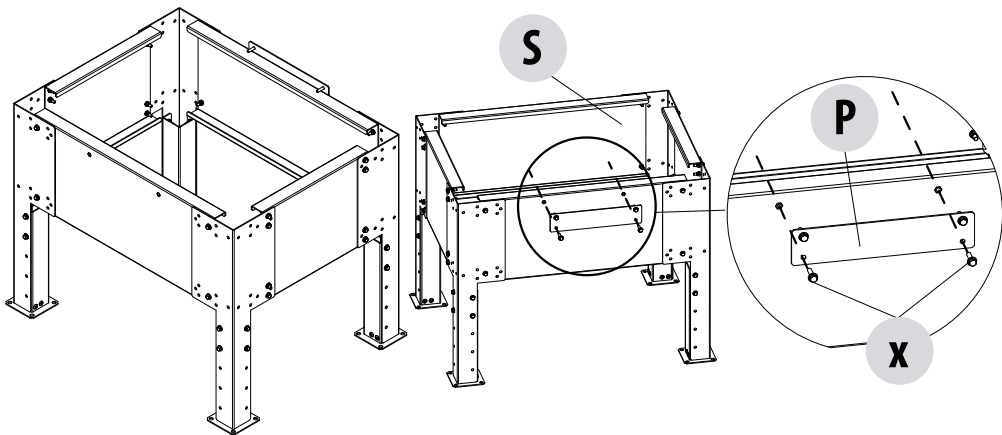

Do not mount the bracket "P" supplied in the support pack but use the one provided with the insert.

Take the movable part off the insert and connect the fixed part "A" to the support "S" with the bracket "T" and screws "k" provided.

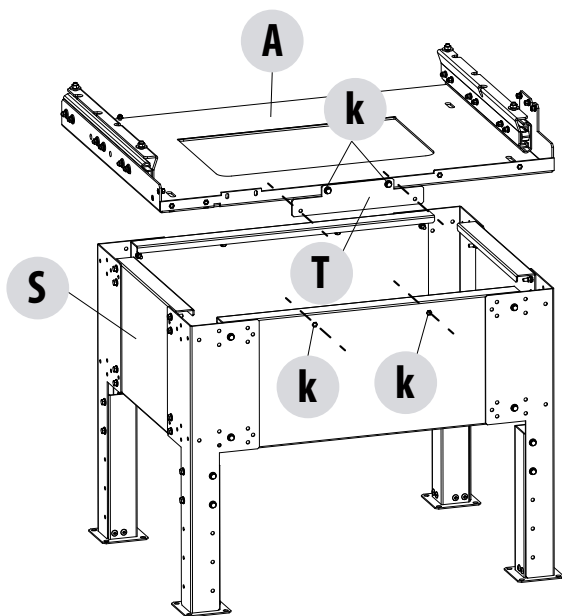

7-TYPE OF FASTENING

INSTALLING INSERT ON EXISTING CHIMNEY

AIR INTAKE GRILLE IN THE BEST POSITION

The best position for the air intake grille "G" is in the centre of the existing firebox with the measurements shown in the table.

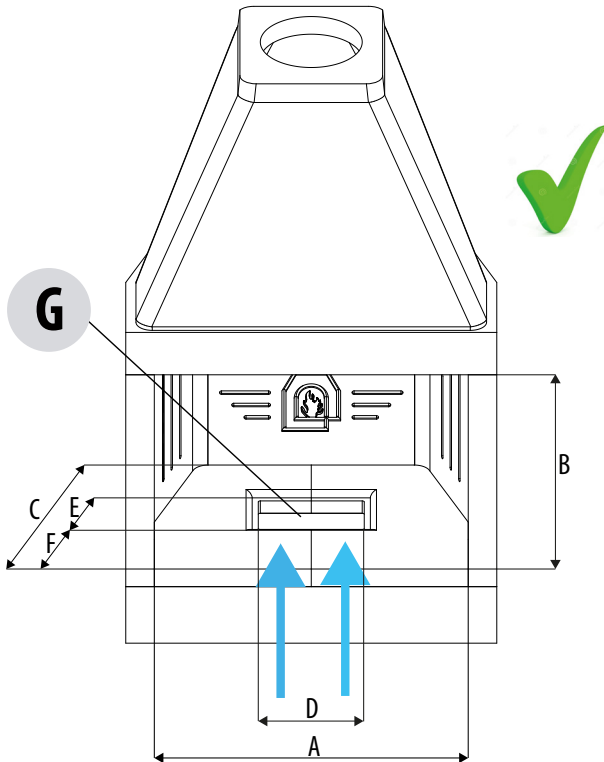

	FRESIA 70 AIR 9 S1
A	930
B	600
C	580
D	260
E	140
F	MIN 200
	MAX 250

G = AIR INTAKE GRILLE

7-TYPE OF FASTENING

AIR INTAKE GRILLE ON THE LEFT

If the position of the air intake grille "G" is on the left of the firebox, it needs to be changed and moved towards the centre of the firebox in the best position. The opening of the existing firebox must nevertheless have the measurements shown on the previous page.

POS.1 PIT H60 mm MIN.

POS.2 FILL IN THE SURFACE

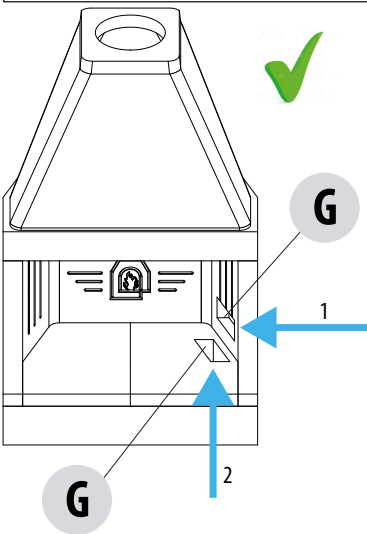
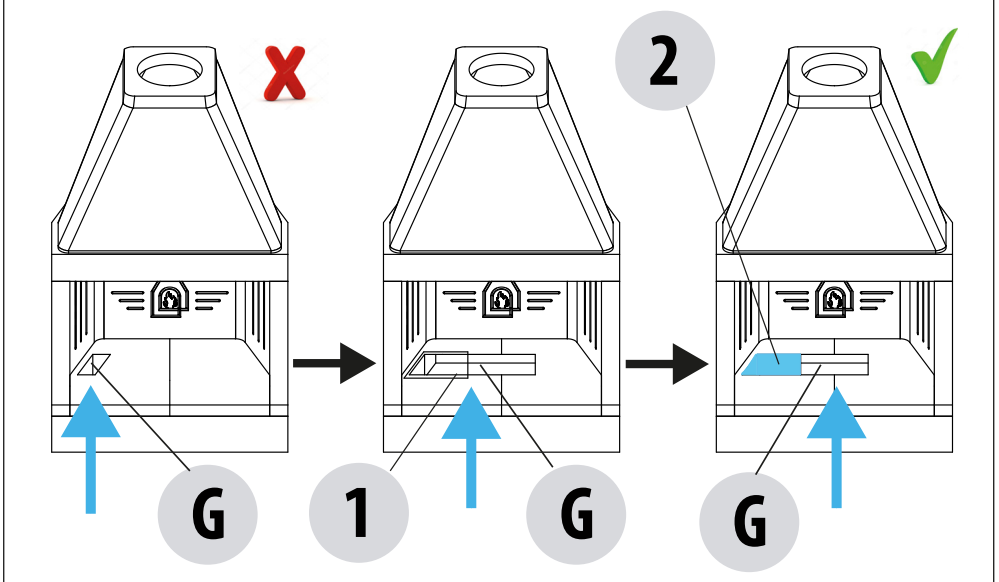

The opening for the air intake "G" can be on the bottom (2) or on the right side (1). In this case, make sure the fixed part of the insert does not cover the opening.

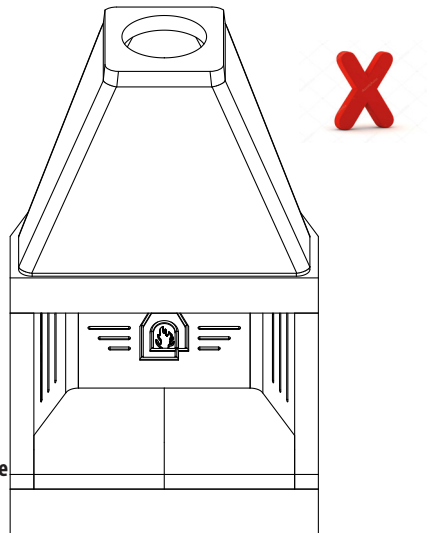

If the existing firebox does not have any air openings, you must use the "Feet kit" accessory (as shown on the next page).

7-TYPE OF FASTENING

FASTENING TO THE EXISTING FIREBOX WITHOUT AIR OPENINGS

If the existing firebox does not have any air openings (see next pages), you must use the "Feet kit" accessory (optional). Follow the procedure below to position it:

- After separating the fixed part "A" from the rest of the product (see instructions in "Preliminary steps" chapter), place the piece "A" on top of the base "S" respecting the positioning measurements.
- Mark where the four holes on base "A" are on base "S".
- Remove the part "A" and drill the holes on "S".
- Insert the anchor bolts "y" into the holes

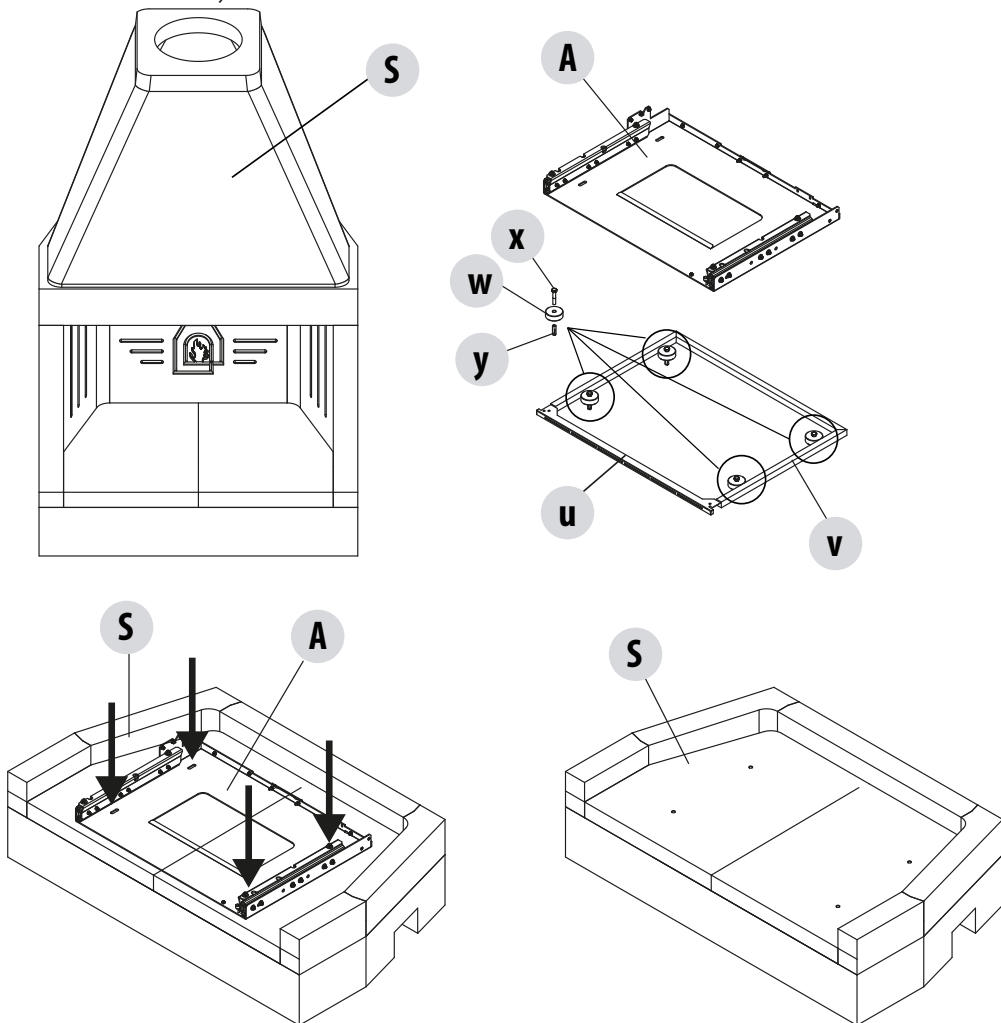

Attention! The piece "u" (see previous page) is to be mounted on the frame on three sides of the insert with the screws and nuts supplied in the kit.

7-TYPE OF FASTENING

- position the foot "W" on the surface "S" where the holes are
- pick the rubber strip "v" up, remove the adhesive film and fix it under the piece "A" cut to size flush with the outer perimeter of the part "A"
- Pick the piece "A" up with the rubber strip "v" stuck on it and place it on the feet "w"
- in the part above the piece "A" where the holes are, fasten it all together with the four screws "x" supplied

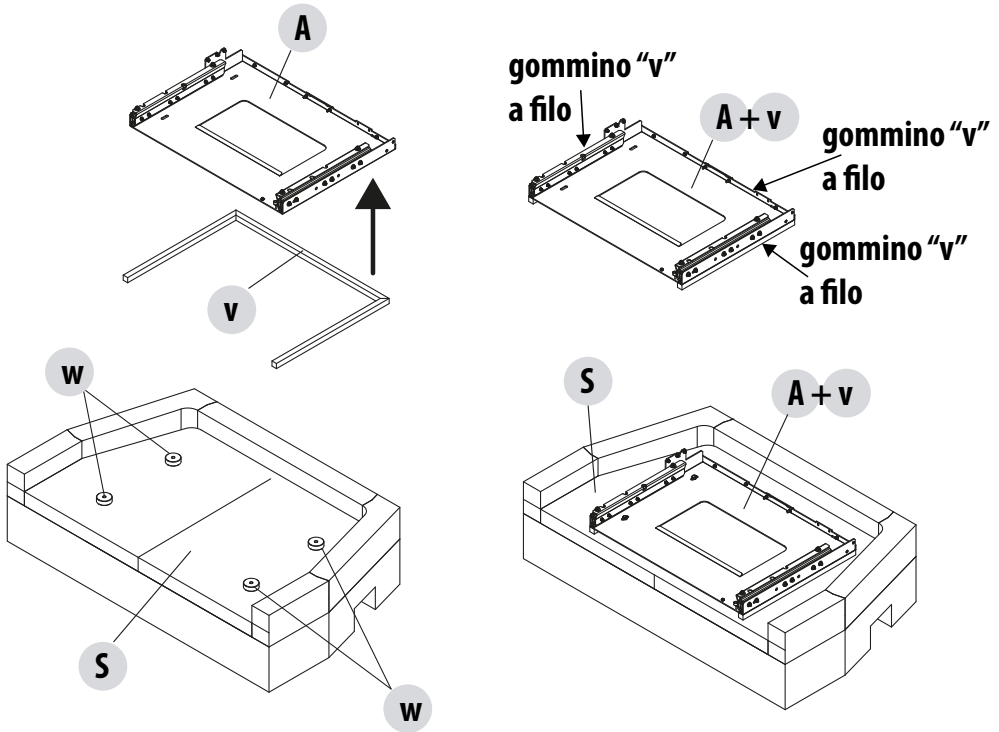

WALL HOLE TO POSITION INSERT

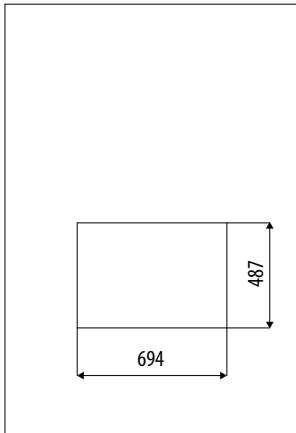

The hole to be drilled in the wall for the insert is 694*487 mm

8-ACCESSORIES

ACCESSORIES

COMBUSTION AIR KIT

The combustion air kit is used to withdraw combustion air from the outdoor environment.

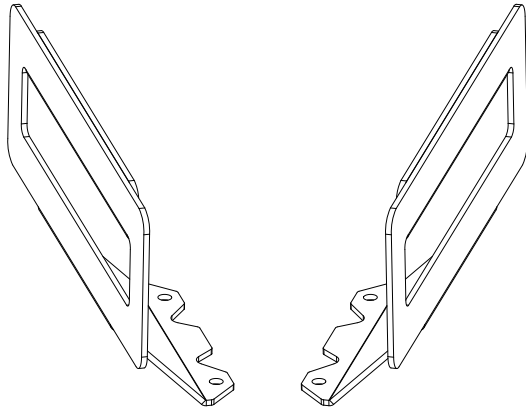
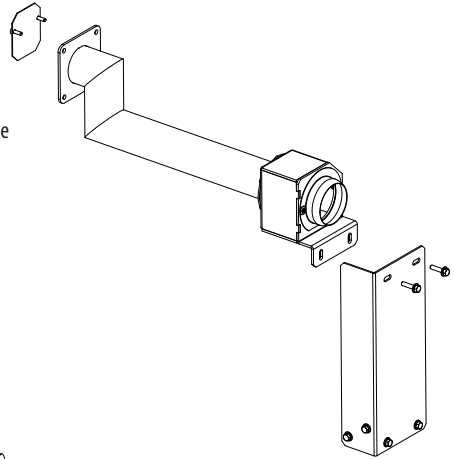

HANDLE KIT

The handle kit is used to handle the insert conveniently.

WI-FI KIT INSTALLATION (OPTIONAL)

Install the Wi-Fi kit (code 4016003), according to the indications in the specific manual, on the back or near the stove using the velcro supplied with the accessory.

Attention! The APP "WIFI Easy" is available in the Play Store for Android Smartphones and Tablets and in iTunes for iOS.



8-ACCESSORIES

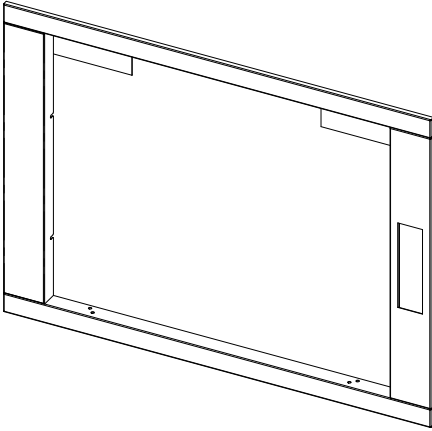

4-SIDED FRAME

Passé-partout board with option of inserting the control panel.

Support

Used to position the insert at the required height without using an existing surface.

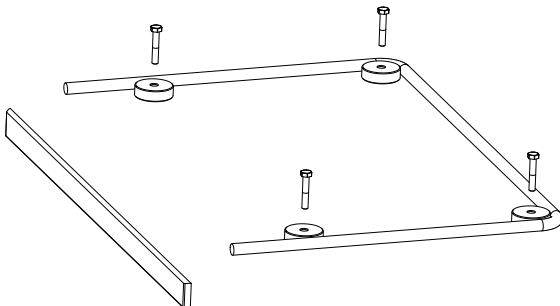
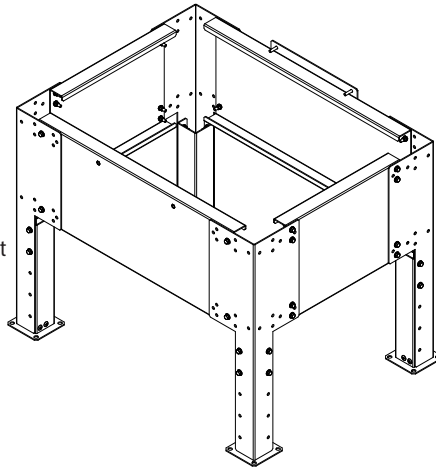

Feet kit

To be used if installing with an existing surface to allow the cooling air to flow correctly.

The kit consists of: a seal, 4 feet and relative screws and closing profile.

9-ASSEMBLING THE ACCESSORIES

ASSEMBLING COMBUSTION AIR KIT

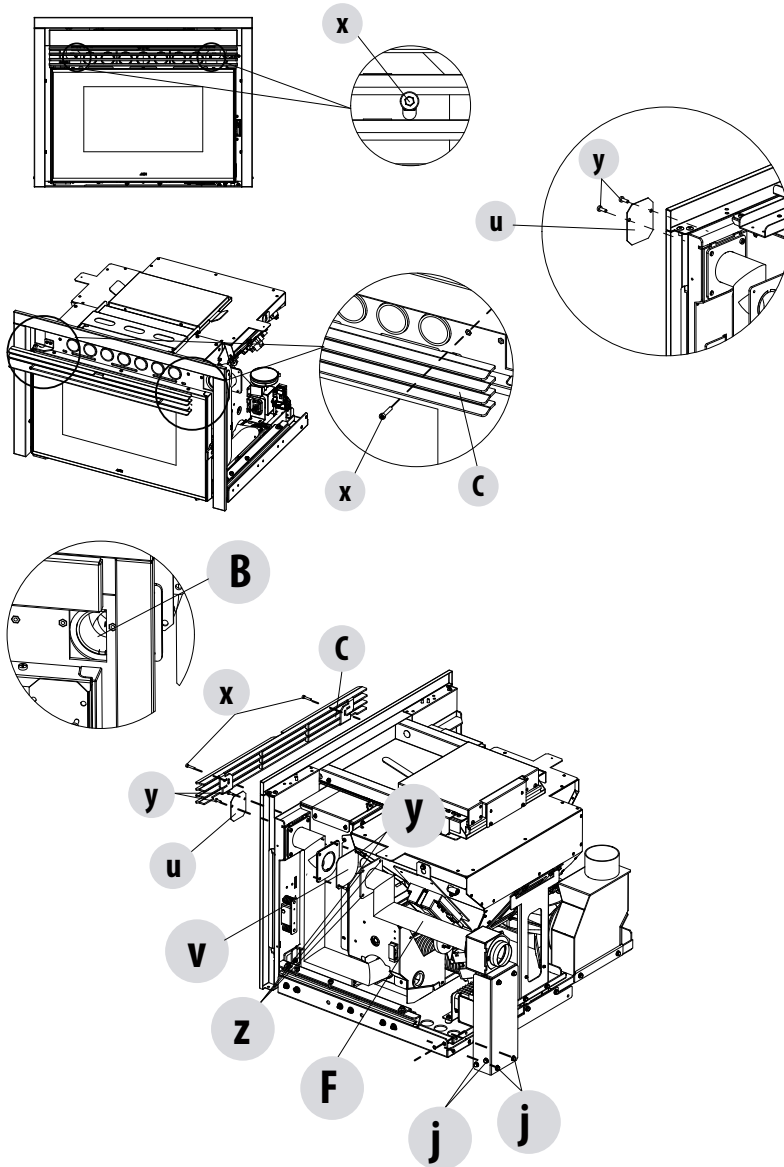

To install the combustion air kit, proceed as follows:

- Unscrew the two screws "x" to remove the front grille "C"

- take the plate "u" from the optional air kit and fasten it to the structure with the two screws "y" so that the front air inlet "B" is closed
- unscrew the two screws "y" to remove the plate "v" from inside
- fasten the combustion air pipe plate "z" to the structure with the two screws "y"
- fasten the air kit "F" to the structure with the 4 screws "j" at the bottom of the back of the structure

10-INSERT EXTRACTION AND LOADING PELLETS IN COLD MACHINE

INSERT EXTRACTION AND LOADING PELLETS

Insert extraction

The insert can be extracted in order to perform routine maintenance (clean the ash pipe at the end of the year) or special maintenance (replacement of electrical parts if the product breaks)

Follow the procedure below to extract the insert:

- open the fire door "C" using the cold handle "Z" supplied
- loosen the nuts "X" so that the plate "M" comes out which stops the insert from being extracted
- to extract the movable part, take hold of the insert by the door or by the inside of the firebox and pull it towards you

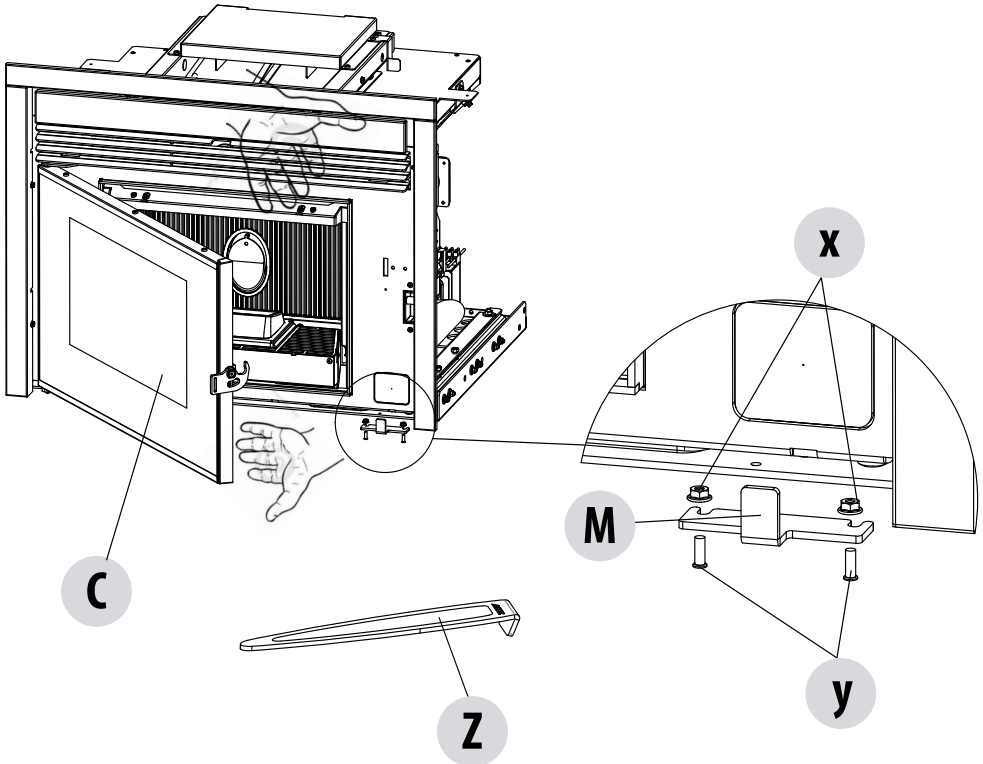

Attention! The insert must only be extracted with the machine off and completely cold.



When loading, do not let the pellet bag come into contact with hot surfaces.

No other type of fuel other than pellets is to be inserted into the hopper, in compliance with above-mentioned specifications. Store the spare fuel at an adequate safe distance.

Do not pour pellets directly onto the brazier but only into the hopper.

When the appliance is running and when it is turned off, most of the stove surfaces are very hot (door, handle, glass, smoke outlet pipes, etc.). Therefore it is recommended to avoid coming into contact with these parts.

The fuel is loaded through the front drawer which is located above the door.

10-INSERT EXTRACTION AND LOADING PELLETS IN COLD MACHINE

PELLET LOADING

- open the drawer "L" using the cold handle "Z" supplied. The guides of the tray have an end-of-travel that block the mobile part when extracted completely.
- Pour the pellets onto the tray either directly from the bag or by using the scoop supplied (A).
- Use the tool (B) supplied to push the pellets towards the hopper.

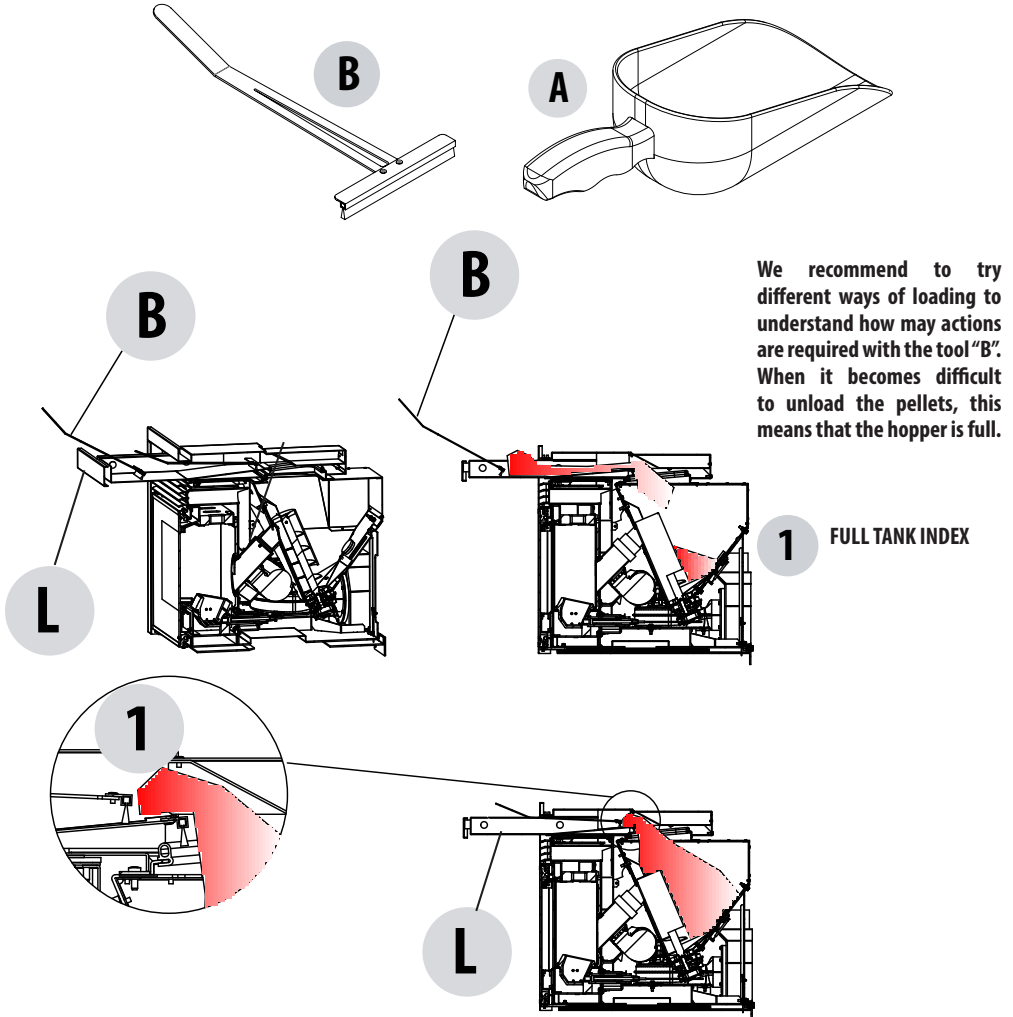

Attention! It is not advisable to load the hot pellets into the product, if this is the case, pay attention to alarm A05. The time required for loading the product is 30 seconds, after which the product enters a pre-alarm stage for another 30 seconds. This stage is indicated by a beeping sound. It is advisable to close the drawer before the 30 seconds have elapsed and then immediately reopen it so as to have an extra 30 seconds. If alarm A05 is triggered, cancel it as instructed on the dedicated page in part 2 of this manual.

11-DOOR OPENING

DOOR OPENING

To open the product door "C", fit the cold handle "Z" into the hole in the handle and pull it towards you.



Attention!

*The firebox door must be closed properly for the stove to work correctly.
The door must only be opened with the product switched off and cold.*

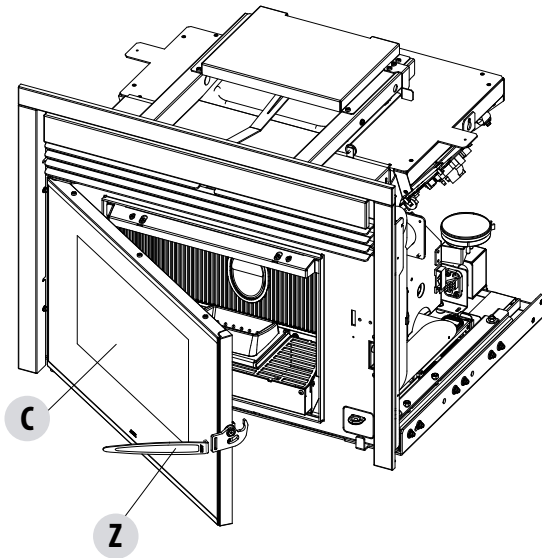

12-ELECTRICAL CONNECTION

ELECTRICAL CONNECTION

First connect the power cable to the rear of the product and then to a **wall socket, which must always remain accessible**. Should this not be possible, during installation insert suitable devices for disconnection from the power mains, in compliance with national electrical installation standards.

It is recommended to disconnect the power cable when the product is not in use.



The cable must never come into contact with the smoke exhaust pipe or any other part of the stove.

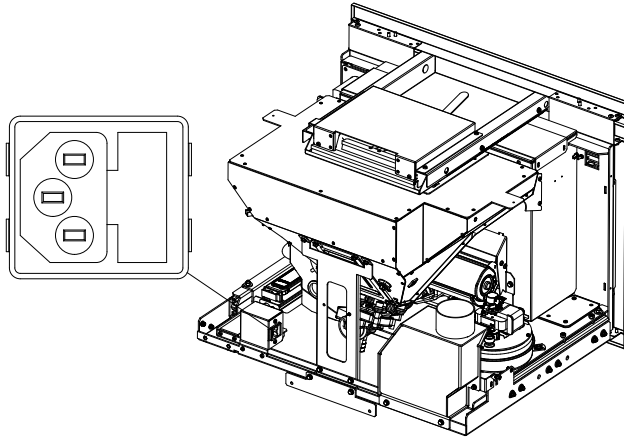

STOVE POWER SUPPLY

Plug the power cable into an electrical socket, the stove is now powered.

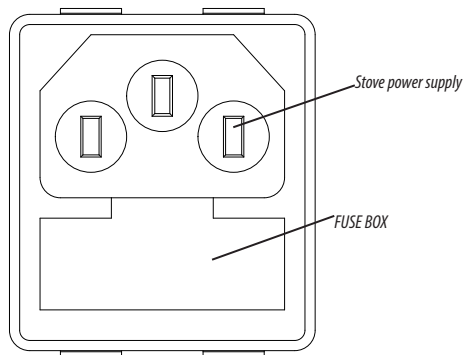

A fuse box is also present in the switch block next to the power socket. Open this compartment by simply lifting the cover, using a screwdriver as a lever from inside the power outlet compartment. Inside there are two fuses (3.15 A delayed), which may need to be replaced if the stove is not powered (e.g. the ON/OFF button does not turn on or the control panel display does not light up)- operation to be implemented by an authorised and skilled technician.

12-ELECTRICAL CONNECTION

ROOM PROBE

The room probe is inside the firebox on the door opening side.

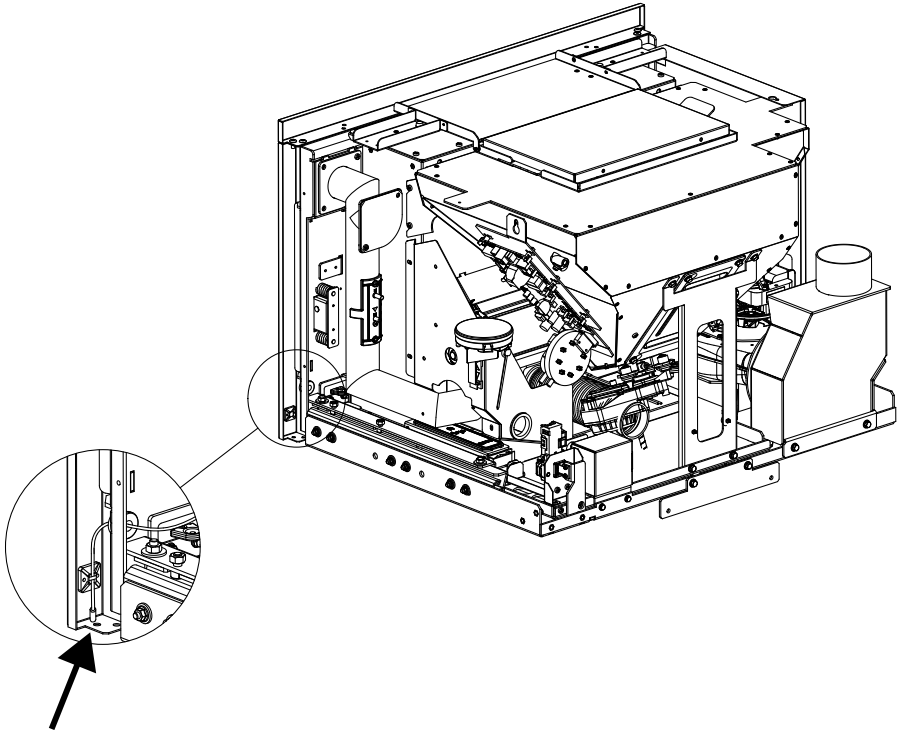

Check that the room probe bulb is near the holes on the frame.

12-ELECTRICAL CONNECTION

CONTROL PANEL

The control panel is supplied with the insert and must be snap fitted in the wall.

When the hole is drilled in the wall "W" for the insert, also drill a 160*45 mm hole "T" for the control panel.

When making the hole for the panel, keep in mind that the connection cable between the panel and circuit board of the insert is 1.4 m and that the circuit board is on the right of the insert (firebox door opening side).

To fix the control panel, proceed as follows:

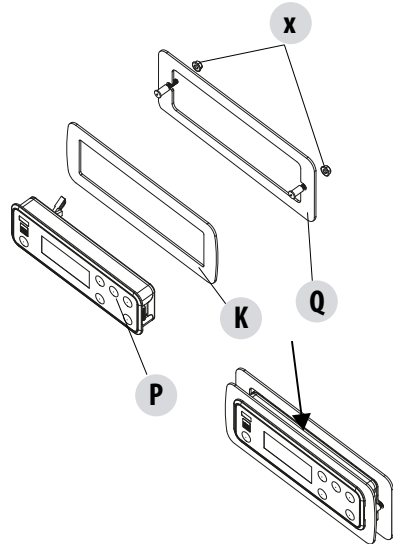
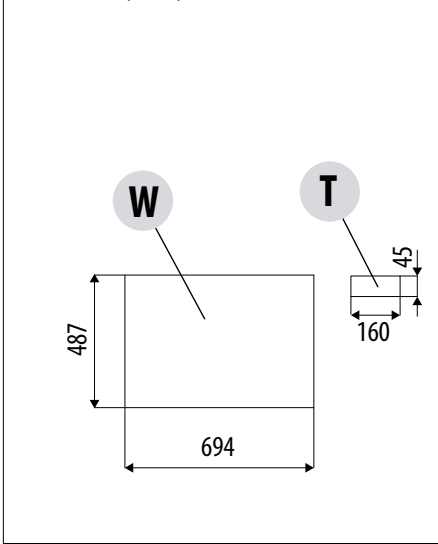

- set the cover plate "K" on the hole previously made
- secure the part "Q" inside using the two nuts "x"
- snap fit the panel "P"

Attention! The wall will be between the piece "Q" and the cover plate "K".

When using the 4-side passe-partout accessory, use the supplied control panel with the insert only with the panel "P".

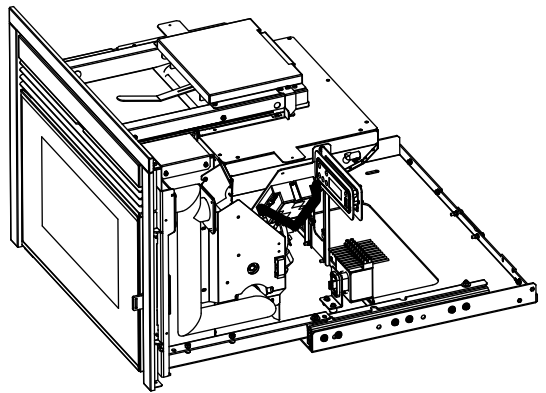
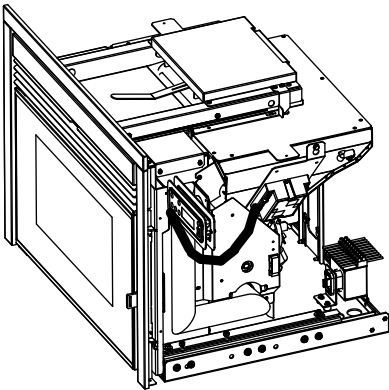

13-CLADDING

SETTING UP THE CLADDING

All product functionalities must be tested before cladding. The company shall not be liable for any damage to the cladding should operating anomalies arise, which were not ascertained before cladding was applied to the product.

IT IS MANDATORY to check the seal of all piping the smoke goes through (smoke fitting, gaskets and insert in the flue) before installing the cladding.

READ THE "OPERATION TEST" CHAPTER BEFORE STARTING ANY PRODUCT CLADDING OPERATION.

The product and parts of the cladding must be fastened to each other **WITHOUT COMING IN CONTACT WITH THE STEEL STRUCTURE** to avoid transmitting heat to the marble and/or stone and to allow for normal thermal dilation; pay attention to wood finishes like beams or shelves.

It is recommended to construct the counter-hood in fire-retardant plasterboard, 15 to 20 mm thick with self-supported galvanized profile frame in order not to bear on the cladding components (wooden beams or marble architraves) which do not have a load bearing structure and **to be able to operate easily in the event of faults and/or future maintenance**. Dry-assemble the hearth of the **cladding leaving a 1 cm gap** between insert and hearth to perform insulation.

WOODEN BEAM INSULATION

If you wish to mount a wooden beam, it must be protected with adequate insulation from hot parts in order to prevent the risk of fire or damage to the cladding.

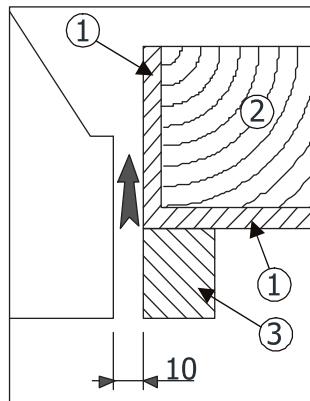

- 1 - INSULATION APPLIED OR TO BE APPLIED
- 2 - WOODEN BEAM
- 3 - MARBLE OR OTHER MATERIAL

13-CLADDING

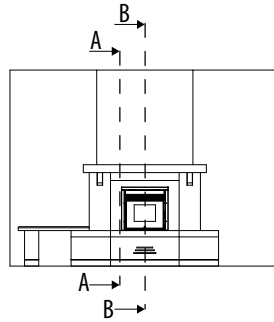
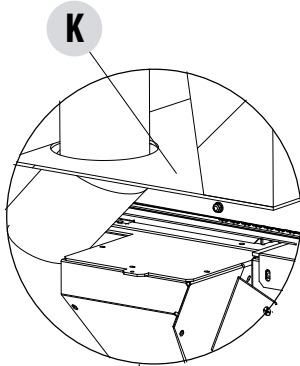

The machine must be insulated (panel K) so as not to receive air from the hood "Z" and counter-hood "Y".

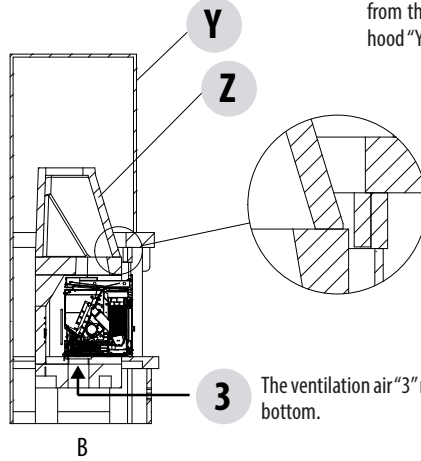
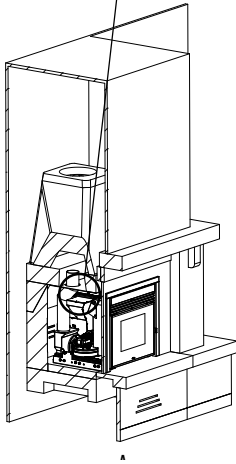

3 The ventilation air "3" must only come from the bottom.

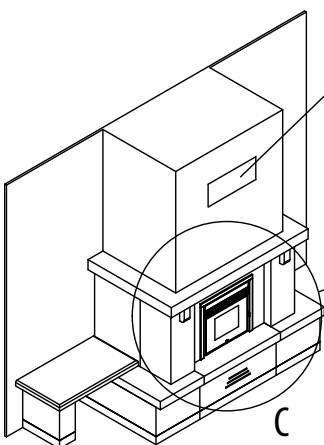

1 - a grille can be used to vent the hot air accumulated at the top of the product

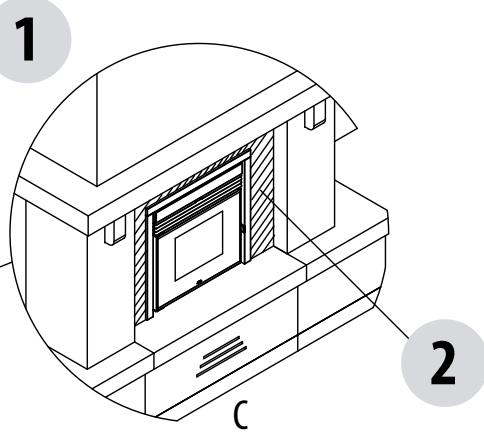

2 - rigid or solid filler panel (not mesh)



MCZ GROUP S.p.A.

Via La Croce n°8

33074 Vigonovo di Fontanafredda (PN) – ITALY

Telephone: 0434/599599 a.s.

Fax: 0434/599598

Internet: www.mcz.it

e-mail: mcz@mcz.it